

Performance Comparison Analysis of Fixed and Solar- Tracker Installed Panel at PV System

by Herdian Wibowo

Submission date: 25-Apr-2023 10:07AM (UTC+0800)

Submission ID: 2074640964

File name: nce_Comparison_Analysis_of_Fixed_and_Solar-Tracker_Installed.pdf (1.97M)

Word count: 4592

Character count: 22831

PAPER • ² OPEN ACCESS

Performance Comparison Analysis of Fixed and Solar-Tracker Installed Panel at PV System

To cite this article: Herdian Wibowo *et al* 2021 *IOP Conf. Ser.: Earth Environ. Sci.* **709** 012003

View the [article online](#) for updates and enhancements.



240th ECS Meeting ORLANDO, FL

Orange County Convention Center Oct 10-14, 2021

Abstract submission due: April 9

SUBMIT NOW

2 Performance Comparison Analysis of Fixed and Solar-Tracker Installed Panel at PV System

Herdian Wibowo¹, Yohandri Bow^{2*}, Carlos R Sitompul³

¹ Applied Master of Renewable Energy Engineering, Politeknik Negeri Sriwijaya, Palembang

² Chemical Engineering Department, Politeknik Negeri Sriwijaya, Palembang

³Electrical Engineering Department, Politeknik Negeri Sriwijaya, Palembang.

*Corresponding Author: yohandriBow@polsri.ac.id

Abstract. Energy generation by conventional energy has been an issue in many countries due to more demands and less supply and getting lesser by the years. This condition urges all the countries in the world to search for other alternatives of energy generation and the desired one is the one with unlimited sources. This unlimited source or self-renewable is called renewable energy. PT. Pertamina (Persero) RU-III Plaju as a state-owned enterprise is committed taking the active role in supporting the government in the campaign of using renewable energy in generating electricity. PT. Pertamina (Persero) RU-III Plaju installed a 3 x 3000 WP PV system to supply the managerial building, and this PV system is considered a research device to develop the possibility of substituting the conventional energy with renewable energy. This paper discussed the performance comparison of the fixed panel and solar-tracking solar panel application for the PV system in PT. Pertamina (Persero) RU-III Plaju. The performance analysis is including final yield, reference yield and performance ratio. Experiment results show that the fixed panel has more energy production with the average percentage of final yield is 3.3% and capacity factor is 13.6%, while the PV panels with solar-tracker have the average final yield of 2.3% and capacity factor of 9.6%. Therefore, this study shows that the application of solar-tracker is not necessary for PV panels in Palembang, due to the average maximal power achieved from 11 AM to 02 PM every day.

1. Introduction

The energy demand in Indonesia is projected to increase by 4.27% per year in 2011-2030 [1, 2]. This energy growth is directly proportional to the increase in population and the rate of economic growth. The depletion of petroleum and coal, which currently are the primary energy resource insist people and government find the alternatives to meet the energy demand. Energy consumption is including electricity generation that relies heavily on fossil fuel, and although Indonesia has a deposit amount of coal of 3.1 billion tons, it will run out in 50 years [3, 4].

The source of energy is divided into non-renewable energy or known as conventional energy and renewable energy. Non-renewable energy is defined as an energy source that cannot be recreated in a short period of time, such as coal, natural gas, and oil. Renewable energy is another type of energy that has unlimited sources, such as hydropower, solar energy, biomass energy, etc.

People started to look for energy alternatives, and one of them comes from above, the sun, which can be the inexhaustible source of energy. The earth only receives the energy emitted by the sun at 69% of the total emission of the sun. The supply of solar energy to the earth reaches 3x10²⁴ joules/year. This energy is equivalent to 2 x 10¹⁷ W. This amount of energy is equivalent to 10,000 times the energy consumption in the entire world today [2, 5]. In other words, only by utilizing 0.1% of the solar energy received on the surface of the earth by using PV system and with the efficiency of



Content from this work may be used under the terms of the [Creative Commons Attribution 3.0 licence](https://creativecommons.org/licenses/by/3.0/). Any further distribution of this work must maintain attribution to the author(s) and the title of the work, journal citation and DOI.

10% alone can cover the needs of the world today. As a tropical country located in the equatorial region, Indonesia has a great potential in developing renewable energy sourced from solar energy of 4.8 kWh/m² per day. The other feature of this type of renewable energy is that it is free of CO₂ emissions and environmental friendly [6].

Solar Power Plant or PV system at PT. Pertamina (Persero) RU-III Plaju is a manifestation of state-owned enterprises campaign for supporting government regulation or Regulation of the Minister of Energy and Mineral Resources (ESDM) No.49 of 2018 in shifting from utilizing fossil fuel into renewable energy, and Regulation of ESDM No. 17 of 2013 regarding State Electricity regulation in purchasing electricity produced by customer's PV system.

PV system based on place of installation is divided into two; roof top and ground installation. PV system is also divided into On-Grid or connected to utility and Off-Grid or stand-alone system. The PV system installed in PT. Pertamina (Persero) RU-III Plaju is an on-grid system used to supply the managerial building with a capacity of 9 kWp and established since 2016 [7].

There are two types of solar panel commonly used; fixed and solar tracker installed panel [6-10]. Fixed panel is the PV system panel that is installed within a certain angle facing the sun. Solar tracker installed panel is made so that the panel can receive sunlight optimally by following the direction of the arrival of sunlight [13-15]. PV system panel with a solar tracker system is expected to produce more power than the fixed panel type. However, in fact, tracker usage on solar panels reduces the electrical energy produced by the panel.

The objective of PV system installation in PT. Pertamina (Persero) RU-III Plaju is a research device in renewable energy in line with government regulation regarding renewable energy for electric generation. Due to this objective, PT. Pertamina (Persero) RU-III Plaju installed both fixed and solar tracker installed PV panel. This paper investigates the performance of both fixed and solar tracker installed PV panel. The performance measurement will be conducted to both types of PV panel installation and compare the result to obtain the optimum generated electricity for the PV system in PT. Pertamina (Persero) RU-III Plaju [16-18]. The result will show the best method to apply in Palembang. The fixed tilt angle is 15°, and solar tracker keeps on rotating based on the detection of the highest intensity of irradiance.

2. Materials and Method

This study is to show the comparison of output power produced by the fixed and solar-tracker installed panel. The research is conducted at the PV system installed in PT. Pertamina (Persero) RU-III Plaju, a state-owned company engaged in energy processing and production. Figure 1 shows the complete installation plan of the fixed and solar-tracker panel considered in this study, and Figure 2 shows the single line diagram of the installed PV system.

Table 1 presents the specification technique of installed PV system, where P_{max} is maximum power, P_{Total} is total power, V_{mp} is voltage at maximum power, I_{mp} is current in maximum power, I_{sc} is current in short circuit, and V_{oc} is the voltage in open circuit.

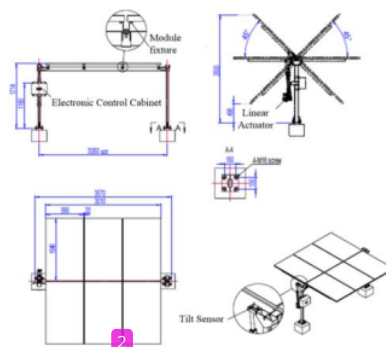

Figure 1. Installation plan of fixed and solar tracker installed PV system

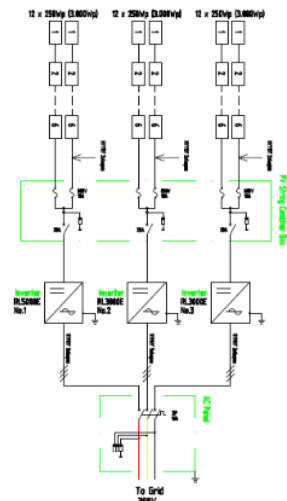

Fig 2. Single line diagram of installed PV System

Table 1. Specification technique of installed PV system

Specification technique	Solar Cell	
	Fixed Mounting	solar Tracker
P_{max}	250 Wp	250 Wp
P_{Total}	3000 Wp	3000 Wp
V_{mp}	30.9 Volt	30.9 Volt
I_{mp}	8.12 Amp	8.12 Amp
I_{sc}	8.47 Amp	8.47 Amp
V_{oc}	37.8 Volt	37.8 Volt
PV cell	36 cell	36 cell
Cell	17.12 %	17.12 %
Efficiency	1640 x 992 x 40 mm	1640 x 992 x 40 mm
Dimension	19.00 kg	19.00 kg
Weight	Monocrystalline	Monocrystalline
Type	Silicon	Silicon

2.1 Solar Power Plant or PV System

PV system is an electric power plant that uses sunlight through the photovoltaic effect to convert solar radiation into electrical energy [19-20]. In simple terms, solar cells consist of a connection between p and n semiconductor materials (p-n junction semiconductor), which is exposed to sunlight, will occur electron flow, and this electron flow is referred to as electric current flow [21]. Figure 3 is the process of converting solar energy into electrical energy.

Many studies have been carried out to develop this renewable energy and give effort in finding the optimum method to harness the energy, one of them is discussing the effect of tilt angle on PV panels [22-27]. The ability of solar power plants to produce electrical energy is very dependent on the intensity of irradiance and duration of the sun's rays exposure on the PV panel [26]. The current technology for a PV system is installing actuators on the panel to direct PV panels to follow the direction of sunlight. This device is called a solar tracker.

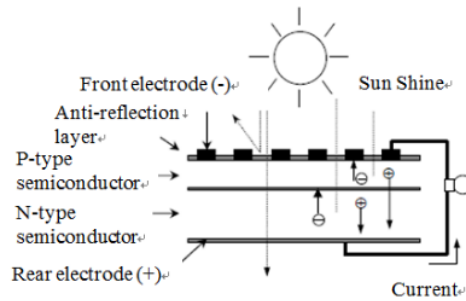

Fig 3. Process of converting solar's ray into electricity

Some research discussing the application of solar tracker for PV system has been simulated and experimentally measured on the produced energy output [27]. The efficiency comparison on single axis sun tracker and dual axis solar tracker was also applied [10][30][6].

2.2 Fixed Panel System

The fixed panel system is solar power plant whose panel installed within certain tilt angle based on the position of the sun or the location of installed PV system relative to the position of the sun during the highest intensity of irradiance of a day. Figure 4 shows the installation of fixed PV panels in PT. Pertamina (Persero) RU-III Plaju. The panels are installed with a 15° tilt angle, and this angle is due to the position of Indonesia. The position of Indonesia is 5° . However, this angle does not have enough cleaning power, therefore, the angle adjusted into 15° to accommodate the possibility of self-cleaning by falling rain that carries dust and dirt on the surface of the PV panel. The solar panels used in PT. Pertamina (Persero) RU-III Plaju are Solar Panel 3000 WP (12 x 250WP) Monocrystalline Type. The number of solar cells per module is 60 cells, with module size (972x1640x40) mm, one solar panel consists of 6 solar modules, with the size of a solar panel (3280x2976x40) mm, and one PV system has two solar panels (3x6 solar modules) with a capacity of 12 x 250WP or 3000WP.



Fig 4. Design of fixed panel system

All three sets of solar generating systems are installed in parallel with a capacity of 3 x 3000WP. The advantage of using the fixed panel system when compared to the sun tracker system is that the installation price is relatively cheaper because it does not require an actuator to drive the PV panel, but it is not optimal in receiving sunlight because it cannot follow the direction of the light.

2.3 Solar Tracker System

Fig 4 and 5 show the design of the solar tracker system. solar tracker system is a further development of finding the best way to harvest solar energy and convert it into electrical energy. This system is designed to overcome the problems found in fixed panel systems, which are less optimal reception of sunlight by PV panels; therefore, it does not produce optimum electrical energy. The solar tracker system has an actuator that can move the PV panel in accordance with the direction of sunlight, and solar sensor to sense the direction of the sun. The PV system in PT. Pertamina (Persero) RU-III Plaju has a solar Panel 3000 WP (12 x 250WP) with Monocrystalline type. The number of solar cells per module is 60 cells, with module size (972x1640x40) mm. One solar panel consists of 6 solar modules,

with the size of a solar panel (3280x2976x40) mm. One system has two solar panels (2x6 solar modules) with a capacity of 12 x 250WP or 3000WP. All three sets of solar generating systems are installed in parallel with a capacity of 3 x 3000WP.

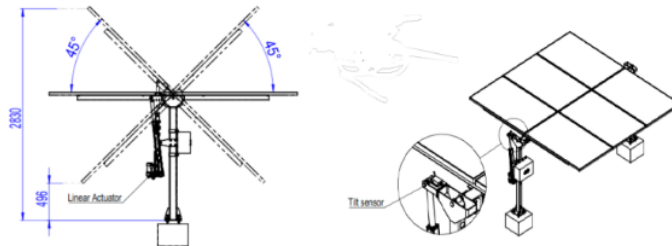

Fig 5. Design of Solar Tracker System

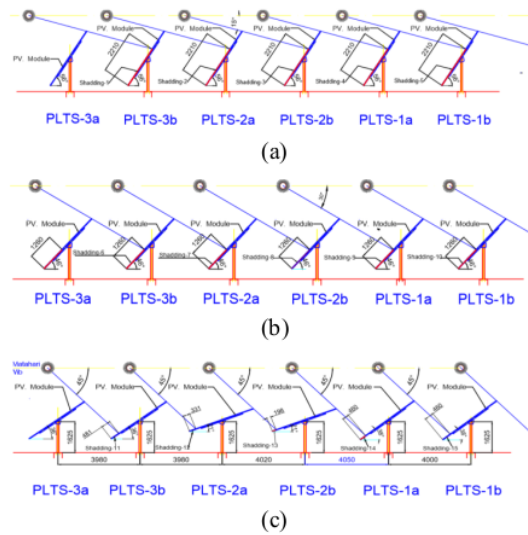

Fig 6. PV panel position at (a) 07.00 AM, (b) 08.00 AM and (c) 09.00 AM.



(a) Solar tracker sensor



(b) Installed solar tracker and actuator in PV system

Fig 7. Solar trackern and the nstalled solar tracker with actuator in PV system

Fig 7 shows the solar tracker sensor and the installed solar tracker along with the actuator used to move the panel.

2.4 Performance Analysis of PV System

Based on IEC 61724: Photovoltaic system performance monitoring-guidelines for measurement, data exchange and analysis, and performance parameter of the PV system is represented by [21]:

2.4.1 Final Yield

Final yield (YF) is set in the annual, month, or daily period of the AC energy output on the system divided by the peak power of the PV array installed at standard test conditions (STC) on solar irradiation 1000W/m^2 and cell temperature 25°C .

$$Y_F = \frac{E_{PV}}{P_O} \dots (1)$$

where

EPV = power given to network (kWhAC)

PO = peak power (kWpDC)

2.4.2 Reference Yield

The Reference Yield (YR) is the total of the insulation in a field divided by the iridation array installed under standard test conditions (STC).

$$Y_R = \frac{H_T}{G_{STC}} \dots (2)$$

where

HT = irradiance falls on array (kWh/m²)

GSTC = irradiance reference STC (1kW/m²)

2.4.3 Performance Ratio

The Performance Ratio (PR) can determine the quality of a PV system. PR is expressed as a percentage, this percentage shows the total ratio of the system when converting from DC to AC output.

$$PR = \frac{Y_F}{Y_R} \dots (3)$$

where

PR = performance ratio (%)

2.4.4 Capacity factor

The capacity factor of a PV system is also expressed as a percentage. The capacity factor is the final result of YF in a three-month period with output if it operates at nominal power for three months.

$$CF = \frac{Y_F}{1464} \dots (4)$$

where

CF = capacity factor (%)

3. Results and Discussion

The installed PV system in PT. Pertamina (Persero) RU-III Plaju solar power plants is monitored via Ethernet as shown in Figure 8. Electric power output data from the PV system can be read via Ethernet. However, in the research, direct measurements were carried out for several parameters. The solar tracker consider in this study is single axis solar tracking at PT Pertamina (Persero) RU 3 Plaju as shown in Figure 9.

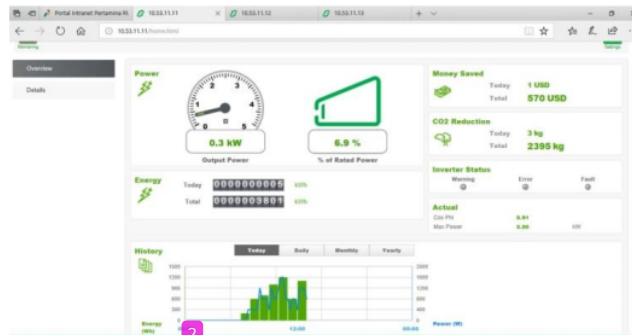

Fig 8. The monitoring of PV system in PT. Pertamina (Persero) RU-III Plaju



Fig 9. PV system installed at PT Pertamina (Persero) RU 3 Plaju**3.1 Data Output PV System in PT. Pertamina (Persero) RU III Plaju**

PV system installed at PT. Pertamina (Persero) RU III Plaju uses modules with materials made of monocrystalline. The solar panel consists of 12 modules with each producing power of 250 Wp, or 3000 WP per PV system. Overall, three sets of solar generating systems are installed in parallel with a capacity of 3 x 3000WP. Table 2 is the PV system produced power within 3 months.

Table 2. Data produced within 3 months

Date	Output Power (kWh)	Rate of Irradiance/day (w/m ²)
May 29 – Jun 17, 2017	150.1	4,620.99
Jun 18 – Jul 7, 2017	133.4	4,595.10
Jul 8 – Jul 27, 2017	132.2	4,636.35
Jul 29 – Aug 17, 2017	188.1	5,966.54
Aug 18 – Sep 6, 2017	190.3	5,882.30
Sep 7 – Sep 26, 2017	210.3	6,387.30

Fig 10 shows the power output comparison between fixed and solar tracker installed panel. Based on data in table 2 and Figure 10, fixed panel produces more power than solar tracker installed panel.

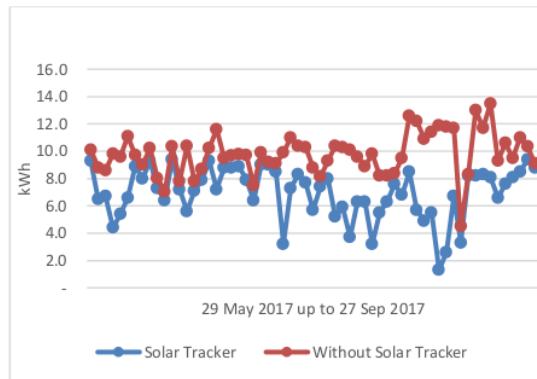
**Fig 10.** The power output comparison between fixed and solar tracker installed panel

This condition is due to the use of PV system with a solar tracker system that has a one-axis drive actuator that moves the PV panel to follow the direction of sunlight direction. This actuator consume electricity as its source, and the electricity consumed comes from solar panels that are driven by actuators which causes a reduction in the energy produced by the solar panel. In the end when compared to fixed panel systems, PV system with a solar tracker system is less efficient to use as a power plant at PT. Pertamina (Persero) RU-III Plaju.

3.2 Performance Analysis of PV System installed in PT. Pertamina (Persero) RU-III Plaju

From the data results of electricity production output comparison in PV system with a fixed and solar tracker installed panel during the period of May 29, 2017 to September 26, 2017, it can be seen that electricity production in PV system PT. Pertamina (Persero) RU-III Plaju with an average fixed panel system is 9.8 kWh, this value is greater than PV system with a solar tracker system where the average production of electricity produced is only 7.0 kWh. Table 2 shows the specific performance and factors of the PV system capacity of PT. Pertamina (Persero) RU-III Plaju. By using two solar panels installed in a Solar tracker system and a fixed panel system PT. Pertamina (Persero) RU-III Plaju

produces 1,022 MWh of electricity for three months, with a performance ratio (PR) of 51.9% with production details can be seen in Table 2.

Table 3. Specific performance and capacity factor of PV system in PT. Pertamina (Persero) RU-III Plaju

Date	Output Power (kWh)	YF (%)	CF (%)	YR (%)	PR (%)
May 29 – Jun 17, 2017	150.1	2.5	10.4	4.6	54.1
Jun 18 – Jul 7, 2017	133.4	2.2	9.3	4.6	48.4
Jul 8 – Jul 27, 2017	132.2	2.2	9.2	4.6	47.5
Jul 29 – Aug 17, 2017	188.1	3.1	13.1	6.0	52.5
Aug 18 – Sep 6, 2017	190.3	3.2	13.2	5.9	53.9
Sep 7 – Sep 26, 2017	210.3	3.5	14.6	6.4	54.9

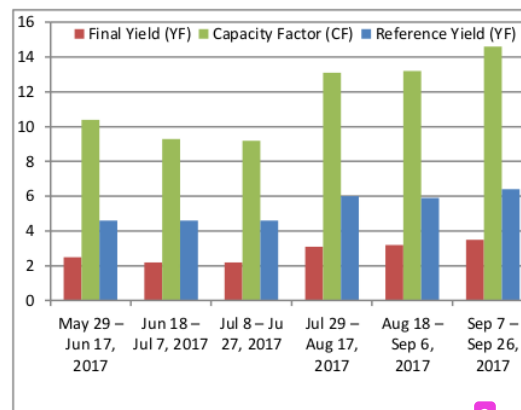

Figure 11. Specific performance and capacity factor of PV system in PT. Pertamina (Persero) RU-III Plaju

The data in Table 3 shows that there is an increase in specific performance and capacity factors in PV system PT. Pertamina (Persero) RU-III Plaju. Figure 11 shows the comparison of specific performance and capacity factor of PV system in PT. Pertamina (Persero) RU-III Plaju. The increase occurred when implementing the fixed panel system in PV system starting on 29 July - 27 September 2017. The final yield or the final result of PLTS with a fixed panel system on 29 July - 27 September 2017 the average percentage is 3.3%. This result is greater than the PV system with solar tracker system where the average percentage of final results (YF) is 2.3% in vulnerable time 29 May - 28 July 2017. Figure 11 shows the specific performance and PV system capacity factors of PT. Pertamina (Persero) RU-III Plaju for three months.

4. Conclusion

Experiment results shows that the characteristics of changes in output power data that are not affected by tracker or static usage. Output power data shows the setup of solar panels with solar tracker, does

not increase the output of electrical power produced compared to fixed panel. This is because, among other things: the use of an actuator reduces the output of electrical energy for external loads. Solar tracker does not increase the efficiency of solar panel electrical power output. Specific performance and capacity factor in PLTS with fixed panel system average percentage yield (YF) is 3.23% and the average percentage capacity factor (CF) is 13.6% which is greater than PV system with a solar tracker system that only has an average. The final yield percentage (YF) is 2.37% and the average capacity factor (CF) percentage is 9.6%.

References

- [1] Sugiyono A, Permana A, Boedoyo S, and Adiars. 2013. Outlook Energi Indonesia 2013.
- [2] Dewi T, Risma P, Oktarina Y, Roseno M T, Yudha H M, Handayani AS and Wijanarko Y 2016 A Survey on Solar Cell; The Role of Solar Cell in Robotics and Robotics Application in Solar Cell Industry *Proc Forum in Research, Science, and Technology FIRST* C19-C22
- [3] Yudha H. M., Dewi T, Risma P and Oktarina Y 2018 Life Cycle Analysis for the Feasibility of Photovoltaic System Application in Indonesia *presented at the IOP Conference Series: Earth and Environmental Science* **124** 012005
- [4] P. E. Nasional. 2005 Blueprint Pengelolaan Energi Nasional 2005–2025.
- [5] Putra I. M, Rosma I. H. 2018. Design and Analysis of Single Axis Sun Tracker Systems to Increase Photovoltaic Solar Power Output. *JOMFTEKNIK*. **5** pp. 1–5.
- [6] R Ploetz, R, Rusdianasari, E Eviliana, “Renewable Energy Advantages and Disadvantages”, *Proceeding Forum in Research, Science and Technology (FIRST)*, 2016.
- [7] N. Zhafarina, T. Dewi, R. Rusdianasari, “Analysis of Maximum Power Reduction Efficiency of Photovoltaic System at PT. Pertamina (Persero) RU III Plaju”, *Volt*, Vol. **3**, No. 1, 2018.
- [8] Bazaryi S, Keypour R, Farhangi S, Ghaedi A, and Bazaryi K. 2014. A Study on the Effects of Solar Tracking Systems on the Performance of Photovoltaic Power Plants. *Journal of Power and Energy Engineering*. **2**(4) pp. 718–728.
- [9] Bilal M, Arbab M. N, Afridi M. Z. U. A, and Khattak A. 2016. Increasing the Output Power and Efficiency of Solar Panel by Using Concentrator Photovoltaics (CPV). *International Journal of Engineering Works*. **3**(12) pp. 98–102.
- [10] Musa Y and Kentli F. 2015. Increasing of Electrical Energy with Solar Tracking System at the Region which Has Turkey’s Most Solar Energy Potential. *Journal of Clean Energy Technologies*. **3**(4) pp. 10–13.
- [11] Amadi H. N and Gutierrez S. 2019. Design and Performance Evaluation of a Dual-Axis Solar Tracking System for Rural Applications. *European Journal of Electrical & Computer Engineering*. **3**(1) pp. 1–6.
- [12] Dhanabal R, Bharathi V, Ranjitha R, Ponni A, Deepthi S, and Mageshkannan P. 2013. Comparison of Efficiencies of Single-Axis Tracking System and Dual-Axis Tracking System with Fixed Mount. *International Journal of Engineering and Technology*. **5**(2) pp. 1926–1933.
- [13] Banerjee R. 2015. Solar Tracking System. *International Journal of Scientific and Research Publications*. **5**(3) pp. 1–7.
- [14] Logan P. E, Hall K. H, and Raichle B. W. 2014. Performance Comparison Of Fixed , Single , And Dual Axis Tracking Systems For Small Photovoltaic Systems With Measured Direct Beam Fraction. pp. 1–5.
- [15] Ozcelik S, Prakash H, and Chaloo R. 2011. Two-Axis Solar Tracker Analysis and Control for Maximum Power Generation. *Procedia Computer Science*. **6** pp. 457–462.
- [16] Dewi T, Risma P, Oktarina Y. 2019. A Review of Factors Affecting the Efficiency and Output of a PV System Applied in Tropical Climate *presented at the IOP Conference Series: Earth and Environmental Science*. **258** 012039. doi: 10.1088/1755-1315/258/1/012039
- [17] Harahap H. A., Dewi T., and Rusdianasari. 2019. Automatic Cooling System for Efficiency and Output Enhancement of a PV System Application in Palembang, Indonesia. *J. Phys: Conf. Ser.* **1167** 012027 <https://doi.org/10.1088/1742-6596/1167/1/012027>
- [18] Setiawan F, Dewi T. and Yusi S. 2019. Sea Salt Deposition Effect on Output and Efficiency

- Losses of the Photovoltaic System; a case study in Palembang, Indonesia. *J. Phys: Conf. Ser.* **1167** 012028 <https://doi.org/10.1088/1742-6596/1167/1/012028>
- [19] Axaopoulos P. J, and Fylladitakis E. D. 2013. Energy And Economic Comparative Study Of A Tracking Vs A Fixed Photovoltaic System. *European Scientific Journal.* **6**(12) pp. 50–69.
- [20] Hammad B, Ali S, Al-abed M, and Nijmeh S. 2017. Performance and economic comparison of fixed and tracking photovoltaic systems in Jordan. *Renewable and Sustainable Energy Reviews.* **80** pp. 827–839.
- [21] Simamora A. M. 2015. Utilization Of Solar Cell As An Energy Source In The Water Wall System. **4**(2) pp. 183–189.
- [22] Talebizadeha P, Mehrabiana M. A, and Abdolzadehb M. 2011. Determination of Optimum Slope Angles of Solar Collectors Based on New Correlations. *Energy Sources.* **33**(17) pp. 1567–1580.
- [23] Jawhar S. and Shareef M. 2017. The Impact of Tilt Angle on Photovoltaic Panel Output. *Journal of Pure and Applied Sciences.* **29**(5) pp. 112–118.
- [24] Chandrakar A and Tiwari Y. 2013. Optimization of Solar Power by varying Tilt Angle / Slope. *International Journal of Emerging Technology and Advanced Engineering.* **3**(4) pp. 145–150.
- [25] Markam K, Sudhakar K, Centre E, and Bhopal M. 2016. Estimation of optimal tilt angle for solar photovoltaic installations in India. *International Research Journal of Engineering and Technology.* **3**(5) pp. 2735–2741.
- [26] Kurniawan. A., Taqwa A., and Bow Y. 2019. PLC Application as an Automatic Transfer Switch for on-grid PV System: Case Study Jakabaring Solar Power Plant Palembang. *J. Phys: Conf. Ser.* **1167** 012026 <https://doi.org/10.1088/1742-6596/1167/1/012026>
- [27] Y. Bow, T. Dewi, A. Taqwa, Rusdianasari and Zulkarnain, "Power Transistor 2N3055 as a Solar Cell Device," *2018 International Conference on Electrical Engineering and Computer Science (ICECOS)*, Pangkal Pinang, 2018, pp. 327-332. doi: 10.1109/ICECOS.2018.8605203
- [28] S. Ch. 2010. Perbandingan Unjuk Kerja Antara Panel Sel Surya Berpenjejak. *Teknologi Elektro.* **9**(1) pp 6–11.
- [29] Perraki V. 2014. Single Axis Tracker Versus Fixed Tilt Pv: Experimental And Simulated Results. *29th EU PhotovoltaicSolar Energy Conference.* pp. 2711–2714.
- [30] Heslop S and Iain S. 2014. Comparative analysis of the variability of fixed and tracking photovoltaic systems. *Solar Energy.* **107** pp. 351–364.

Performance Comparison Analysis of Fixed and Solar- Tracker Installed Panel at PV System

ORIGINALITY REPORT

18%

SIMILARITY INDEX

18%

INTERNET SOURCES

12%

PUBLICATIONS

7%

STUDENT PAPERS

PRIMARY SOURCES

1	Submitted to Universitas Andalas Student Paper	7%
2	iopscience.iop.org Internet Source	5%
3	mail.ijaers.com Internet Source	3%
4	www.researchgate.net Internet Source	3%

Exclude quotes On

Exclude bibliography On

Exclude matches < 3%