



# 2<sup>nd</sup> FIRST 2018

**Forum in Research, Science, and Technology**  
*Applied Technology for Sustainable Development  
in Supporting Prosperous Human Existence*

**October 30-31, 2018**

Horison Ultima Hotel  
Palembang, Indonesia

**CONFERENCE  
PROCEEDING**

ISSN: 2461-0739

Published By:  
Research and Community Service Center State Polytechnic of Sriwijaya  
Jl. Srijaya Negara Bukit Besar 30139 Palembang  
Sumatera Selatan, Indonesia

# **The 2nd Forum in Research, Science, and Technology FIRST 2018 INTERNATIONAL CONFERENCE**



**(The 2nd FIRST 2018)**

**OCTOBER 30-31, 2018 — PALEMBANG, OF SOUTH SUMATERA INDONESIA**

**Conference Programs And Abstract from the 2nd FIRST 2018**

Edited by

**Polytechnic Of Sriwijaya  
Palembang Of South Sumatera Indonesia  
2018**



## ORGANIZING COMMITTEE

### International Advisory Committee

- Prof. Erry Yulian Triblas Adesta, International Islamic University, Malaysia
- Prof. Dr. Rahmat Budiarto, Al Baha University, Saudi Arabia Assoc
- Prof. Dr. Augustus E. Osseo-Asare University of Sunderland, United Kingdom
- Prof. Dr. Werner Rammense, Cologne University, Germany
- Prof. Badri Munir Sukoco, SE.,MBA.,Ph.D, Universitas Airlangga Indonesia

### Steering Committee

- Prof. Muhammad Nizam, Ph.D, Universitas Sebelas Maret, Indonesia
- Prof. Dr. Mohammad Yeakub Ali, International Islamic University Malaysia Assoc.
- Prof. Ahmad Hoirul Basori, King Abdulaziz University, Saudi Arabia
- Mohammad Hossein Anisi, University of Essex, UK
- Dr. Zulhadi Zakaria, Politeknik Seberang Perai, Malaysia
- Dr. Ing. Ahmad Taqwa, M.T, Politeknik Negeri Sriwijaya, Indonesia
- Prof. Dr. Ir. Siti Nurmaini, Universitas Sriwijaya, Indonesia
- Prof. Assoc. Pindo Tutuko, Ph.D University of Merdeka, Malang, Indonesia
- Dr. Dodik Siswanto S.E., M.Sc. Acc, Universitas Indonesia
- Dr. Irwan Meilano ST,M.Sc, ITB, Indonesia
- Dr. Gancar Candra Premananto, SE., M.Si., Universitas Airlangga
- Munawar A. Riyadi, Universitas Diponegoro, Semarang, Indonesia
- Ir. Amrifan Saladin Mohruni Ph.D, Universitas Sriwijaya, Indonesia
- Dr. RD. Kusumanto, MM, Politeknik Negeri Sriwijaya, Indonesia
- Dr. H. Nandan Limakrisna, Ir., M.M., CQM, Universitas Persada Indonesia
- Irsyadi Yani, ST., M.Eng. PhD, Universitas Sriwijaya, Indonesia
- Dr. Yohandri Bow, MT, Politeknik Negeri Sriwijaya, Indonesia
- Dr. Yuli Yetri, M.Si, Politeknik Negeri Padang
- Dr. Eng. Tresna Dewi, M.Eng., Politeknik Negeri Sriwijaya, Indonesia
- Dr. Maya Fitri Oktarini S.T., M.T., Universitas Sriwijaya, Indonesia
- Ir. Indra Chandra Setiawan, M.T., PT. Toyota Motor Manufacturing, Indonesia

### General Chair

Dr.Ir.Rusdianasari, M.Si, Politeknik Negeri Sriwijaya, Indonesia

**General co-Chairs**

- Carlos R. Sitompul, S.T.,M.T., Politeknik Negeri Sriwijaya, Indonesia
- Ir. Jaksen M. Amin, M.Si, Politeknik Negeri Sriwijaya, Indonesia
- Dr. Rita Martini, SE.,M.Si.,Ak.,CA, Politeknik Negeri Sriwijaya, Indonesia

**Publication Chairs**

- Deris Stiawan, M,Kom, PhD., Universitas Sriwijaya, Indonesia
- Desloehal Djumrianti, S.E., MIS., PhD, Politeknik Negeri Sriwijaya, Indonesia
- Ade Silvia Handayani, S.T., M.T, Politeknik Negeri Sriwijaya, Indonesia

**Technical Program Chairs**

- Muhammad Abu Bakar Sidik, S.T., M.Eng., Ph.D, Universitas Sriwijaya, Indonesia
- Reza Firsandaya Malik, S.T., M.T., Ph.D, Universitas Sriwijaya, Indonesia
- Nyayu Latifah, S.T., M.T, Politeknik Negeri Sriwijaya, Indonesia
- Dr. Herlambang Saputra, S.Pd., M.Kom., Politeknik Negeri Sriwijaya, Indonesia

**Finance Chairs & Treasurer**

Dr. Marieska Lupikawati, S.E., M.M, Politeknik Negeri Sriwijaya, Indonesia

**Public Relation Chairs**

- Ir. Irawan Rusnadi, M.T. , Politeknik Negeri Sriwijaya, Indonesia
- Drs Zakaria MPd., Politeknik Negeri Sriwijaya, Indonesia
- Dra. Tiur Simanjuntak, M.Ed.M, Politeknik Negeri Sriwijaya, Indonesia
- Sukandar S.Si.,M.T,Ph.D., Institut Teknologi Bandung, Indonesia
- Dr. GK Marriappen, Politeknik Seberang Perai, Malaysia
- Dr. Sari Lestari Zainal Ridho, SE., M.Ec, Politeknik Negeri Sriwijaya, Indonesia
- Dr. Lambok Vera R Pangaribuan, S.E., M.Si, Ak, Politeknik Negeri Sriwijaya, Indonesia
- Dr. Ir.Leila Kalsum, M.T, Politeknik Negeri Sriwijaya, Indonesia
- Dr. Martha Aznury, M.Si., Politeknik Negeri Sriwijaya, Indonesia
- Dr. Ir. Abu Hasan, M.Si., Politeknik Negeri Sriwijaya, Indonesia
- Dr. Leily Nurul Komariah, S.T., M.T., Universitas Sriwijaya, Indonesia
- Anton Satria Prabuwono, King Abdulaziz University
- Irfan Syamsuddin, Politeknik Negeri Ujung Pandang, Indonesia

- Ahmad Hoirul Basori, King Abdulaziz University, Saudi Arabia
- Ermatita, Universitas Sriwijaya, Indonesia
- Irfan Syamsuddin, Politeknik Negeri Ujung Pandang, Indonesia
- Muhammad Syafrullah, Universitas Budi Luhur, Jakarta, Indonesia
- Anton Yudhana, Universitas Ahmad Dahlan, Yogyakarta, Indonesia
- Zulfatman, Universitas Muhammadiyah Malang, Malang, Indonesia
- Mochammad Facta, Universitas Diponegoro, Semarang, Indonesia
- Imam Much Ibnu Subroto, Universitas Islam Sultan Agung, Semarang, Indonesia
- Uuf Brajawidagda, Politeknik Negeri Batam, Indonesia
- Firdaus, S.T., M.Kom., Universitas Sriwijaya, Indonesia
- Syarifah Putri Raflessia. S.Kom. M.T., Universitas Sriwijaya, Indonesia

### **Local Chairs**

- Firdaus, S.T., M.T., Politeknik Negeri Sriwijaya, Indonesia
- Aladin SE, M.Si., Ak, CA, Politeknik Negeri Sriwijaya, Indonesia
- M. Miftahul Amin, S.Kom., M.Eng., Politeknik Negeri Sriwijaya, Indonesia
- Dr. Evada Dewata, S.E., M.Si., Ak, CA, Politeknik Negeri Sriwijaya, Indonesia
- Dr. M. Syahirman Yus S.E., M.S., Politeknik Negeri Sriwijaya, Indonesia
- Dr. Ir. Aida Syarif, M.T., Politeknik Negeri Sriwijaya, Indonesia
- Dr. Neneng Miskiyah, S.E. M.Si., Politeknik Negeri Sriwijaya, Indonesia
- Dr. Periansya, M.M., Politeknik Negeri Sriwijaya, Indonesia
- Dr. Markoni Badri, S.E., MBA, Politeknik Negeri Sriwijaya, Indonesia
- Dr. Heri Setiawan, M.M., Politeknik Negeri Sriwijaya, Indonesia
- Ikhtison Mekongga, S.T., M.Kom., Politeknik Negeri Sriwijaya, Indonesia
- Yudi Wijarnako, S.T., M.T., Politeknik Negeri Sriwijaya, Indonesia
- Pridson Mandiangan, S.E., M.M., Politeknik Negeri Sriwijaya, Indonesia
- Adewasti, S.T., M.Kom., Politeknik Negeri Sriwijaya, Indonesia
- Hairul, S.T., M.T., Politeknik Negeri Sriwijaya, Indonesia
- Eka Susanti, S.T., M.Kom., Politeknik Negeri Sriwijaya, Indonesia
- Leni Novianti, M.Kom., Politeknik Negeri Sriwijaya, Indonesia

# Design of Automatic Rice Seeder in Laboratory Scale

A A Sani<sup>1,2</sup>, Iskandar<sup>1</sup>, D Seprianto<sup>1</sup>, R Wilza<sup>1</sup>, and Roby Pradiga<sup>1</sup>

<sup>1</sup>Mechanical Engineering Department, Politeknik Negeri Sriwijaya, Indonesia

<sup>2</sup>E-mail:almadora@polsri.ac.id

**Abstract.** Automatic seeder based android in laboratory scale aims to helping the farmers in the seeding process before planting in field. This machine also automatically treats the seeds regularly by ordering the program through android to simplify the use of the tool. So ease farmers in terms of energy and time spent. This tool has an electric motor using a microcontroller. System as a driver with the help of android that will run the program. The seeding process is carried out in 2 stages: first spreading the rice seeds and second watering the rice seeds, then regularly will take care of the rice seeds to develop. The process of designing machine applying CAD software while for fabrication use of drilling machine soldering machine, 3D printing and hand tools. After making the prototype of this tool is tested in laboratory and the result of this tool can spread rice seeds as much as 12 grams with time of 1 second.

## 1. Introduction

Seeding is part of internal preparation process of planting rice. Preparation of planting rice in the rice field is a strategic effort in order to support the increased production of rice seeds. Rice seeding's contribution to increased rice production can be reflected from the savings in time, effort and achievement of quality rice seeds in accordance with quality requirements.

Farmers in Indonesia are still in the process of seeding the rice seeds are traditionally. If done with this system activity will cause wastage of seeding seeds, water, a relatively long time, energy was quite laborious and still a lack of awareness and understanding of the farmers against planting rice preparation is good.

To reduce the risk that would be detrimental to farmers, then designed innovation tools seeding rice seeds automatically scale laboratory. Resulting in a prototype tool that can be further developed to help farmers in the process of breeding is ultimately expected to boost the production of rice seeds and agricultural welfare as well as plantations. This tool aims to reduce human labor for rice seeds in the process manually. The process of seeding the rice seeds in manual still takes quite a long time for the one-time process of seeding.

## 2. Literature review

Seeding is a process of preparation of the new plant seedlings planted on land before. Rice seed sown at a place in advance until a certain age recently moved into paddy fields. Seeding is very important, especially on rice seed is not smooth and resistant to external factors that could hamper the growth of the seed into the rice seeds. The purpose of seeding seeds is to prepare the rice seeds which have good quality so that it can eventually grow up to be a good rice anyway. In addition this way will be more effective and



efficient in the use of land for nursery and also avoid the occurrence of the failure of the nursery because we can perform observations on the development of seed to a certain age [1].



**Figure 1.** Wet seeding

Seeding techniques of rice dry system is a new way of sowing the seeds of rice. Seeding can be done on the home page. The advantage of this technique is easy to do, practically in the harvesting of the seeds (only rolled only), easy maintenance, the cost of labor is cheaper, and more controlled because of seedlings near the residence.



**Figure 2.** Dry seeding.

Land used for rice in the media tray/dapog is a fertile soil is derived from the yard free of the piles of trash or ground rice. The land drained to dry very well the next mash until soft then filtered with a filter wire size 0.5 cm, then the soil mixed with organic fertilizer comparison with 4:1 (3 liters of soil/tray) consists of 2.25 liter ground 0.75 liter organic manure or Nitrogen 1gr/tray, Phosphate, 1 gr/1 gr of potassium, tray/tray, then stirred [2]. Rice planting is very old method from many years ago & having long history since many years & their methods of rice planting are changed in this decade. Use of rice Trans planter machines is new trend but current machines having high cost of purchase. So the main focus of this project is to minimize the cost of that machine [3]. The total thickness of the material for all rice seedlings was 2.97 cm from the target thickness of 3 cm or 99% accuracy. The average capacity of

seeding with this machine is 10 seconds / tray or 6 trays / minute with an average power requirement of 247.5 watts of operation [4].

Thousands of crosses designed to produce cultivars with high yield potential and resistance to various pests and diseases of rice. In 1984 the Government of Indonesia has ever received from the United Nations (FAO) due to successful rice production to increase in the next 20 years can change from the world's largest rice importer into the country's self-sufficiency in rice. These achievements cannot be continued and recently recovered since the year 2007 [5]. It has designed rice seed tape twisting machine in this paper. The machine consists of non-woven feeding mechanism, binder brushing mechanism, seed sowing mechanism, fertilizer sowing mechanism, materials locating mechanism, twisting mechanism, drying mechanism, seed tape disk winding mechanism, seed tape fracture testing mechanism and so on. The machine can drop seeds and fertilizers on the spun bonded non-woven fabric made of polylactide (PLA) and made into seed tape disk [6].

In this design, the rice to be de-stoned is fed into the separation chamber through the hopper which is fixed at an elevation higher than the rest of the separation bed. The combination of the rice and stones flows from the hopper to the first separation bed [7].

### 3. Methodology

#### 3.1. Automatic rice seeder in laboratory scale

This research is quantitative research started from the observation field against seeding rice seeds manually until the process of planting rice on the farming town of Banyuasin, followed by the study design and design literature applications utilizing CAD. Design research is divided into four stages of activity i.e. planning, calculation of components, material selection, design and characterization tools series tools. Figure 3 shows the flowchart of research that will be done.

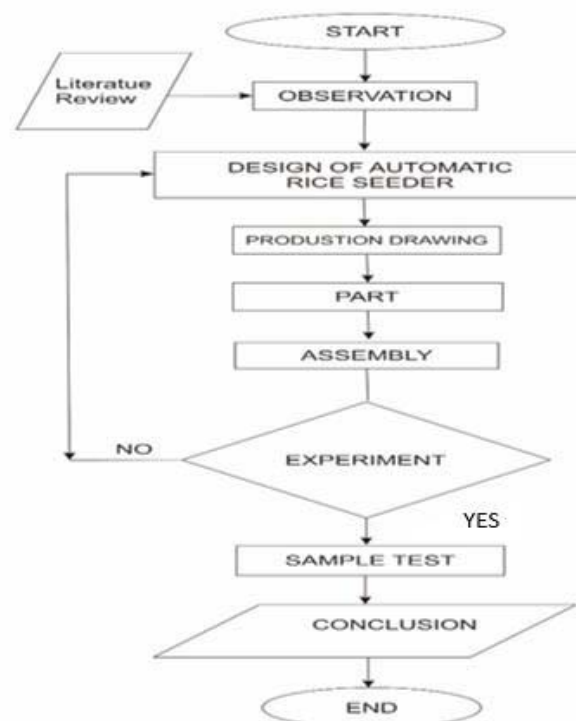

Figure 3. Flow chart



### 3.2. Automatic rice seed seeding mechanism with Android based

The mechanism for using tools sowing rice seeds. Started by setting up and entering 400 grams of rice on a reservoir of rice seeds. Next connect the 12V maximum electrical current from the power supply to port the Arduino Uno (AT Mega 328). When the light on the Arduino Uno has been lit, indicate the machine is ready to use. Open the automatic application of farming in android, then connect the bluetooth in android with a bluetooth connected on the machine. Once connected it will go straight to the main menu i.e. the choice of planting and flush on the on the application.

Select the logo "planting". On the look of android to perform seeding, we press the button "cropping", then the DC motor will turn on and makes a dapog move forward accompanied by the Servo motor that opens the valve for sow the rice. Figure 4 describes the flow of a program for rice seeds. When dapog to a white mark on the timing belt sensor photodiode to read a stop sign, the servo motor will move to shut the valve and seeding of DC motor is back lit to withdraw dapog. Process of care on a regular basis by performing at each watering dapog. Started by pressing the button on the display in the android select button "flush".

Figure 5 describes the flow of process watering rice seeds. The dc motor is turned on and then dapog move forward, when the first dapog is right above the sprinkler hose motor dc pauses with pauses around 5 second accompanied by pumps that will flush the dapog. Then dc motor moving back with the same process at dapog 2. Indicates the end of the process of watering, burning dc motor is moving backwards.

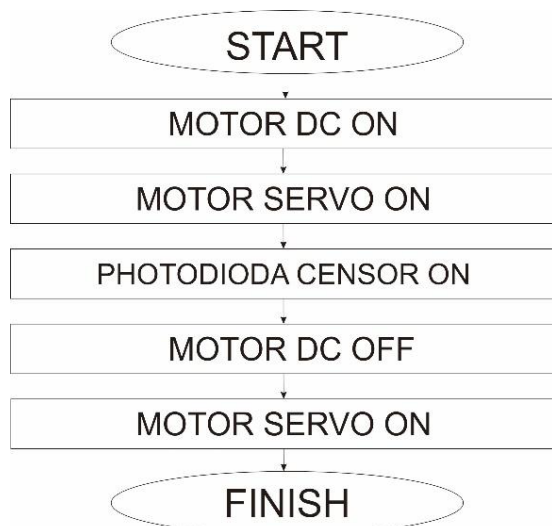

**Figure 4.** Automation process

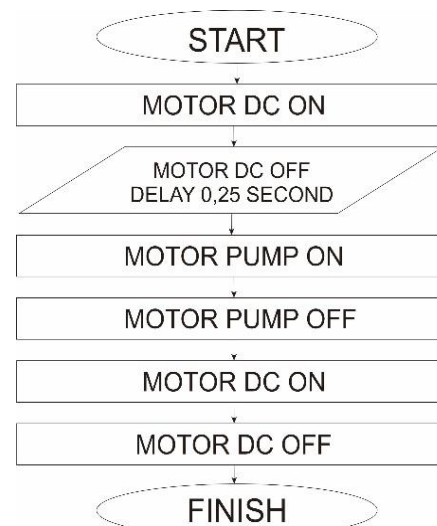

**Figure 5.** The process of watering rice

### 3.3. The basic construction automatic rice seeder in laboratory scale

In the planning tool for rice seeds this automatically, the first thing to do is making design and working principles of the tools and materials used, in order to facilitate the understanding and the manufacturing process, figure 5 display the basic construction automatic rice seeder in laboratory scale.

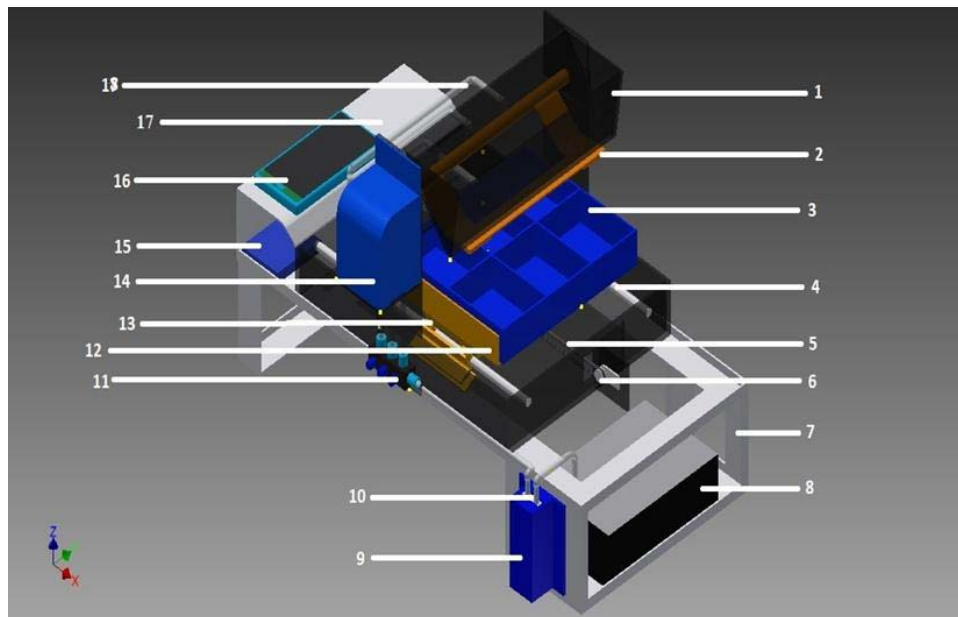

**Figure 6.** The basic construction tools planter rice seeds automatically scale laboratory.

Below are the names and functions of each component:

- |                         |                         |
|-------------------------|-------------------------|
| 1. Acrylic Frame        | 10. DC Water Pump       |
| 2. Rice Reservoir Valve | 11. Water Valve         |
| 3. Dapog                | 12. Dapog Runway        |
| 4. Shaft                | 13. Bearing             |
| 5. Timing Belt          | 14. Servo Motor         |
| 6. Gear                 | 15. Arduino uno         |
| 7. Aluminum Frame       | 16. Handphone (Android) |
| 8. Water Box            | 17. Motor DC            |
| 9. Housing Pump         | 18. Water Hose          |

#### 4. Experimental results and discussion

The test results showed the data capacity of the rice seeds are sown in holding an open rice valve speed is different. Then the results obtained shown in table 1.

**Table 1.** Testing the weight of rice seeds

No.	Time (s)	Experiment (gr)			Average
		I	II	III	
1	1/2	9,4	7,2	5,4	7,3
2	1	13,2	12	11,2	12,1
3	1 1/2	15,7	13,6	16,4	15,23
4	2	16,4	17,8	19,4	17,8

#### 4.1. The graph of the test results

The results of testing using a tool for rice seeds, then taken to the average weight of rice seeds per time. The test results obtained charts:

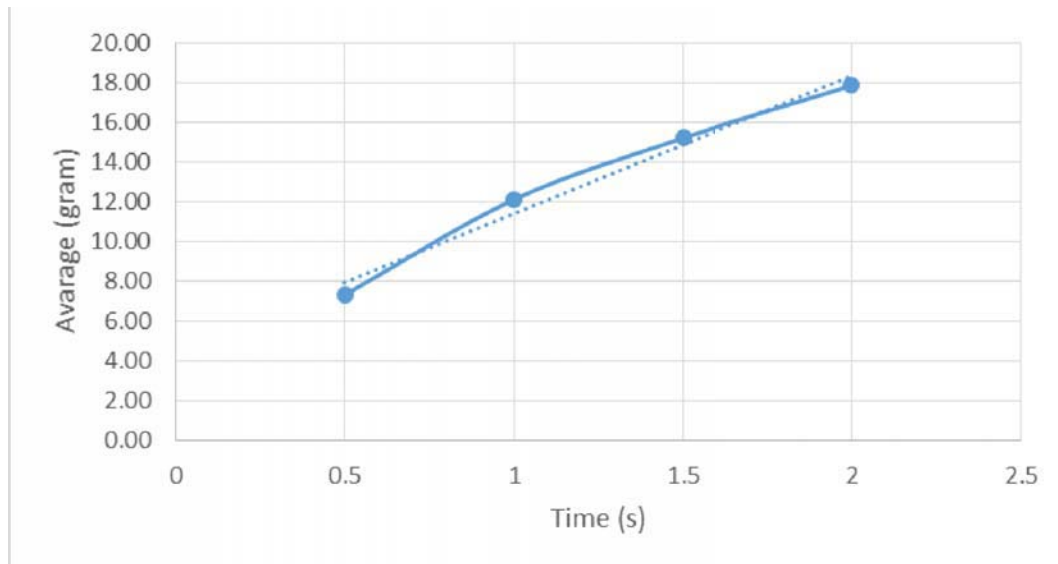

**Figure 7.** The graph capacity of rice seeds per unit of time

The weight of rice seeds depends on the speed of the holding valve open seeds. the longer the rice container valve is open the more seeds out of the box holding the rice seeds. Testing time watering rice seeds. This testing is carried out using 3 different size hose length and specified the volume of water discharge.

#### 4.2. Test result

The data of the test results of water watering with 3 different water hose length while the same volume of water that is 60 ml.

$$\begin{aligned}
 Q &= v/t \\
 &= ( [60 \text{ cm}]^3 / (48,4 \text{ s}) ) \\
 &= 1,24 \text{ cm}^3/\text{s}
 \end{aligned}$$

The speed water flow

$$\begin{aligned}
 V &= Q/A \\
 &= ( [1.24 \text{ cm}]^3 / \text{s} ) / ( 3,14/4 \times 9^{(2)} \text{ mm} ) \\
 &= ( 1,24 [ \text{cm} ]^3 / \text{s} ) / ( 0,785 \times 81 [ \text{mm} ]^2 ) \\
 &= ( 1,24 \times [10]^{-6} \text{ m}^3 / \text{s} ) / ( 63,58 \times [10]^{-6} \text{ m}^2 ) \\
 &= 0,0195 \text{ m/s}
 \end{aligned}$$

The results of future experiments done by pasting the same formula

**Table 2.** Testing watering use hoses size 420 mm

No	Experiment	$V (ml)$	$S (mm)$	$Q (cm^3/s)$	$V (m/s)$	$t (s)$
1	1	60	420	1,24	0,0195	48,4
2	2	60	420	1,28	0.0201	46,7
3	3	60	420	1,24	0.0195	48,4
Average				1,25	0,0197	47,8

**Table 3.** Testing watering use hoses size 470 mm.

No	Experiment	$V (ml)$	$S (mm)$	$Q (cm^3/s)$	$V (m/s)$	$t (s)$
1	1	60	470	1,19	0,0187	50,5
2	2	60	470	1,21	0,0190	49,7
3	3	60	470	1,22	0,0191	49,3
Average				1,21	0,0189	49,8

**Table 4.** Testing watering use hoses size 520 mm.

No	Experiment	$V (ml)$	$S (mm)$	$Q (cm^3/s)$	$V (m/s)$	$t (s)$
1	1	60	520	1,13	0,0177	52,7
2	2	60	520	1,12	0,0176	53,4
3	3	60	520	1,11	0,0174	54
Average				1,12	0.0411	53,6

The table above, it was concluded that:

- Longer hose size is also getting longer time watering.
- Longer hose size the smaller the velocity of the water.

Experiment by comparing the seeding using the tool automatically with the seeding manually. This experiment was done to calculate the seeding time per 6 dapog and performed by one person operated tool and one person sow manually.

Comparing test results data seeding using automatic with manual. Shown in Table 5 comparisons seeding

**Table 5.** Comparisons seeding using automatic and manual.

Seeding per 6 dapog		
	Tool	manual
Time (minute)	1 minute	10 minute

## 5. Conclusions

Design of automatic rice seeder laboratory scale, then it can be taken a few conclusions. Design of calculation components, the activator used is 12 volt dc electric motor speed average 3200 rpm. the framework uses aluminum L tensile straight 240 Mpa. Time required machine seeding rice seeds can be done within 2 minutes. Comparison of the work manually with 10 minutes. Stage experiments, tools that we create has exceeded the quantity and quality of machining process manually. This machine is also equipped with automatic system and less time than the previous process.

## 6. References

- [1] Prasetyo , etc .,\_\_\_\_\_ *Influence of Density On Seed Media to propagate against the performance of Rice Transplanter Type Crown Indo Jarwo 20-40 IHT*, Agricultural Technology Group, Vol 17 No. 3 pp 155 - 164
- [2] <http://sulbar.litbang.pertanian.go.id> (accessed 2016)
- [3] D D Patil & R M Phate., 2016, *Design & Development of Rice Planter Machine*, *Imperial Journal of Interdisciplinary Research (IJIR)*, Vol 2 Issue 8 2016, ISSN : 2454-1362, <http://www.onlinejournal.in>
- [4] T Rizaldi and Sumono., 2017, *Design and Performance Test of Seedling Machine* International Journal of Mechanical Engineering and Technology (IJMET) Vol 8 Issue 9 September 2017 pp 425-431 ISSN Print : 0976-6340 and ISSN Online : 0976-6359.
- [5] Oktaviandra, Robby., 2017, *Design Machine Handles Thresher Capacity 50 – 60 Kg/H*, Padang : Politeknik Negeri Padang.
- [6] H Cui, etc.,\_\_\_\_\_, *Design and Implementation of Automatic Control System for Rice Seed Tape Winding Units*, P. R. China, College of Engineering, Shenyang Agricultural University.
- [7] S. O. Ismail, S. J. Ojolo, J. I. Orisaleye and O. S. Okufo., 2013, *Design of a Rice De-stoner*, Int. J. of Mechanical Computational and Manufacturing Research, Vol. 2. No.3, (2013) 54–64, ISSN: 2301-4148.



**2<sup>nd</sup> FIRST 2018 INTERNATIONAL CONFERENCE**  
FORUM IN RESEARCH, SCIENCE, AND TECHNOLOGY (FIRST)  
OCTOBER 30-31, 2018

# CERTIFICATE OF APPRECIATION

is awarded to

**ROMI WILZA**

in recognition & appreciation of the contribution as

**CO-AUTHOR**

In

**2<sup>nd</sup> FIRST 2018 Coaching Clinic & Research Writing Workshop**

Held On October 31, 2018  
HORISON ULTIMA HOTEL  
Palembang, Indonesia

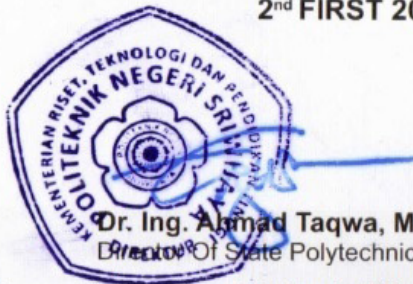

**Dr. Ing. Ahmad Taqwa, M.T.**  
Director Of State Polytechnic Of Sriwijaya

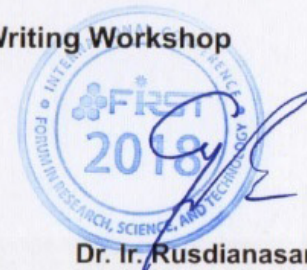

**Dr. Ir. Rusdianasari, M.Si.**  
Chair Of 2<sup>nd</sup> FIRST 2018

Organized By :

Collaborate With :



الجامعة الإسلامية العالمية ماليزيا  
INTERNATIONAL ISLAMIC UNIVERSITY MALAYSIA  
بِسْمِ اللَّهِ الرَّحْمَنِ الرَّحِيمِ



University of Cologne



University of  
Sunderland