



KARTU ASISTENSI TUGAS AKHIR

Nama Mahasiswa : Dwi Andra Octoni Darma (061940111879)  
Rangga Isnanda (061940111891)  
Jurusan / Program Studi : Teknik Sipil / D IV Perancangan Jalan dan Jembatan  
Judul Laporan : Perencanaan Geometrik dan Tebal Perkerasan Kaku Jalan Lingkar Barat SP. *Sport Center* – Bukit Sulap Kota Lubuklinggau STA 00+000 – 08+050 Provinsi Sumatera Selatan  
Dosen Pembimbing I : Mahmuda, S.T., M.T.

No.	Tanggal	Uraian	Paraf
	14 / 3 / 23	- Konsultasi pemilihan judul skripsi	
	28 / 3 / 23	- Konsultasi kelengkapan data perencanaan - Lengkapi data yang kurang	
	11 / 4 / 23	- Bimbingan bab 1 - Perbaiki latar belakang dan tambahkan tujuan dan manfaat - Konsultasi mengenai proposal skripsi	
	2 / 5 / 23	- Bimbingan proposal skripsi - Boleh mengikuti seminar proposal pada tahun akademik 2022/2023	



KARTU ASISTENSI TUGAS AKHIR

No.	Tanggal	Uraian	Paraf
	16/5/23	<ul style="list-style-type: none"><li>- Perbaiki tata penulisan bab II</li><li>- Perhitungan koordinat, <u>Acc</u></li><li>- Asistensi LHR</li></ul>	
	30/5/23	<ul style="list-style-type: none"><li>- LHR, <u>Acc</u></li><li>- Perbaiki perhitungan sudut tangen dan bearing</li><li>- Gambar diberi keterangan</li><li>- lanjutkan perhitungan tikungan</li></ul>	
	19/6/23	<ul style="list-style-type: none"><li>- Stationing dan overlapping. <u>Acc</u></li><li>- Perbaiki Alinyemen Horizontal dan Vertikal.</li><li>- Perbaiki Pelebaran tikungan</li><li>- Perhitungan sudut, <u>Acc</u></li></ul>	
	7/7/23	<ul style="list-style-type: none"><li>- Perhitungan galian dan timbunan. <u>Acc</u></li><li>- Perbaiki Drainase</li><li>- Potongan memampang, <u>Acc</u></li></ul>	



## KARTU ASISTENSI TUGAS AKHIR

No.	Tanggal	Uraian	Paraf
	10/7/23	<ul style="list-style-type: none"><li>- Perbaiki tebal perkeraan</li><li>- Perhitungan galian dan timbunan (perbaiki tabel).</li><li>- Perhitungan drainase, Acc</li><li>- Bab III, <u>Acc</u></li></ul>	
	24/7/23	<ul style="list-style-type: none"><li>- Gambar potongan memanjang dan melintang, <u>Acc</u></li><li>- Perbaiki syarat RKS</li></ul>	
	27/7/23	<ul style="list-style-type: none"><li>- Perbaiki NWP dan kurva s</li><li>- RAB, <u>Acc</u></li><li>- Perbaiki judul tabel dan gambar</li><li>- Gambar potongan melintang (perbaiki angka yang salah)</li></ul>	
	28/7/23	<ul style="list-style-type: none"><li>- NWP dan kurva s, <u>Acc</u></li><li>- Bab IV, <u>Acc</u></li><li>- Bab V, <u>Acc</u></li><li>- Boleh mengikuti sidang skripsi pada tahun akademik 2022/2023</li></ul>	



KARTU ASISTENSI TUGAS AKHIR

Nama Mahasiswa : Dwi Andra Octoni Darma (061940111879)

Rangga Isnanda (061940111891)

Jurusan / Program Studi : Teknik Sipil / D IV Perancangan Jalan dan Jembatan

Judul Laporan : Perencanaan Geometrik dan Tebal Perkerasan Kaku Jalan Lingkar Barat SP. Sport Center – Bukit Sulap Kota Lubuklinggau STA 00+000 – 08+150 Provinsi Sumatera Selatan

Dosen Pembimbing II : Drs. Bambang Hidayat Fuady, S.T., M.T., M.M

No.	Tanggal	Uraian	Paraf
	29/3/23	- Penyajian & data kontur agar dapat ditentukan konturnya.	
	3/4/23	- Kontur balok & pabel. - Malas buat cari titik koordinat. - Penyajian & data qz balok	
	16/5/23	- Trace balok & pabel di sta 0+000 s/d 08+150. - Tandai awal ulir & buat di gambar	







## KARTU ASISTENSI TUGAS AKHIR

No.	Tanggal	Uraian	Paraf
	16/5/23	<ul style="list-style-type: none"><li>- Perhitungan koor &amp; nat, aee.</li><li>- Data CHR 2022 &amp; kerpele/8/2024 jad. <math>n_{asal} = 2</math>, <math>i</math> (arteri) = 483</li><li>- <math>i</math> sebelum &amp; buka hrs lebih besar dr <math>i</math> asal ambil <math>7\%</math> ahr <math>Umar(u) : 70\%</math></li></ul>	
	29/5/23	<ul style="list-style-type: none"><li>- Perbaiki tanda or &amp; nat (4)</li><li>- Perbaiki perdit srt <math>\Delta</math> (cek)</li><li>- Perbaiki tab tulis</li></ul>	
	30/5/23	<ul style="list-style-type: none"><li>- Perhitungan kelengkapan Ah. Alp uanf. &amp; cel saat stationing</li></ul>	

- Kelengkapan dan kelengkapan
- Cek, utlra s/d tle-f







KARTU ASISTENSI TUGAS AKHIR

5/6/2023		<ul style="list-style-type: none"> <li>- Perbaiki dsr super elevasi, resue ds leveler</li> <li>- Tilung 3, sd uji di gant</li> <li>- Cek kembali poluknya talang</li> <li>- Cek / perbaiki stationing</li> </ul>	
7/6/2023		<ul style="list-style-type: none"> <li>- Ckr super elevasi Arkenyan, Aee</li> <li>- Perbaiki poluknya stationing dan tambal kan ya rali yg di dapat the bisa di simpulkan tal overlap.</li> </ul>	
12/6/2023		<ul style="list-style-type: none"> <li>- Cek antara alu. Hirtle &amp; vertle, agar jadi tal pd. sempit yg sama persis</li> </ul>	



**KARTU ASISTENSI TUGAS AKHIR**

No.	Tanggal	Uraian	Paraf
	19/6/23	<ul style="list-style-type: none"> <li>- Stationing &amp; over lapping → Acc</li> <li>- Al. vertikal → Acc (sbr. vertikal &amp; vertikal)</li> <li>- Jeda gns read t = 1 jam layang &amp; sumber</li> <li>- Cengukan ke. Pragma pelepasan sbr, garis turban</li> </ul>	
		<ul style="list-style-type: none"> <li>* Cek lebar min pelepasan telaya di buker.</li> <li>* Cek &amp; SNI Beton Pd.T - 14 - 2003</li> </ul>	
	22/6/23	<ul style="list-style-type: none"> <li>- Babar pelepasan pelepasan telaya</li> <li>- Pragma pelepasan (kelayan) → Acc</li> </ul>	
		<ul style="list-style-type: none"> <li>- Cengukan</li> </ul>	





KARTU ASISTENSI TUGAS AKHIR

No.	Tanggal	Uraian	Paraf
	7/7/23	<ul style="list-style-type: none"><li>- Hitung galian &amp; tumb OK.</li><li>- Pot melintang.</li><li>- Aceq</li><li>- Pot memanjang &amp; super elevasi OK</li><li>- Drainase, lelat Kontur &amp; elevasi rencana jalan</li></ul>	
	10/7/23	<ul style="list-style-type: none"><li>- Revisi tebal (Aspal) perkerasan OK</li><li>- Layout ke MP.</li><li>- &amp; Bagunan pejalan kaki</li></ul>	
	24/7/2023	<ul style="list-style-type: none"><li>- Mel W, Man Pro Nilai Is &amp; Bulat ke</li><li>- Nilai kontrol (ATS) sesuai lay ds. Kondisi rencana jalan</li></ul>	





KARTU ASISTENSI TUGAS AKHIR

No.	Tanggal	Uraian	Paraf
	27/7/23	<ul style="list-style-type: none"><li>- NWP, perbaiki</li><li>- Scarve, Aee</li><li>- RAB, Aee</li><li>- Gambar, Aee</li><li>tugas ulang</li><li>di deskusikan.</li><li>- Bab I, Aee</li><li>- Daftar Pustaka</li><li>Aee</li><li>- Lembaran /</li><li>paper</li><li>- Tgl. 28/7/23</li><li>bers print out</li><li>lap. (80 p x</li><li>o/). Releasung</li></ul>	



KEMENTERIAN PENDIDIKAN DAN KEBUDAYAAN

POLITEKNIK NEGERI SRIWIJAYA

Jalan Srijaya Negara, Palembang 30139

Telp. 0711-353414 Fax. 0711-355918

Website : [www.polsri.ac.id](http://www.polsri.ac.id) E-mail : [info@polsri.ac.id](mailto:info@polsri.ac.id)

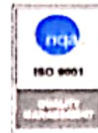

**LEMBAR REKOMENDASI SIDANG SKRIPSI**

Pembimbing Skripsi Memberikan Rekomendasi Kepada :

Nama : Rangga Isnanda

NIM : 061940111891

Jurusan : Teknik Sipil

Program Studi : D-IV Perancangan Jalan dan Jembatan

Judul Laporan : Perencanaan Geometrik dan Tebal Perkerasan Kaku Pada Jalan

Lingkar Barat SP. *Sport Center* – Bukit Sulap Kota Lubuklinggau

STA 00+000 – 08+150 Provinsi Sumatera Selatan

Mahasiswa tersebut telah memenuhi persyaratan dan dapat mengikuti sidang skripsi pada tahun akademik 2022/2023.

Palembang, ~~28~~ Juli 2023

Pembimbing I

Pembimbing II

Mahmuda, S.T., M.T.

Drs. Bambang H. Fuady, S.T., MM, M.T.

NIP. 196207011989032002

NIP. 195807161986031004

KEMENTERIAN PENDIDIKAN DAN KEBUDAYAAN  
**POLITEKNIK NEGERI SRIWIJAYA**  
Jalan Srijaya Negara, Palembang 30139  
Telp. 0711-353414 Fax. 0711-355918  
Website : [www.polsri.ac.id](http://www.polsri.ac.id) E-mail : [info@polsri.ac.id](mailto:info@polsri.ac.id)



**LEMBAR REKOMENDASI SIDANG SKRIPSI**

Pembimbing Skripsi Memberikan Rekomendasi Kepada :

Nama : Dwi Andra Octoni Darma

NIM : 061940111879

Jurusan : Teknik Sipil

Program Studi : D-IV Perancangan Jalan dan Jembatan

Judul Laporan : Perencanaan Geometrik dan Tebal Perkerasan Kaku Pada Jalan  
Lingkar Barat SP. *Sport Center* – Bukit Sulap Kota Lubuklinggau  
STA 00+000 – 08+150 Provinsi Sumatera Selatan

Mahasiswa tersebut telah memenuhi persyaratan dan dapat mengikuti sidang skripsi pada tahun akademik 2022/2023.

Palembang, ~~28~~ Juli 2023

Pembimbing I

Pembimbing II



Mahmuda, S.T., M.T.

Drs. Bambang H. Fuady, S.T., MM, M.T.

NIP. 196207011989032002

NIP. 195807161986031004



**PEMERINTAH KOTA LUBUKLINGGAU**  
**DINAS PEKERJAAN UMUM & PENATAAN RUANG**  
Jalan Dempo Raya Kel. Air Kuti Lubuklinggau Timur  
Kota Lubuklinggau 31625



**CBR DCP (Dinamic Cone Penetrometer)**

Jalan Lingkar Barat Kota Lubuklinggau

No	STA	CBR (%)	Faktor Kondisi Musim	CBR Desain (%)
1	0+000	10,6	0,9	9,5
2	0+200	8,9	0,9	7,9
3	0+300	7,5	0,9	6,2
4	0+500	9,5	0,9	8,3
5	0+700	5,7	0,9	4,7
6	0+900	6,8	0,9	5,6
7	1+100	8,6	0,9	7,9
8	1+300	9,5	0,9	8,7
9	1+500	12,1	0,9	11
10	1+700	10,1	0,9	9,1
11	1+900	11	0,9	10,2
12	2+100	8,2	0,9	7,3
13	2+300	12,4	0,9	11,5
14	2+500	10,1	0,9	9
15	2+700	11	0,9	10,1
16	2+900	8,2	0,9	7,4
17	3+100	12,4	0,9	11,5
18	3+300	11,4	0,9	10,7
19	3+500	8,2	0,9	7,4
20	3+700	9,8	0,9	8,6
21	3+900	8,7	0,9	7,5
22	4+100	11,0	0,9	10,1
23	4+300	10,8	0,9	9,9
24	4+500	11,6	0,9	10,4
25	4+700	7,8	0,9	6,2
26	4+900	11,4	0,9	10,3
27	5+100	11,5	0,9	10,3
28	5+300	12,7	0,9	11,4
29	5+500	9,9	0,9	8,9
30	5+700	10,6	0,9	9,5
31	5+900	21,8	0,9	19,6
32	6+100	9,2	0,9	8,2
33	6+300	10	0,9	9





**PEMERINTAH KOTA LUBUKLINGGAU**  
**DINAS PEKERJAAN UMUM & PENATAAN RUANG**  
Jalan Dempo Raya Kel. Air Kuti Lubuklinggau Timur  
Kota Lubuklinggau 31625



34	6+500	8,9	0,9	8
35	6+700	10,3	0,9	9,3
36	6+900	13,3	0,9	11,9
37	7+100	11,5	0,9	10,3
38	7+300	8,9	0,9	8
39	7+500	8	0,9	7,2
40	7+700	9,8	0,9	8,8
41	7+900	13,4	0,9	12
42	8+100	10,9	0,9	9,8
43	8+300	10,3	0,9	9,3
44	8+500	12,7	0,9	11,4
45	8+700	10,3	0,9	9,3
46	8+900	12,5	0,9	11,3
47	9+100	17,8	0,9	16,1
48	9+300	13,5	0,9	12,2
49	9+500	15,1	0,9	13,6
50	9+700	11,6	0,9	10,4
51	9+900	10,3	0,9	9,3
52	10+100	9,2	0,9	8,2
53	10+300	11,5	0,9	10,3
54	10+500	17,4	0,9	15,6
55	10+700	13,9	0,9	12,5
			<b>CBR Rata-Rata</b>	<b>9,7</b>



**PEMERINTAH KOTA LUBUKLINGGAU**  
**DINAS PEKERJAAN UMUM & PENATAAN RUANG**  
Jalan Dempo Raya Kel. Air Kuti Lubuklinggau Timur  
Kota Lubuklinggau 31625



**Data Curah Hujan Kota Lubuklinggau Provinsi Sumatera Selatan**

Bulan	Curah Hujan 2018	Bulan	Curah Hujan 2019	Bulan	Curah Hujan 2020	Bulan	Curah Hujan 2021	Bulan	Curah Hujan 2022
Januari	241,90	Januari	249	Januari	114,30	Januari	347,50	Januari	450
Februari	190,30	Februari	372,30	Februari	298,50	Februari	577	Februari	306,10
Maret	420	Maret	394	Maret	367,90	Maret	600	Maret	319
April	395,90	April	427,20	April	396,50	April	349,50	April	314
Mei	295,40	Mei	157,50	Mei	265,30	Mei	583,50	Mei	342
Juni	192,20	Juni	204	Juni	133	Juni	218,50	Juni	183,20
Juli	190,90	Juli	89	Juli	74,90	Juli	221,50	Juli	557
Agustus	42,50	Agustus	2,20	Agustus	48,60	Agustus	194	Agustus	418
September	38,60	September	63,70	September	116	September	426	September	337,20
Oktober	101,40	Oktober	157,1	Oktober	251,80	Oktober	268	Oktober	375,50
November	131,30	November	148,9	November	333,60	November	488	November	453
Desember	180,90	Desember	394	Desember	228,20	Desember	281	Desember	454
Rata - Rata	201,78	Rata - Rata	222	Rata - Rata	219,05	Rata - Rata	379,54	Rata - Rata	376

Disetujui Oleh :  
PEJABAT PEMBUAT KOMITMEN (PPK)  
DINAS PEKERJAAN UMUM & PENATAAN RUANG  
KOTA LUBUK LINGGAU

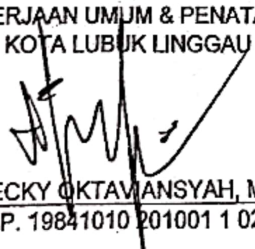
  
DECKY OKTAVANSYAH, MT  
NIP. 19841010 201001 1 027

Diketahui Oleh :  
KEPALA DINAS  
PEKERJAAN UMUM & PENATAAN RUANG  
KOTA LUBUK LINGGAU

ACHMAD ASRIL ASRI, ST, M.Si  
NIP. 19741214 200804 1 001



PEMERINTAH KOTA LUBUKLINGGAU  
DINAS PEKERJAAN UMUM & PENATAAN RUANG  
Jalan Dempo Raya Kel. Air Kuti Lubuklinggau Timur  
Kota Lubuklinggau 31625



**Rekap Lalu Lintas Harian Rata-rata Jalan Lingkar Barat Kota Lubuklinggau**

NO	Gol.	Jenis Kendaraan	Sumbu	LHR					Satuan
				2018	2019	2020	2021	2022	
1	1	SEPEDA MOTOR, SKUTER, KEND. RODA TIGA	1.1	861	1516	2869	2317	3416	kend
2	2	SEDAN, JEEP, STATION WAGON	1.1	438	638	1384	1057	1758	kend
3	3	OPLET, PICK UP OPLET, SUB URBAN, COMBI, MINIBUS	1.2	10	22	435	310	659	kend
4	4	PICK UP, MICRO TRUCK, MOBIL HANTARAN	1.2	139	189	93	74	157	kend
5	5.A	BUS KECIL	1.1	11	19	21	9	35	kend
6	5.B	BUS BESAR	1.2	6	11	19	10	16	kend
7	6.A	TRUK RINGAN 2 SUMBU	1.2	131	203	815	524	761	kend
8	6.B	TRUK SEDANG 2 SUMBU	1.2	101	94	67	49	53	kend
9	7.A	TRUK 3 SUMBU	1.2	2	6	10	4	7	kend
10	7.B	TRUK GANDENG	1.2	0	0	0	1	4	kend
11	7.C	TRUK SEMI TRALIER 122-22	1.22-22	0	0	2	4	1	kend
12	8	TRUK TRAILER 122-2222	1.22-2222	0	0	0	0	0	kend
Jumlah Kendaraan				1699	2698	5715	4359	6867	

Disetujui Oleh :  
PEJABAT PEMBUAT KOMITMEN (PPK)  
DINAS PEKERJAAN UMUM & PENATAAN RUANG  
KOTA LUBUK LINGGAU

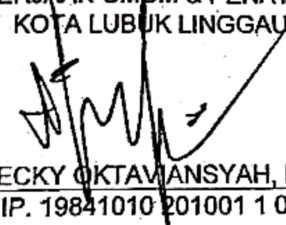
  
DECKY OKTAVIANSYAH, MT  
NIP. 19841010 201001 1 027

Diketahui Oleh :  
KEPALA DINAS  
PEKERJAAN UMUM & PENATAAN RUANG  
KOTA LUBUK LINGGAU

ACHMAD ASRIL ASRI, ST, M.Si  
NIP. 19741214 200804 1 001

## DAFTAR HARGA DASAR SATUAN UPAH

No.	URAIAN	KODE	SATUAN	HARGA SATUAN (Rp.)	KETERANGAN
1.	Pekerja	(L01)	Jam	17.484,00	
2.	Tukang	(L02)	Jam	20.956,00	
3.	M a n d o r	(L03)	Jam	20.956,00	
4.	Operator	(L04)	Jam	27.404,00	
5.	Pembantu Operator	(L05)	Jam	17.484,00	
6.	Sopir / Driver	(L06)	Jam	27.404,00	
7.	Pembantu Sopir / Driver	(L07)	Jam	17.484,00	
8.	Mekanik	(L08)	Jam	27.404,00	
9.	Pembantu Mekanik	(L09)	Jam	17.484,00	
10.	Kepala Tukang	(L10)	Jam	24.800,00	



## DAFTAR BIAYA SEWA PERALATAN PER JAM KERJA

No.	URAIAN	KODE	HP	KAP.	HARGA ALAT	BIAYA SEWA ALAT/JAM (di luar PPN)	KET.
1	ASPHALT MIXING PLANT	E01	294,0	60,0 T/jam	5.093.955.000	9.571.336,76	
2	ASPHALT FINISHER	E02	72,4	10,0 Ton	1.924.965.000	926.663,88	
3	ASPHALT SPRAYER	E03	4,0	850,0 Liter	75.951.000	85.293,87	
4	BULLDOZER 100-150 HP	E04	155,0		785.700.000	690.984,85	
5	COMPRESSOR 4000-6500 LAM	E05	60,0	5.000,0 CPM/(L/m)	96.030.000	247.965,27	
6	CONCRETE MIXER 0.3-0.6 M3	E06	20,0	500,0 Liter	153.211.500	198.997,50	
7	CRANE 10-15 TON	E07	138,0	15,0 Ton	1.299.024.000	755.584,40	
8	DUMP TRUCK 3.5 TON	E08	100,0	3,5 Ton	165.870.000	384.665,20	
9	DUMP TRUCK 10 TON	E09	190,0	10,0 Ton	183.330.000	660.678,10	
10	EXCAVATOR 80-140 HP	E10	133,0	0,9 M3	1.265.850.000	732.973,57	
11	FLAT BED TRUCK 3-4 M3	E11	190,0	10,0 ton	288.788.400	684.507,36	
12	GENERATOR SET	E12	180,0	135,0 KVA	180.711.000	629.856,57	
13	MOTOR GRADER >100 HP	E13	135,0	10.800,0	764.748.000	625.791,08	
14	TRACK LOADER 75-100 HP	E14	70,0	0,8 M3	473.166.000	363.412,23	
15	WHEEL LOADER 1.0-1.6 M3	E15	96,0	1,5 M3	492.372.000	446.349,32	
16	THREE WHEEL ROLLER 6-8 T	E16	55,0	8,0 Ton	305.550.000	280.193,30	
17	TANDEM ROLLER 6-8 T.	E17	82,0	8,1 Ton	659.486.025	441.788,58	
18	TIRE ROLLER 8-10 T.	E18	100,5	9,0 Ton	698.400.000	506.506,56	
19	VIBRATORY ROLLER 5-8 T.	E19	82,0	7,1 Ton	627.501.488	434.561,39	
20	CONCRETE VIBRATOR	E20	5,5	25,0	3.492.000	67.100,39	
21	STONE CRUSHER	E21	220,0	50,0 T/jam	882.593.983	926.856,22	
22	WATER PUMP 70-100 mm	E22	6,0		4.365.000	64.283,84	
23	WATER TANKER 3000-4500 L.	E23	100,0	4.000,0 Liter	82.935.000	365.925,30	
24	PEDESTRIAN ROLLER	E24	8,8	835,00 Ton	130.950.000	109.230,18	
25	TAMPER	E25	4,7	121,00 Ton	14.841.000	70.075,69	
26	JACK HAMMER	E26	0,0	1.330,00	30.555.000	51.792,17	
27	FULVI MIXER	E27	345,0	2.005,00	785.700.000	1.734.812,07	
28	CONCRETE PUMP	E28	100,0	8,00 M3	98.212.500	367.866,33	
29	TRAILER 20 TON	E29	175,0	20,00 Ton	523.800.000	684.206,76	
30	PILE DRIVER + HAMMER	E30	25,0	2,50 Ton	763.875.000	293.066,68	
31	CRANE ON TRACK 35 TON	E31	125,0	35,0 Ton	742.050.000	579.015,68	
32	WELDING SET	E32	40,0	250,0 Amp	15.277.500	169.259,05	
33	BORE PILE MACHINE	E33	150,0	2.000,0 Meter	1.964.250.000	911.952,75	
34	ASPHALT LIQUID MIXER	E34	5,0	1.000,0 Liter	13.095.000	63.266,30	
35	TRONTON	E35	150,0	15,0 Ton	392.850.000	743.432,77	
36	COLD MILLING	E36	248,0	1.000,0 m	4.316.985.000	1.805.014,59	
37	ROCK DRILL BREAKER	E37	3,0		785.700.000	306.241,40	
38	COLD RECYCLER	E38	900,0	2,2 M	17.023.500.000	6.647.143,36	
39	HOT RECYCLER	E39	400,0	3,0 M	25.535.250.000	7.058.961,74	
40	AGGREGAT (CHIP) SPREADER	E40	115,0	3,5 M	344.835.000	686.574,17	
41	ASPHALT DISTRIBUTOR	E41	115,0	4.000,0 Liter	344.835.000	505.416,54	
42	SLIP FORM PAVER	E42	105,0	2,5 M	1.167.325.714	643.075,92	
43	CONCRETE PAN MIXER	E43	134,0	600,0 Liter	873.000.000	815.683,90	
44	CONCRETE BREAKER	E44	290,0	20,0 m3/jam	785.700.000	1.134.054,34	
45	ASPAHLT TANKER	E45	190,0	4.000,0 liter	436.500.000	763.649,11	
46	CEMENT TANKER	E46	190,0	4.000,0 liter	436.500.000	711.168,31	
47	CONDRETE MIXER (350)	E47	20,0	350,0 liter	30.555.000	116.546,98	
48	VIBRATING RAMMER	E48	4,2	80,0 KG	17.460.000	69.593,40	
49	TRUK MIXER (AGITATOR)	E49	220,0	5,0 M3	654.750.000	857.888,85	
50	BORE PILE MACHINE	E50	125,0	60,0 CM	1.021.410.000	788.020,74	
51	CRANE ON TRACK 75-100 TON	E51	200,0	75,0 Ton	785.700.000	827.018,68	
52	BLENDING EQUIPMENT	E52	50,0	30,0 Ton	436.500.000	298.870,02	
53	ASPHALT LIQUID MIXER	E34a	40,0	20.000,0 Liter	13.095.000	169.070,39	

## DAFTAR HARGA DASAR SATUAN BAHAN

No.	URAIAN	KODE	SATUAN	HARGA SATUAN (Rp.)	KETERANGAN
1	Pasir Pasang (Sedang)	M01b	M3	146.653,20	
2	Pasir Beton (Kasar)	M01a	M3	188.478,00	
3	Pasir Halus (untuk HRS)	M01c	M3	402.919,50	
4	Pasir Urug (ada unsur lempung)	M01d	M3	188.478,00	
5	Batu Kali	M02	M3	282.650,40	
6	Agregat Kasar	M03	M3	402.919,50	
7	Agregat Halus	M04	M3	402.919,50	
8	Filler	M05	Kg	3.529,80	
9	Batu Belah / Kerakal	M06	M3	393.472,80	
10	Gravel	M07	M3	425.840,40	
11	Bahan Tanah Timbunan	M08	M3	39.960,00	
12	Bahan Pilihan	M09	M3	66.600,00	
13	Aspal	M10	Kg	16.400,00	
14	Kerosen / Minyak Tanah	M11	Liter	8.258,40	
15	Semen / PC (50kg)	M12	Zak	97.137,43	
16	Semen / PC (kg)	M12	Kg	1.942,75	
17	Besi Beton	M13	Kg	13.526,46	
18	Kawat Beton	M14	Kg	22.644,00	
19	Kawat Bronjong	M15	Kg	48.684,60	
17	Sirtu	M16	M3	200.000,00	
18	Cat Marka (Non Thermoplas)	M17a	Kg	58.666,61	
19	Cat Marka (Thermoplastic)	M17b	Kg	58.666,61	
18	Paku	M18	Kg	24.908,40	
19	Kayu Perancah	M19	M3	1.998.000,00	
20	Bensin	M20	Liter	13.120,20	
21	Solar	M21	Liter	13.120,20	
22	Minyak Pelumas / Olie	M22	Liter	57.942,00	
23	Plastik Filter	M23	M2	1.998,00	
24	Pipa Galvanis Dia. 1.6"	M24	Batang	0,00	
25	Pipa Porus	M25	M'	0,00	
26	Bahan Agr.Base Kelas A	M26	M3	411.782,19	
27	Bahan Agr.Base Kelas B	M27	M3	0,00	
28	Bahan Agr.Base Kelas C	M28	M3	0,00	
29	Bahan Agr.Base Kelas C2	M29	M3	0,00	
30	Geotextile	M30	M2	0,00	
23	Aspal Emulsi	M31	Kg	13.832,82	
24	Gebalan Rumput	M32	M2	7.192,80	
25	Thinner	M33	LITER	31.187,45	
26	Glass Bead	M34	Kg	959.040,00	
27	Pelat Rambu (Eng. Grade)	M35a	BH	363.636,00	
28	Pelat Rambu (High I. Grade)	M35b	BH	519.480,00	
29	Rel Pengaman	M36	M'	549.450,00	
30	Beton K-250	M37	M3	2.256.528,11	
31	Baja Tulangan (Polos) U24	M39a	Kg	12.000,00	
32	Baja Tulangan (Ulir) D32	M39b	Kg	22.803,84	
33	Kapur	M40	M3	1.641.107,92	
34	Chipping	M41	M3	402.919,50	
35	Chipping (kg)	M41kg	Kg	213,77	
36	Cat	M42	Kg	36.630,00	
37	Pemantul Cahaya (Reflector)	M43	Bh.	16.783,20	
24	Pasir Urug	M44	M3	126.140,40	
25	Arbocell	M45	Kg.	42.624,00	



No.	URAIAN	KODE	SATUAN	HARGA SATUAN (Rp.)	KETERANGAN
26	Baja Bergelombang	M46	Kg	16.650,00	
27	Beton K-125	M47	M3	1.568.700,54	
28	Baja Struktur	M48	Kg	38.494,80	
29	Tiang Pancang Baja	M49	M'	33.629,50	
30	Tiang Pancang Beton Pratekan	M50	M3	564.711,96	
31	Kawat Las	M51	Dos	21.312,00	
32	Besi Pipa (haru)	M52	Kg	33.966,00	
25	Minyak Fluks	M53	Liter	8.307,68	
26	Bunker Oil	M54	Liter	3.996,00	
27	Asbuton Halus	M55	Ton	432.900,00	
28	Baja Prategang	M56	Kg	10.656,00	
29	Baja Tulangan (Polos) U32	M57a	Kg	11.188,80	
30	Baja Tulangan (Ulir) D39	M39c	Kg	11.255,40	
31	Baja Tulangan (Ulir) D48	M39d	Kg	11.988,00	
32	PCI Girder L=17m	M58a	Buah	114.552.000,00	
33	PCI Girder L=21m	M58b	Buah	129.204.000,00	
34	PCI Girder L=26m	M58c	Buah	165.168.000,00	
35	PCI Girder L=32m	M58d	Buah	209.124.000,00	
36	PCI Girder L=36m	M58e	Buah	223.776.000,00	
37	PCI Girder L=41m	M58f	Buah	255.744.000,00	
38	Beton K-300	M59	M3	2.389.316,81	
28	Beton K-175	M60	M3	1.716.909,97	
29	Cerucuk	M61	Btg	6.660,00	
30	Elastomer	M62	buah	399.600,00	
31	Bahan pengawet: kreosot	M63	liter	6.660,00	
32	Mata Kucing	M64	buah	99.900,00	
33	Anchorage	M65	buah	639.360,00	
29	Anti strpping agent	M66	liter	62.374,90	
30	Bahan Modifikasi	M67	Kg	1.332,00	
31	Beton K-500	M68	M3	3.175.444,18	
32	Beton K-400	M69	M3	2.938.102,80	
33	Ducting (Kabel prestress)	M70	M'	199.800,00	
34	Ducting (Strand prestress)	M71	M'	66.600,00	
35	Beton K-350	M72	M3	2.845.504,49	
36	Multipleks 12 mm	M73	Lbr	241.758,00	
37	Elastomer jenis 1	M74a	buah	513.486,00	
38	Elastomer jenis 2	M74b	buah	865.800,00	
39	Elastomer jenis 3	M74c	buah	1.116.216,00	
40	Expansion Tipe Joint Asphaltic Plug	M75d	M	1.332.000,00	
41	Expansion Join Tipe Rubber	M75e	M	1.598.400,00	
42	Expansion Join Baja Siku	M75f	M	366.300,00	
43	Marmer	M76	Buah	532.800,00	
44	Kerb Type A	M77	Buah	59.940,00	
45	Paving Block	M78	Buah	53.280,00	
46	Mini Timber Pile	M79	Buah	35.964,00	
47	Expansion Joint Tipe Torma	M80	M1	1.598.400,00	
48	Strip Bearing	M81	Buah	305.694,00	
49	Joint Socket Pile 35x35	M82	Set	809.190,00	
50	Joint Socket Pile 16x16x16	M83	Set	89.910,00	
51	Mikro Pile 16x16x16	M84	M1	80.919,00	
52	Matras Concrete	M85	Buah	539.460,00	
53	Assetilline	M86	Botol	305.694,00	
54	Oxygen	M87	Botol	152.847,00	
55	Batu Bara	M88	Kg	799,20	
56	Pipa Galvanis Dia 3"	M24a	M	93.608,96	

No.	URAIAN	KODE	SATUAN	HARGA SATUAN (Rp.)	KETERANGAN
57	Pipa Galvanis Dia 1,5"	M24b	M	55.448,50	
31	Agregat Pecah Mesin 0-5 mm	M91	M3	402.919,50	
32	Agregat Pecah Mesin 5-10 & 10-20 mm	M92	M3	402.919,50	
33	Agregat Pecah Mesin 20-30 mm	M93	M3	402.919,50	
34	Joint Sealent	M94	Kg	45.421,20	
35	Cat Anti Karat	M95	Kg	47.619,00	
36	Expansion Cap	M96	M2	8.058,60	
37	Polytene 125 mikron	M97	Kg	25.641,00	
38	Curing Compound	M98	Ltr	51.282,00	
39	Kayu Acuan	M99	M3	3.283.380,00	
40	Additive	M67a	Ltr	51.282,00	
41	Casing	M100	M2	11.988,00	
42	Pasir Talling		M3	344.988,00	
43	Polimer			59.940,00	
44	Batubara		kg	666,00	
45	Kerb jenis 1		Buah	59.940,00	
46	Kerb jenis 2		Buah	66.600,00	
47	Kerb jenis 3		Buah	73.260,00	
48	Bahan Modifikasi		Kg	99.900,00	
49	Aditif anti pengelupasan		Kg	39.960,00	
50	Bahan Pengisi (Filler) Tambahan		Kg	1.942,75	
51	Asbuton yang diproses		Kg	39.960,00	
52	Elastomer Alam		Kg	39.960,00	
53	Elastomer Sintesis		Kg	39.960,00	
54	Besi Pipa (Ex. Pertamina)	M52a	Kg	20.930,52	
55	Besi Plat Tebal 2 mm	M101a	M2	306.360,00	
56	Besi Plat Tebal 3,5 mm	M101b	M2	704.850,00	
57	Kayu Konstuksi Jembatan	M102	M3	5.185.476,00	
58	Baja Strip	M103	Batang	124.542,00	
59	Baut Jembatan	M104	Buah	7.326,00	
60	Plat Klem dan Baut		Buah	13.426,56	
61	Begel Gantungan Dia. 10 mm		Buah	16.650,00	
62	Sling Baru Dia. 1,5 " (isi baja)		M'	1.112.386,50	
63	Sling Baru Dia. 1 " (isi baja)		M'	783.369,18	



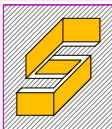

**PERENCANAAN GEOMETRIK DAN TEBAL PERKERASAN KAKU**  
**JALAN LINGKAR BARAT SP. SPORT CENTER - BUKIT SULAP**  
**KOTA LUBUKLINGGAU STA 00+000 - 08+150**  
**PROVINSI SUMATERA SELATAN**

**PEMBIMBING I**  
Mahmuda, S.T., M.T.  
NIP. 196207011989032002

**PEMBIMBING II**  
Drs. Bambang H. Fuady, S.T., M.M., M.T.  
NIP. 195807161986031004

**DIGAMBAR OLEH**  
Dwi Andra Octoni Darma  
NIM. 061940111879

**DIGAMBAR OLEH**  
Rangga Isminda  
NIM. 061940111891

**JUDUL GAMBAR**  
TRASE

**NO GAMBAR**  
1

**SKALA**  
1 : 25000

**POLITEKNIK**  
**NEGERI SRIWIJAYA**  
**PALEMBANG**

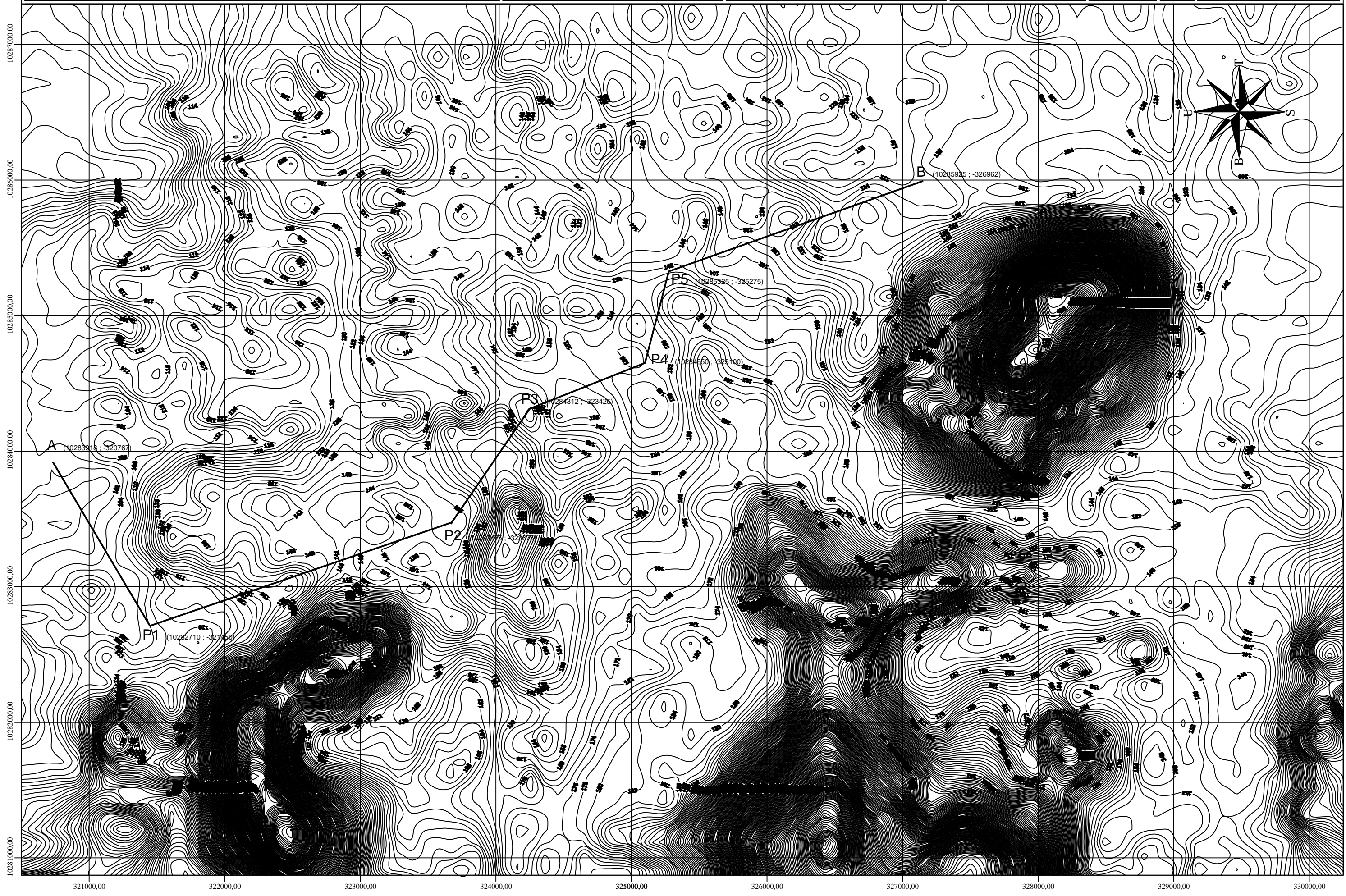



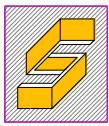

**PERENCANAAN GEOMETRIK DAN TEBAL PERKERASAN KAKU  
JALAN LINGKAR BARAT SP. *SPORT CENTER* - BUKIT SULAP  
KOTA LUBUKLINGGAU STA 00+000 - 08+150  
PROVINSI SUMATERA SELATAN**

PEMBIMBING I  
  
Mahmuda, S.T., M.T.  
NIP. 196207011989032002

PEMBIMBING II  
  
Drs. Bambang H. Fuady, S.T., M.M., M.T.  
NIP. 195807161986031004

DIGAMBAR OLEH :  
  
Dwi Andra Octami Darma  
NIS. 061940111879

Rangga Ismanda  
NIS. 061940111894

JUDUL GAMBAR  
  
PETA KONTUR TRASE

NOMOR GAMBAR  
  
JUMLAH GAMBAR

SKALA  
  
1 : 200  
1 : 1000

**POLITEKNIK  
NEGERI SRIWIJAYA  
PALEMBANG**

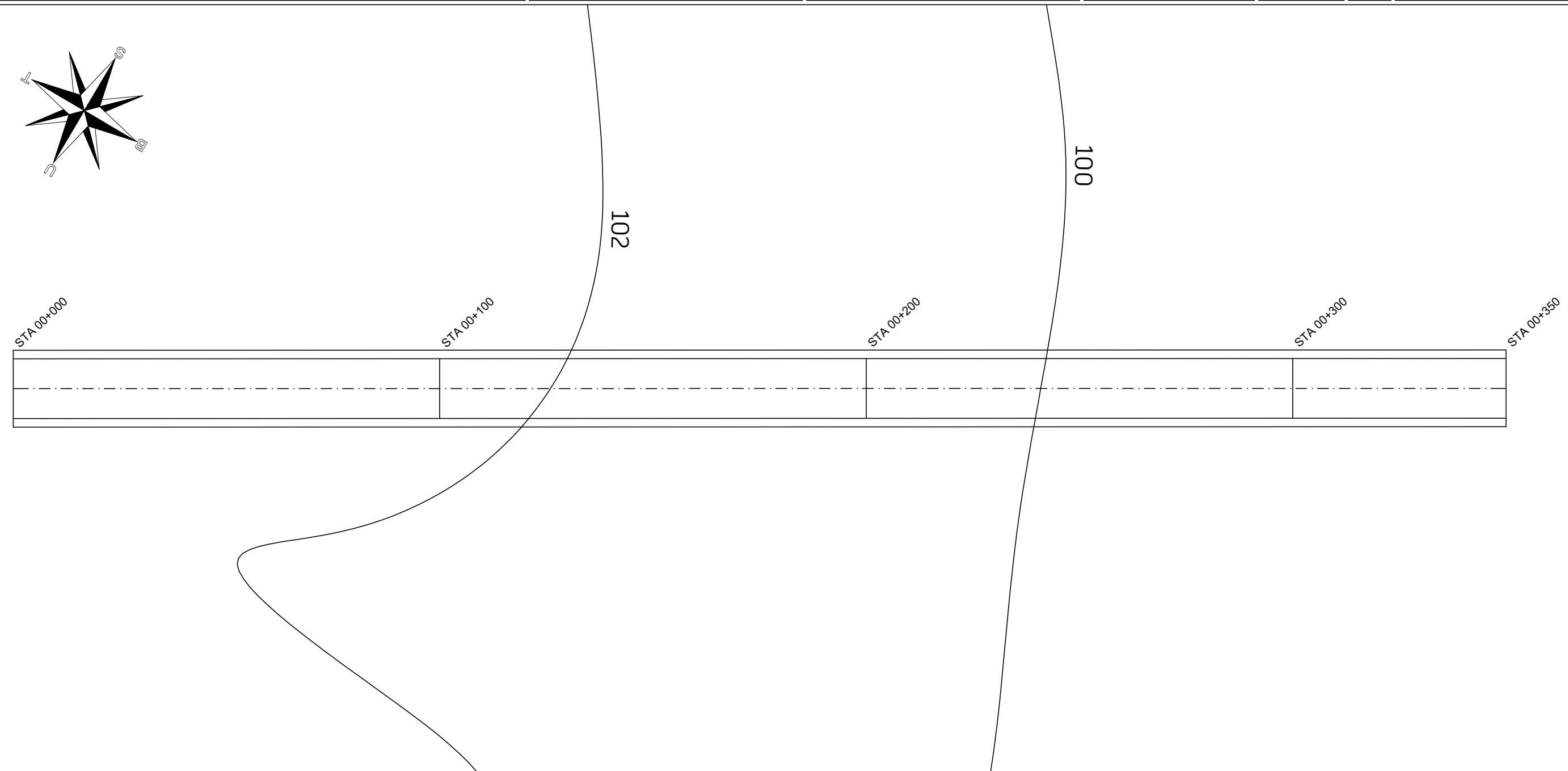
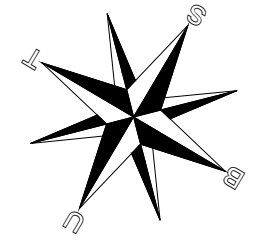

107						107
106						106
105						105
104						104
103						103
102						102
101						101
100						100
99						99
98						98
STA	00+000	00+100	00+200	00+300	00+350	STA
Elevasi Tanah Asli	103,271	102,226	100,768	99,126	99,585	Elevasi Tanah Asli
Elevasi Rencana	100,480	100,480	100,480	100,480	100,480	Elevasi Rencana

— MUKA TANAH ASLI

— DESAIN RENCANA

BOX CULVERT 016  
LENGKANG Ø10  
STA 00+300

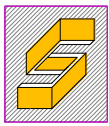

**PERENCANAAN GEOMETRIK DAN TEBAL PERKERASAN KAKU  
JALAN LINGKAR BARAT SP. *SPORT CENTER* - BUKIT SULAP  
KOTA LUBUKLINGGAU STA 00+000 - 08+150  
PROVINSI SUMATERA SELATAN**

PEMBIMBING I  Mahmuda, S.T., M.T. NIP. 196207011989032002	PEMBIMBING II  Drs. Bambang H. Fuady, S.T., M.M., M.T. NIP. 195807161986031004	DIGAMBAR OLEH :  Dwi Andra Octami Darma NIM. 061940111879		Rangga Ismanda NIM. 061940111894	JUDUL GAMBAR  PETA KONTUR TRASE	NOMOR GAMBAR  JUMLAH GAMBAR	SKALA  1 : 200 1 : 1000	<b>POLITEKNIK NEGERI SRIWIJAYA PALEMBANG</b>
--	---	--	--	-------------------------------------	---------------------------------------	-----------------------------------	----------------------------------	--

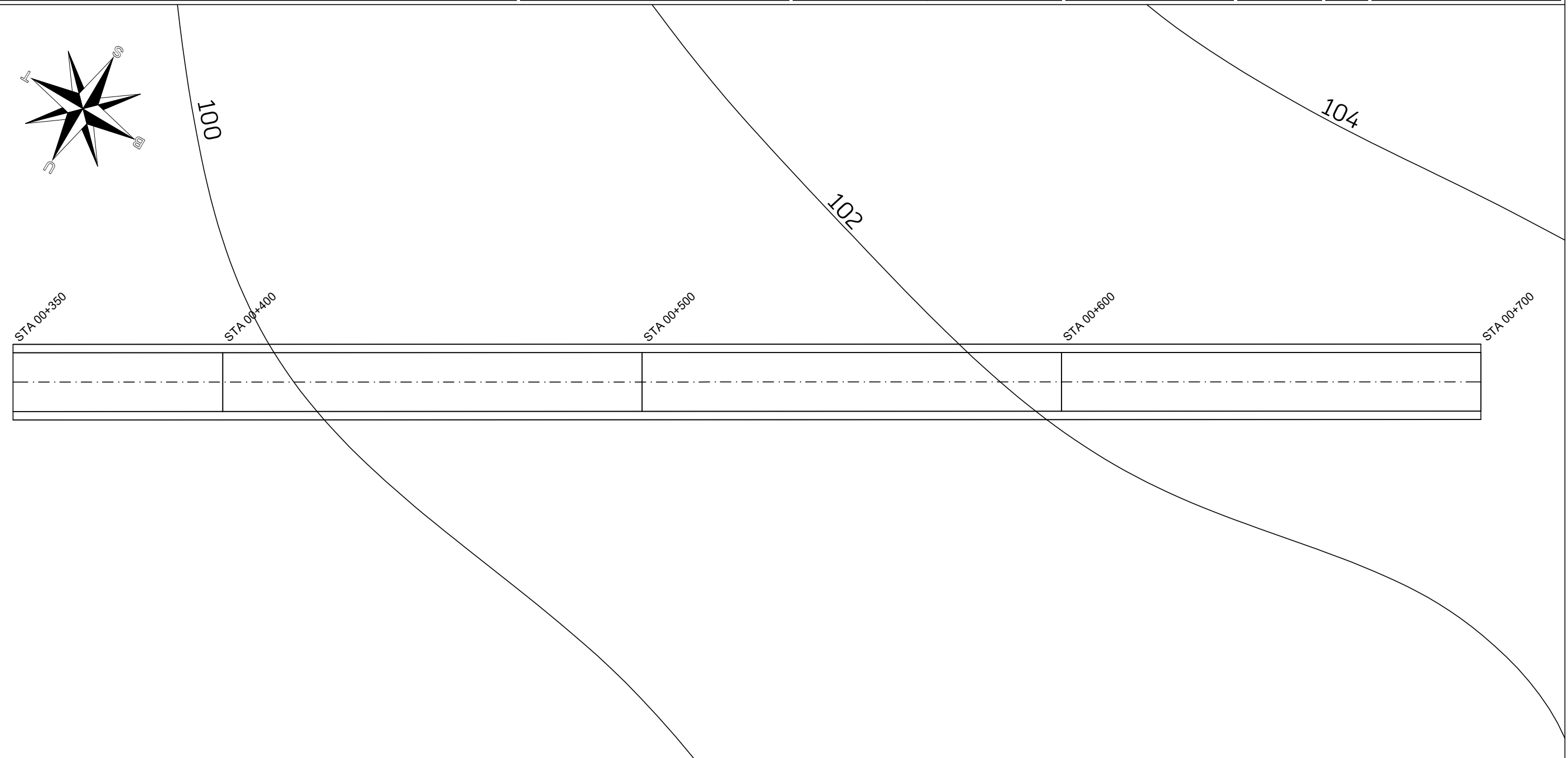
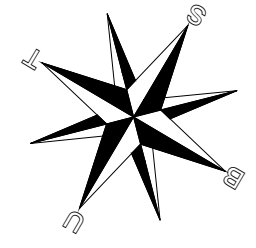

107						107
106						106
105						105
104						104
103						103
102						102
101						101
100						100
99						99
98						98
STA	00+350	00+400	00+500	00+600	00+700	STA
Elevasi Tanah Asli	99,585	99,686	100,890	102,194	103,137	Elevasi Tanah Asli
Elevasi Rencana	100,480	100,480	100,876	102,357	103,837	Elevasi Rencana

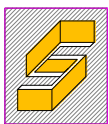

**PERENCANAAN GEOMETRIK DAN TEBAL PERKERASAN KAKU  
JALAN LINGKAR BARAT SP. *SPORT CENTER* - BUKIT SULAP  
KOTA LUBUKLINGGAU STA 00+000 - 08+150  
PROVINSI SUMATERA SELATAN**

PEMBIMBING I  
  
Mahmuda, S.T., M.T.  
NIP. 196207011989032002

PEMBIMBING II  
  
Drs. Bambang H. Fuady, S.T., M.M., M.T.  
NIP. 195807161986031004

DIGAMBAR OLEH :  
  
Dwi Andra Octami Darma  
NIM. 061940111879

Rangga Ismanda  
NIM. 061940111894

JUDUL GAMBAR  
  
PETA KONTUR TRASE

NOMOR GAMBAR  
  
JUMLAH GAMBAR

SKALA  
  
1 : 200  
1 : 1000

**POLITEKNIK  
NEGERI SRIWIJAYA  
PALEMBANG**

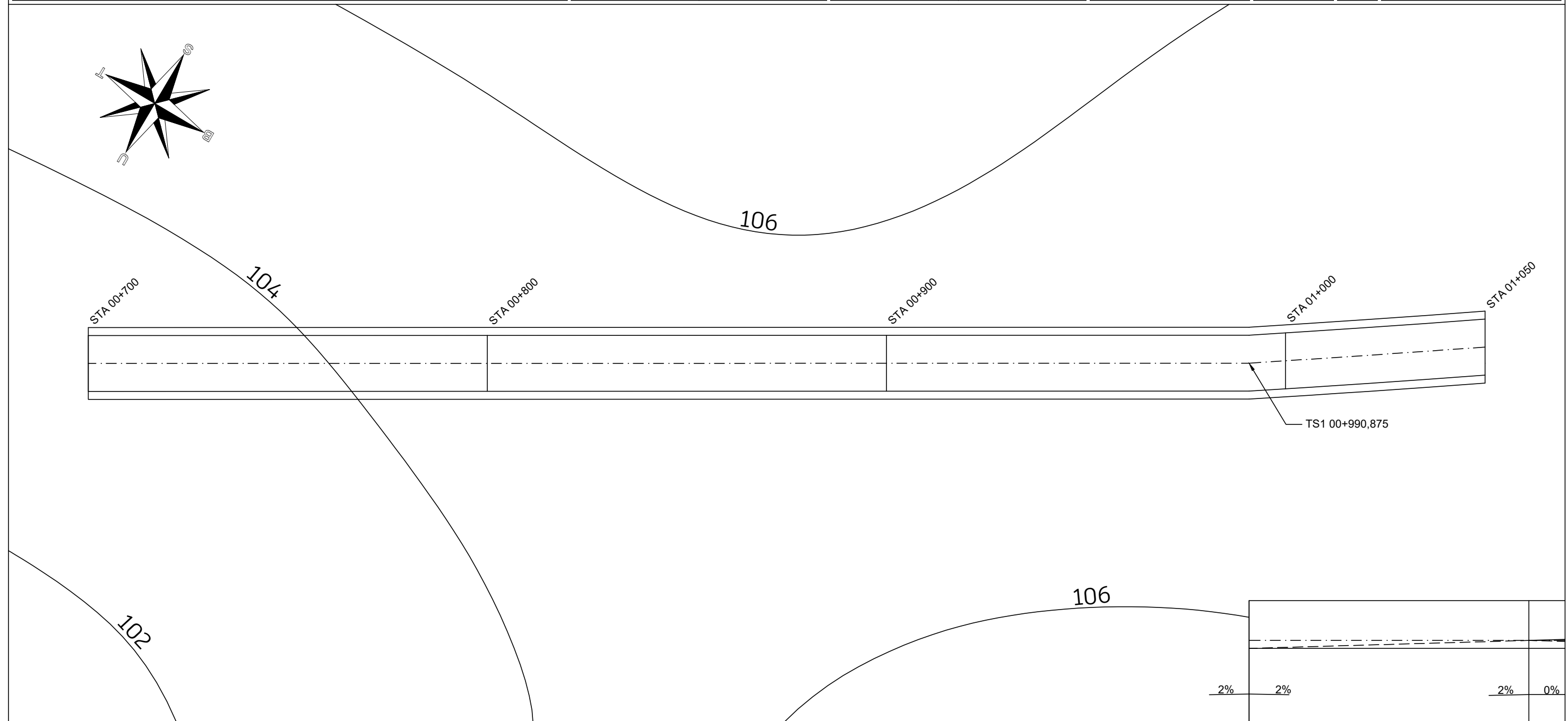

109							109
108							108
107							107
106							106
105							105
104							104
103							103
102							102
101							101
100							100
STA	00+700	00+800	00+900		01+000	01+050	STA
Elevasi Tanah Asli	103,137	104,893	106,000		106,000	106,000	Elevasi Tanah Asli
Elevasi Rencana	103,837	105,318	106,552		106,566	106,566	Elevasi Rencana



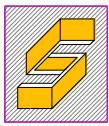

**PERENCANAAN GEOMETRIK DAN TEBAL PERKERASAN KAKU**  
**JALAN LINGKAR BARAT SP. SPORT CENTER - BUKIT SULAP**  
**KOTA LUBUKLINGGAU STA 00+000 - 08+150**  
**PROVINSI SUMATERA SELATAN**

PEMBIMBING I  Mahmuda, S.T., M.T. NIP. 196207011989032002	PEMBIMBING II  Drs. Bambang H. Fuady, S.T., M.M., M.T. NIP. 195807161986031004	DIGAMBAR OLEH :  Dwi Andra Octami Darma NIS. 061940111879		Rangga Ismanda NIS. 061940111894	JUDUL GAMBAR  PETA KONTUR TRASE	NOMOR GAMBAR  JUMLAH GAMBAR	SKALA  1 : 200 1 : 1000	<b>POLITEKNIK</b> <b>NEGERI SRIWIJAYA</b> <b>PALEMBANG</b>
--	---	--	--	-------------------------------------	---------------------------------------	-----------------------------------	----------------------------------	--

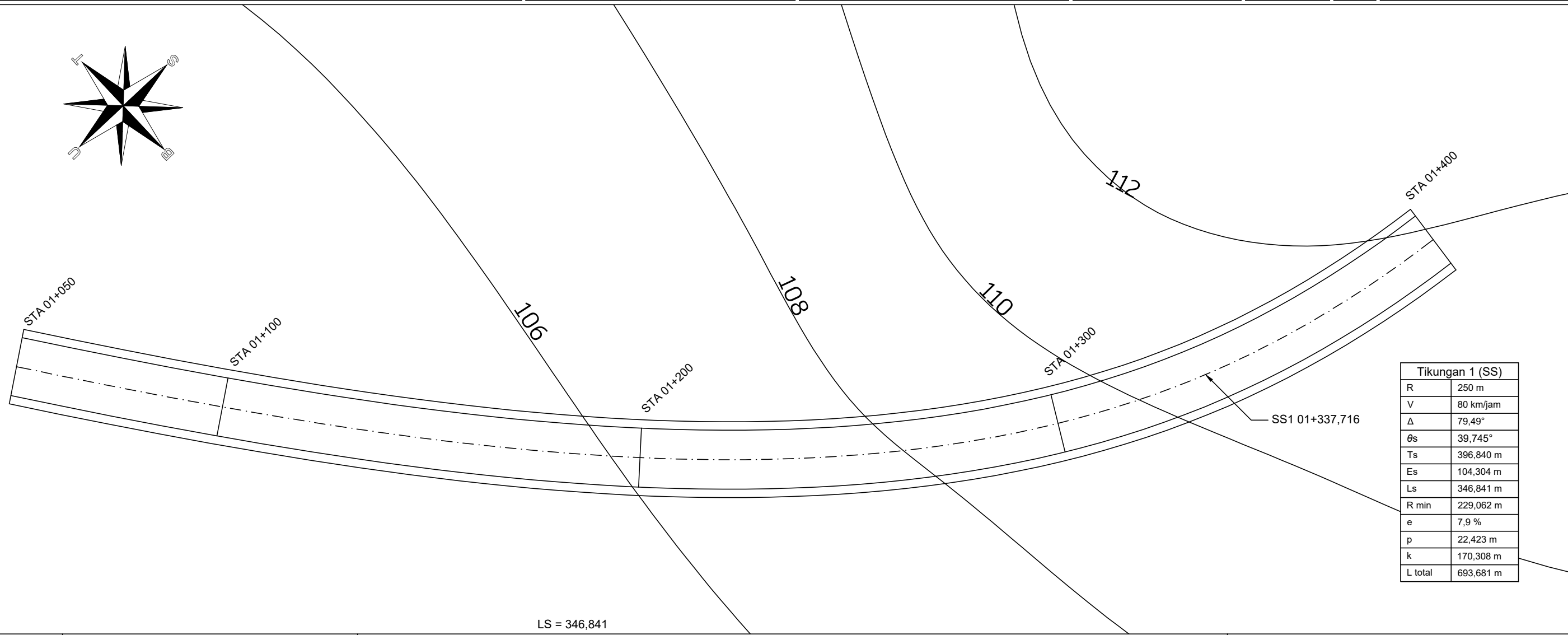
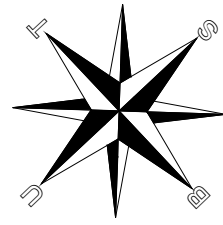

R	250 m
V	80 km/jam
Δ	79,49°
θs	39,745°
Ts	396,840 m
Es	104,304 m
Ls	346,841 m
R min	229,062 m
e	7,9 %
p	22,423 m
k	170,308 m
L total	693,681 m

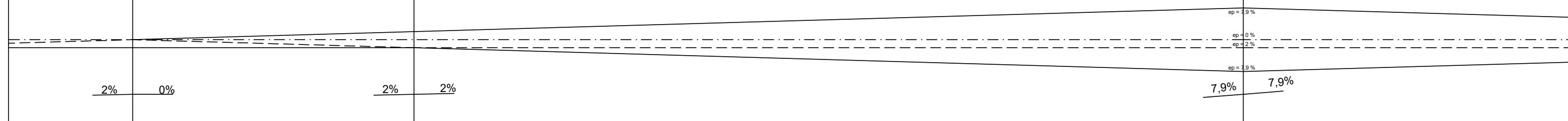

114						114
113						113
112						112
111						111
110						110
109						109
108						108
107						107
106						106
105						105
STA	01+050	01+100	01+200	01+300	01+400	STA
Elevasi Tanah Asli	106,000	106,000	106,185	109,423	111,952	Elevasi Tanah Asli
Elevasi Rencana	106,566	106,566	107,531	109,911	112,292	Elevasi Rencana

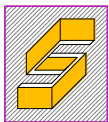

**PERENCANAAN GEOMETRIK DAN TEBAL PERKERASAN KAKU**  
**JALAN LINGKAR BARAT SP. SPORT CENTER - BUKIT SULAP**  
**KOTA LUBUKLINGGAU STA 00+000 - 08+150**  
**PROVINSI SUMATERA SELATAN**

PEMBIMBING I  
 Mahmuda, S.T., M.T.  
 NIP. 196207011989032002

PEMBIMBING II  
 Drs. Bambang H. Fuady, S.T., M.M., M.T.  
 NIP. 195807161986031004

DIGAMBAR OLEH :  
 Dwi Andra Octami Darma  
 NIM. 061940111879

Rangga Ismanda  
 NIM. 061940111894

JUDUL GAMBAR  
 PETA KONTUR TRASE

NOMOR GAMBAR  
 JUMLAH GAMBAR

SKALA  
 1 : 200  
 1 : 1000

**POLITEKNIK**  
**NEGERI SRIWIJAYA**  
**PALEMBANG**

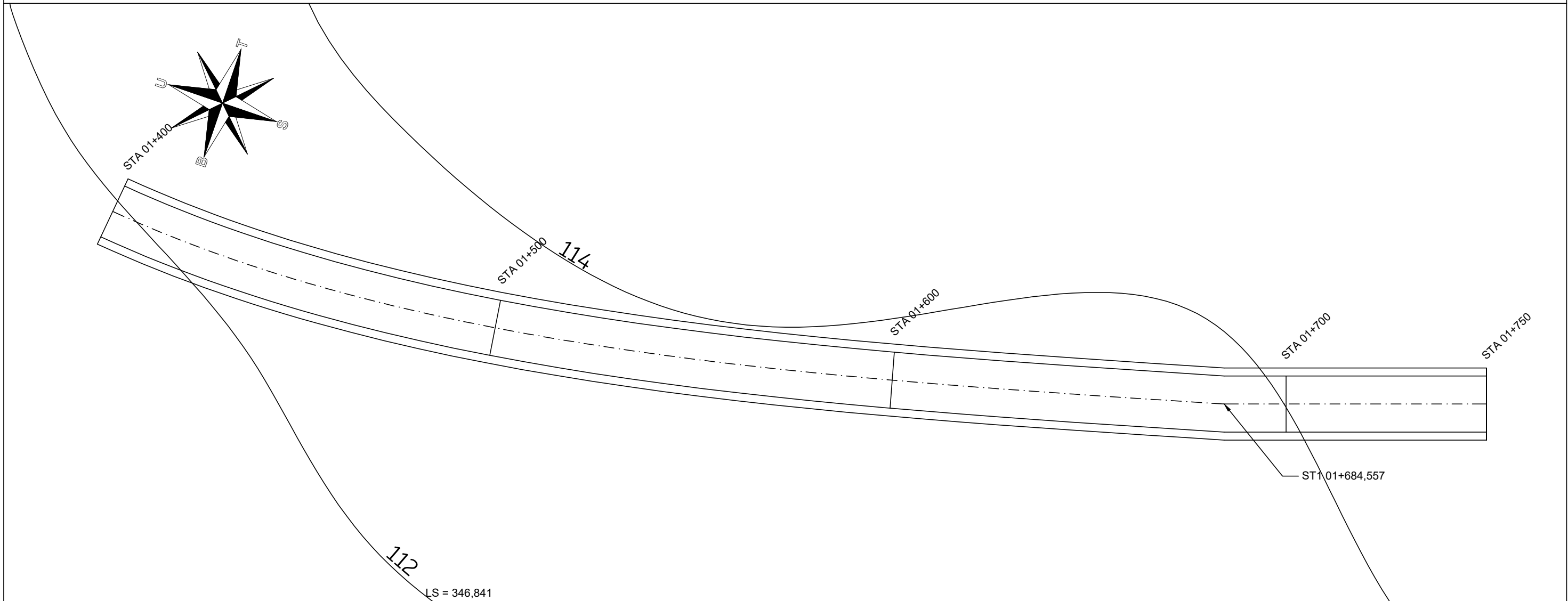

		2%		2%		2%		0%		2%		2%	
118													118
117													117
116													116
115													115
114													114
113													113
112													112
111													111
110													110
109													109
STA	01+400		01+500			01+600		01+700		01+750			STA
Elevasi Tanah Asli	111,952		113,468			113,700		114,000		114,485			Elevasi Tanah Asli
Elevasi Rencana	112,292		113,875			113,875		113,875		114,563			Elevasi Rencana

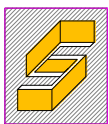

**PERENCANAAN GEOMETRIK DAN TEBAL PERKERASAN KAKU  
JALAN LINGKAR BARAT SP. *SPORT CENTER* - BUKIT SULAP  
KOTA LUBUKLINGGAU STA 00+000 - 08+150  
PROVINSI SUMATERA SELATAN**

PEMBIMBING I  
  
Mahmuda, S.T., M.T.  
NIP. 196207011989032002

PEMBIMBING II  
  
Drs. Bambang H. Fuady, S.T., M.M., M.T.  
NIP. 195807161986031004

DIGAMBAR OLEH :  
  
Dwi Andra Octami Darma  
NISL. 061940111879

Rangga Ismunda  
NISL. 061940111894

JUDUL GAMBAR  
  
PETA KONTUR TRASE

NOMOR GAMBAR  
  
JUMLAH GAMBAR

SKALA  
  
1 : 200  
1 : 1000

**POLITEKNIK  
NEGERI SRIWIJAYA  
PALEMBANG**

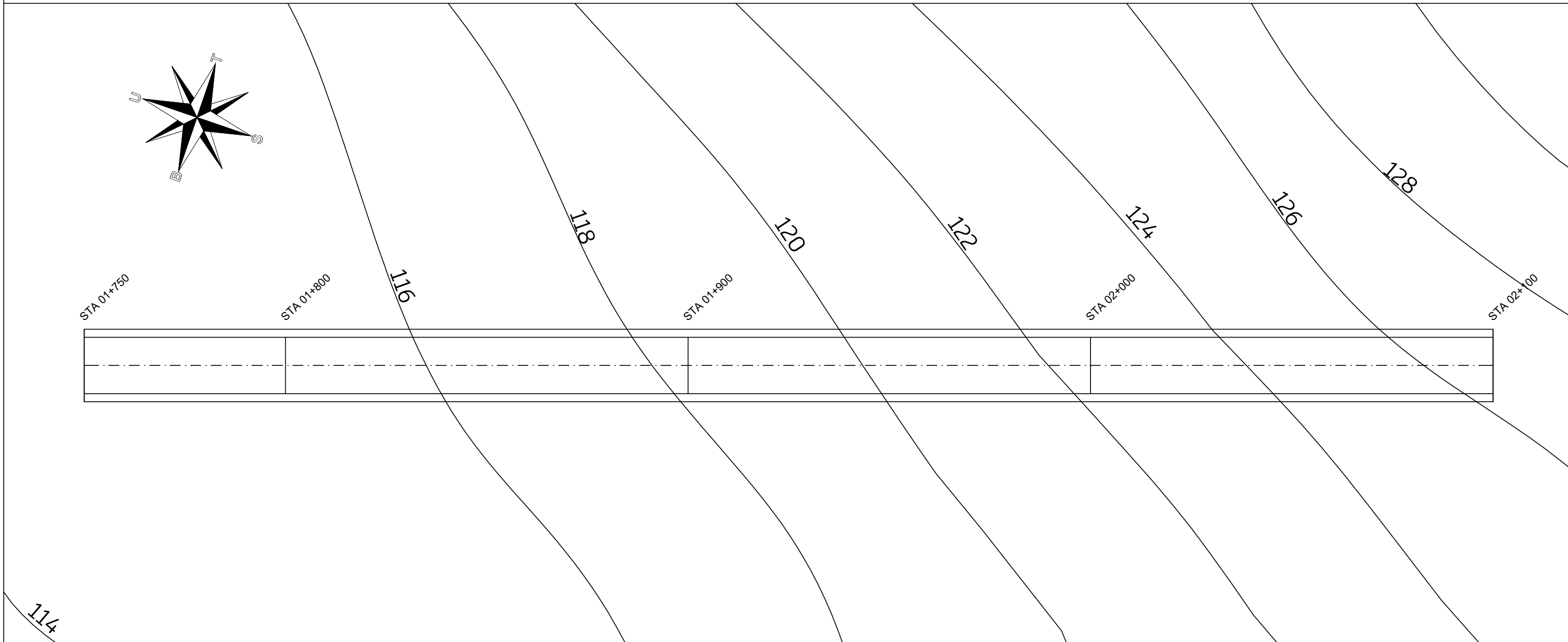

127						127
126						126
125						125
124						124
123						123
122						122
121						121
120						120
119						119
118						118
117						117
116						116
115						115
114						114
STA	01+750	01+800	01+900	02+000	02+100	STA
Elevasi Tanah Asli	114,485	114,970	118,323	122,445	126,643	Elevasi Tanah Asli
Elevasi Rencana	114,563	115,250	119,948	122,765	126,582	Elevasi Rencana

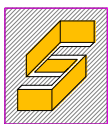

**PERENCANAAN GEOMETRIK DAN TEBAL PERKERASAN KAKU  
JALAN LINGKAR BARAT SP. *SPORT CENTER* - BUKIT SULAP  
KOTA LUBUKLINGGAU STA 00+000 - 08+150  
PROVINSI SUMATERA SELATAN**

PEMBIMBING I  
  
Mahmuda, S.T., M.T.  
NIP. 196207011989032002

PEMBIMBING II  
  
Drs. Bambang H. Fuady, S.T., M.M., M.T.  
NIP. 195807161986031004

DIGAMBAR OLEH :  
  
Dwi Andra Octami Darma  
NISL. 061940111879

Rangga Ismanda  
NEM. 061940111894

JUDUL GAMBAR  
  
PETA KONTUR TRASE

NOMOR GAMBAR  
  
JUMLAH GAMBAR

SKALA  
  
1 : 200  
1 : 1000

**POLITEKNIK  
NEGERI SRIWIJAYA  
PALEMBANG**

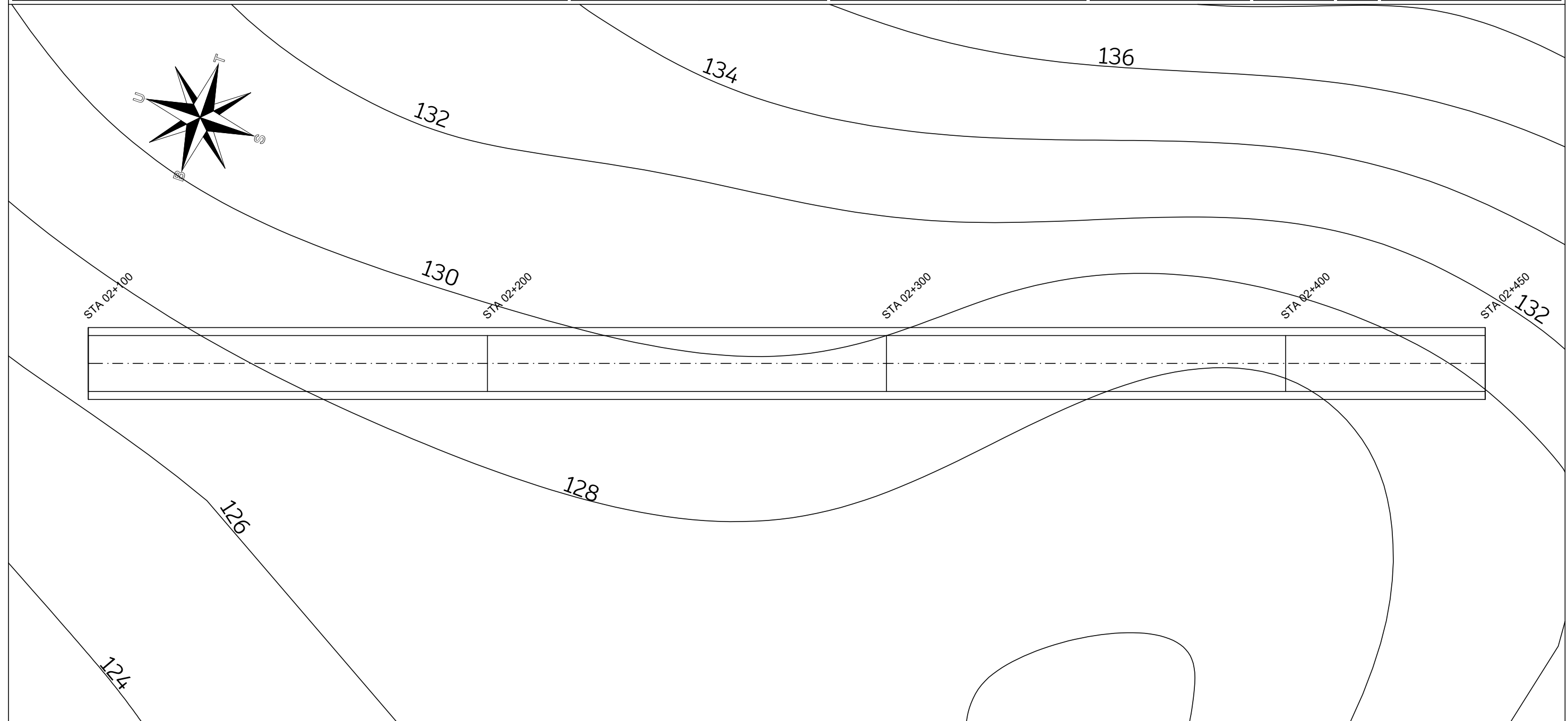

134						134
133						133
132						132
131						131
130						130
129						129
128						128
127						127
126						126
125						125
STA	02+100	02+200	02+300	02+400	02+450	STA
Elevasi Tanah Asli	126,643	129,274	129,660	128,122	130,933	Elevasi Tanah Asli
Elevasi Rencana	126,582	129,366	129,498	130,790	132,722	Elevasi Rencana



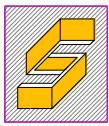

**PERENCANAAN GEOMETRIK DAN TEBAL PERKERASAN KAKU  
JALAN LINGKAR BARAT SP. *SPORT CENTER* - BUKIT SULAP  
KOTA LUBUKLINGGAU STA 00+000 - 08+150  
PROVINSI SUMATERA SELATAN**

PEMBIMBING I  
  
Mahmuda, S.T., M.T.  
NIP. 196207011989032002

PEMBIMBING II  
  
Drs. Bambang H. Fuady, S.T., M.M., M.T.  
NIP. 195807161986031004

DIGAMBAR OLEH :  
  
Dwi Andra Octami Darma  
NISL. 061940111879

Rangga Ismanda  
NEM. 061940111894

JUDUL GAMBAR  
  
PETA KONTUR TRASE

NOMOR GAMBAR  
  
JUMLAH GAMBAR

SKALA  
  
1 : 200  
1 : 1000

**POLITEKNIK  
NEGERI SRIWIJAYA  
PALEMBANG**

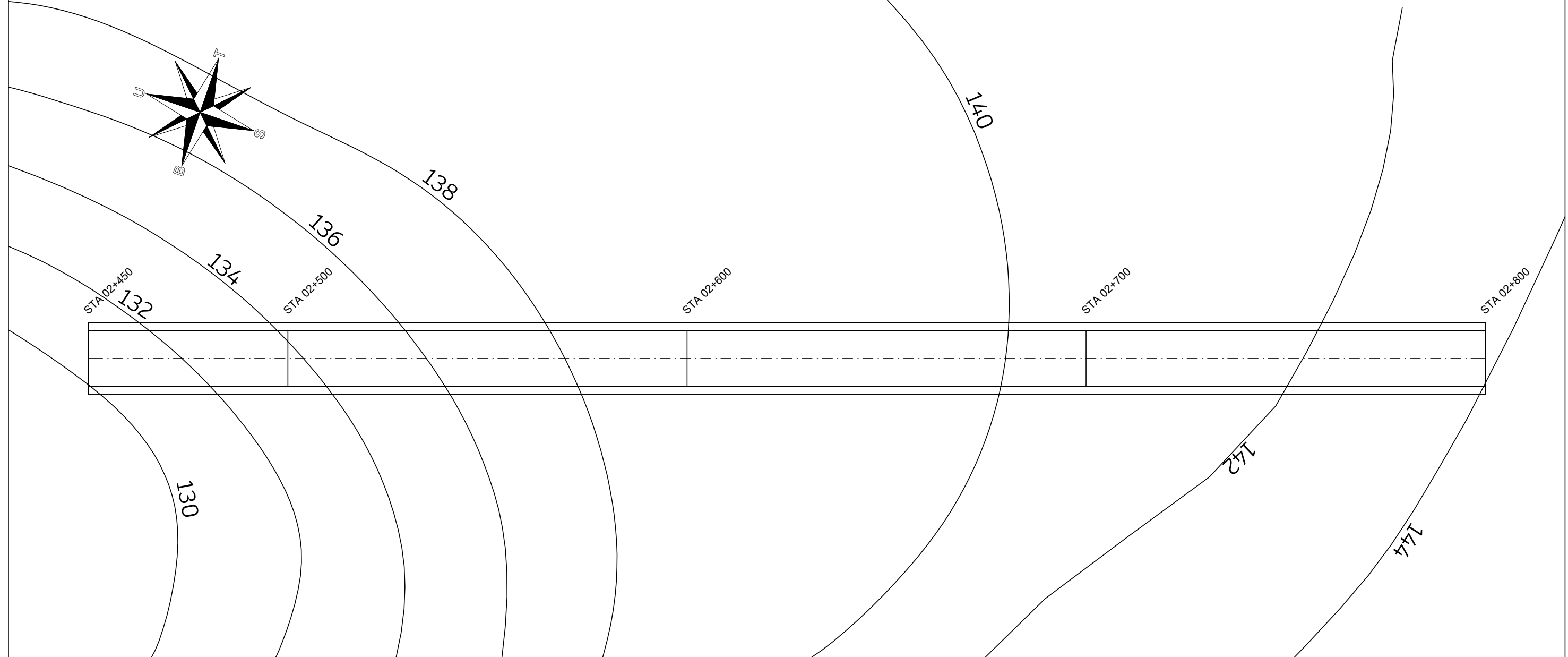

144						144
143						143
142						142
141						141
140						140
139						139
138						138
137						137
136						136
135						135
134						134
133						133
132						132
STA	02+450	02+500	02+600	02+700	02+800	STA
Elevasi Tanah Asli	130,933	133,743	140,000	142,000	143,871	Elevasi Tanah Asli
Elevasi Rencana	132,722	134,653	138,689	142,688	144,281	Elevasi Rencana

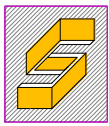

**PERENCANAAN GEOMETRIK DAN TEBAL PERKERASAN KAKU  
JALAN LINGKAR BARAT SP. *SPORT CENTER* - BUKIT SULAP  
KOTA LUBUKLINGGAU STA 00+000 - 08+150  
PROVINSI SUMATERA SELATAN**

PEMBIMBING I  
**Mahmuda, S.T., M.T.**  
NIP. 196207011989032002

PEMBIMBING II  
**Drs. Bambang H. Fuady, S.T., M.M., M.T.**  
NIP. 195807161986031004

DIGAMBAR OLEH :  
**Dwi Andra Octami Darma**  
NISL. 061940111879

**Rangga Ismanda**  
NISL. 061940111894

JUDUL GAMBAR  
PETA KONTUR TRASE

NOMOR GAMBAR  
JUMLAH GAMBAR

SKALA  
1 : 200  
1 : 1000

**POLITEKNIK  
NEGERI SRIWIJAYA  
PALEMBANG**

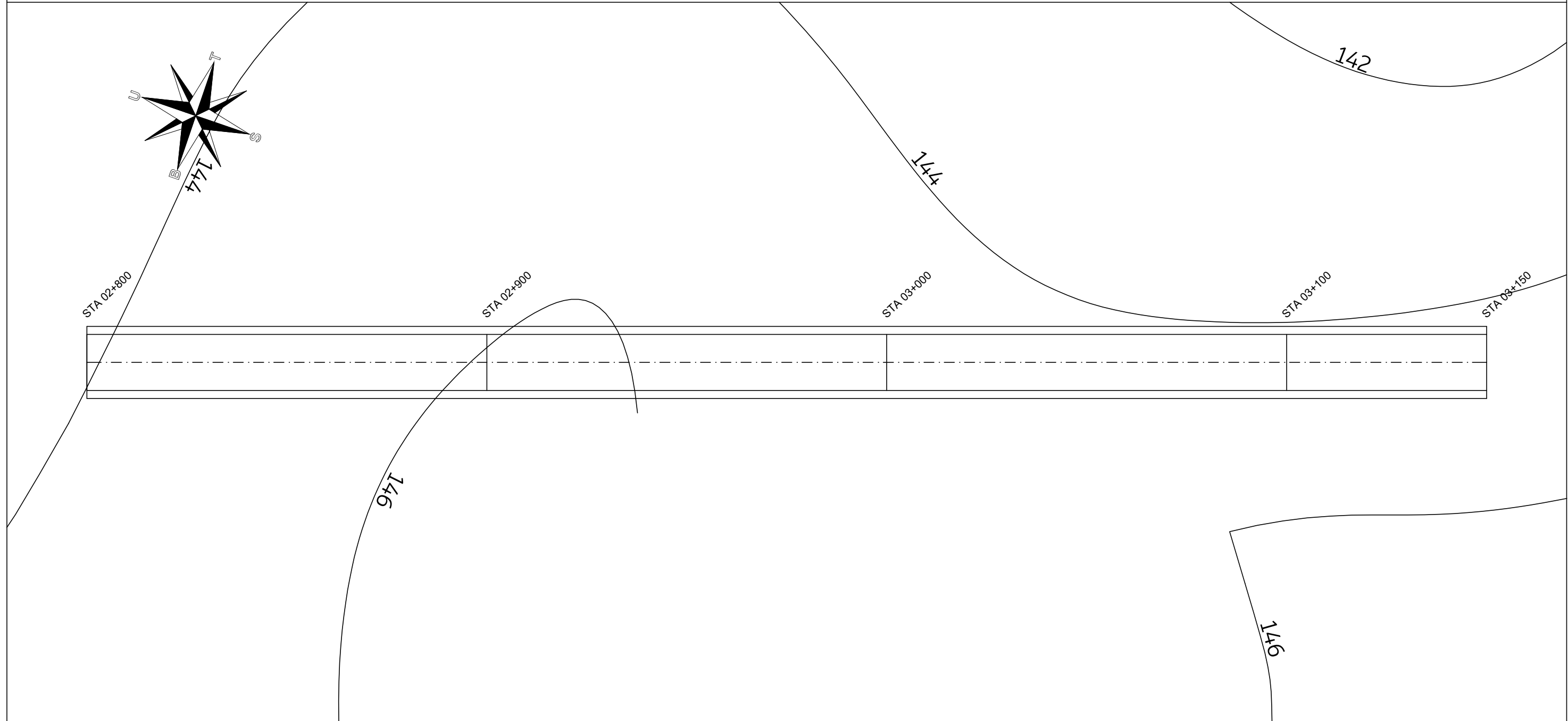

148						148
147						147
146						146
145						145
144						144
143						143
142						142
141						141
140						140
139						139
STA	02+800	02+900	03+000	03+100	03+150	STA
Elevasi Tanah Asli	143,871	146,000	144,000	144,404	144,794	Elevasi Tanah Asli
Elevasi Rencana	144,281	144,281	144,281	144,596	145,131	Elevasi Rencana

— MUKA TANAH ASLI

— DESAIN RENCANA

BOX CULVERT Ø16  
SENGKANG Ø10  
STA 03+000

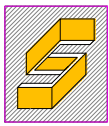

**PERENCANAAN GEOMETRIK DAN TEBAL PERKERASAN KAKU  
JALAN LINGKAR BARAT SP. *SPORT CENTER* - BUKIT SULAP  
KOTA LUBUKLINGGAU STA 00+000 - 08+150  
PROVINSI SUMATERA SELATAN**

PEMBIMBING I  Mahmuda, S.T., M.T. NIP. 196207011989032002	PEMBIMBING II  Drs. Bambang H. Fuady, S.T., M.M., M.T. NIP. 195807161986031004	DIGAMBAR OLEH :  Dwi Andra Octami Darma NIS. 061940111879		Rangga Isnanda NIS. 061940111894	JUDUL GAMBAR  PETA KONTUR TRASE	NOMOR GAMBAR  JUMLAH GAMBAR	SKALA  1 : 200 1 : 1000	<b>POLITEKNIK NEGERI SRIWIJAYA PALEMBANG</b>
--	---	--	--	-------------------------------------	---------------------------------------	-----------------------------------	----------------------------------	--

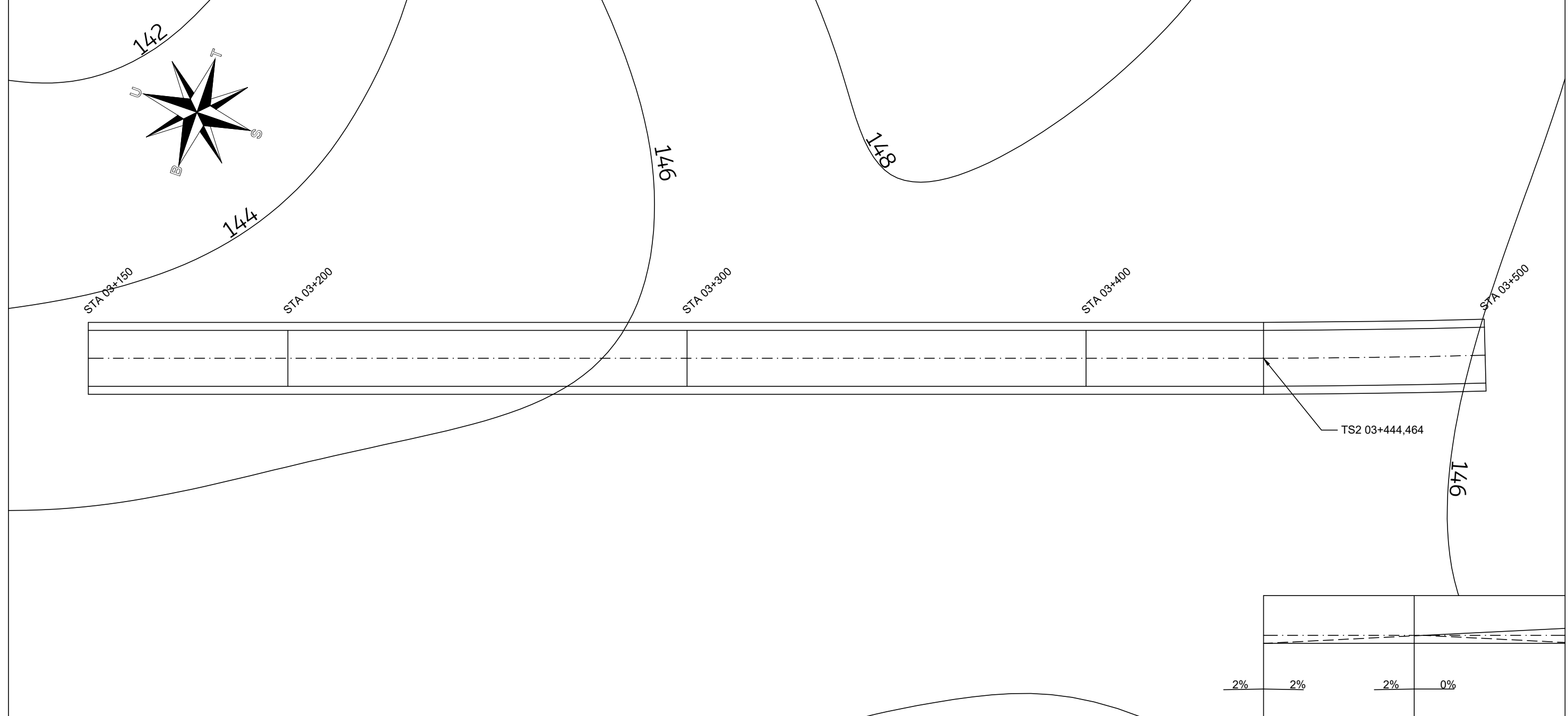

152						152
151						151
150						150
149						149
148						148
147						147
146						146
145						145
144						144
143						143
STA	03+150	03+200	03+300	03+400	03+500	STA
Elevasi Tanah Asli	144,794	145,183	146,424	148,000	146,000	Elevasi Tanah Asli
Elevasi Rencana	145,131	145,666	146,736	147,580	147,584	Elevasi Rencana

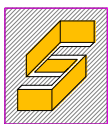

**PERENCANAAN GEOMETRIK DAN TEBAL PERKERASAN KAKU  
JALAN LINGKAR BARAT SP. *SPORT CENTER* - BUKIT SULAP  
KOTA LUBUKLINGGAU STA 00+000 - 08+150  
PROVINSI SUMATERA SELATAN**

PEMBIMBING I  Mahmuda, S.T., M.T. NIP. 196207011989032002	PEMBIMBING II  Drs. Bambang H. Fuady, S.T., M.M., M.T. NIP. 195807161986031004	DIGAMBAR OLEH :  Dwi Andra Octami Darma NIM. 061940111879		Rangga Ismanda NIM. 061940111894	JUDUL GAMBAR  PETA KONTUR TRASE	NOMOR GAMBAR  JUMLAH GAMBAR	SKALA  1 : 200 1 : 1000	<b>POLITEKNIK NEGERI SRIWIJAYA PALEMBANG</b>
--	---	--	--	-------------------------------------	---------------------------------------	-----------------------------------	----------------------------------	--

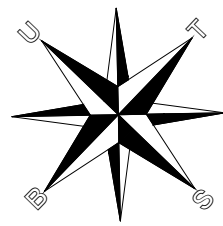

R	300 m
V	80 km/jam
Δ	36,54°
θs	18,27°
Ts	196,091 m
Es	21,415 m
Ls	191,323 m
R min	229,062 m
e	7,55 %
p	5,213 m
k	95,329 m
L total	382,646 m

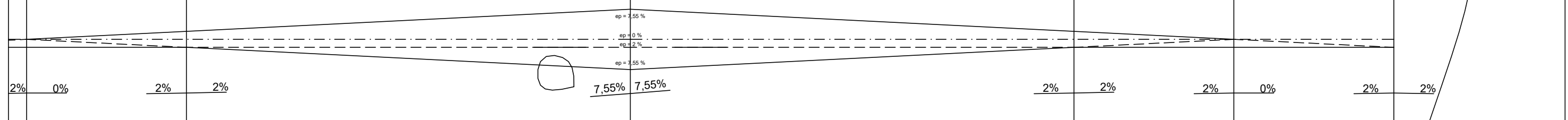
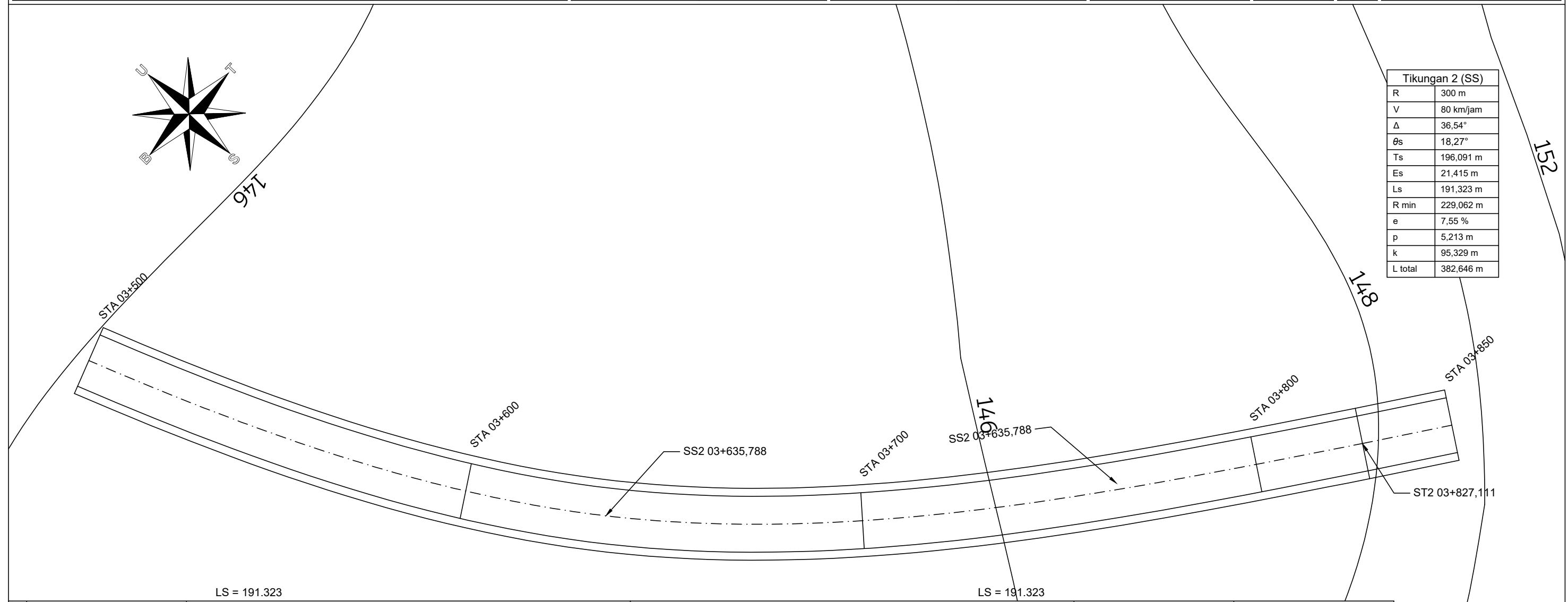

153								153
152								152
151								151
150								150
149								149
148								148
147								147
146								146
145								145
144								144
STA	03+500	03+600	03+700	03+800	03+850	STA		
Elevasi Tanah Asli	146,000	146,000	146,000	148,000	150,796	Elevasi Tanah Asli		
Elevasi Rencana	147,584	147,584	147,584	148,886	151,563	Elevasi Rencana		



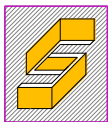

**PERENCANAAN GEOMETRIK DAN TEBAL PERKERASAN KAKU  
JALAN LINGKAR BARAT SP. SPORT CENTER - BUKIT SULAP  
KOTA LUBUKLINGGAU STA 00+000 - 08+150  
PROVINSI SUMATERA SELATAN**

PEMBIMBING I  
  
Mahmuda, S.T., M.T.  
NIP. 196207011989032002

PEMBIMBING II  
  
Drs. Bambang H. Fuady, S.T., M.M., M.T.  
NIP. 195807161986031004

DIGAMBAR OLEH :  
  
Dwi Andra Octami Darma  
NIS. 061940111879  
  
Rangga Ismanda  
NIS. 061940111894

JUDUL GAMBAR  
  
PETA KONTUR TRASE

NOMOR GAMBAR  
  
JUMLAH GAMBAR

SKALA  
  
1 : 200  
1 : 1000

**POLITEKNIK  
NEGERI SRIWIJAYA  
PALEMBANG**

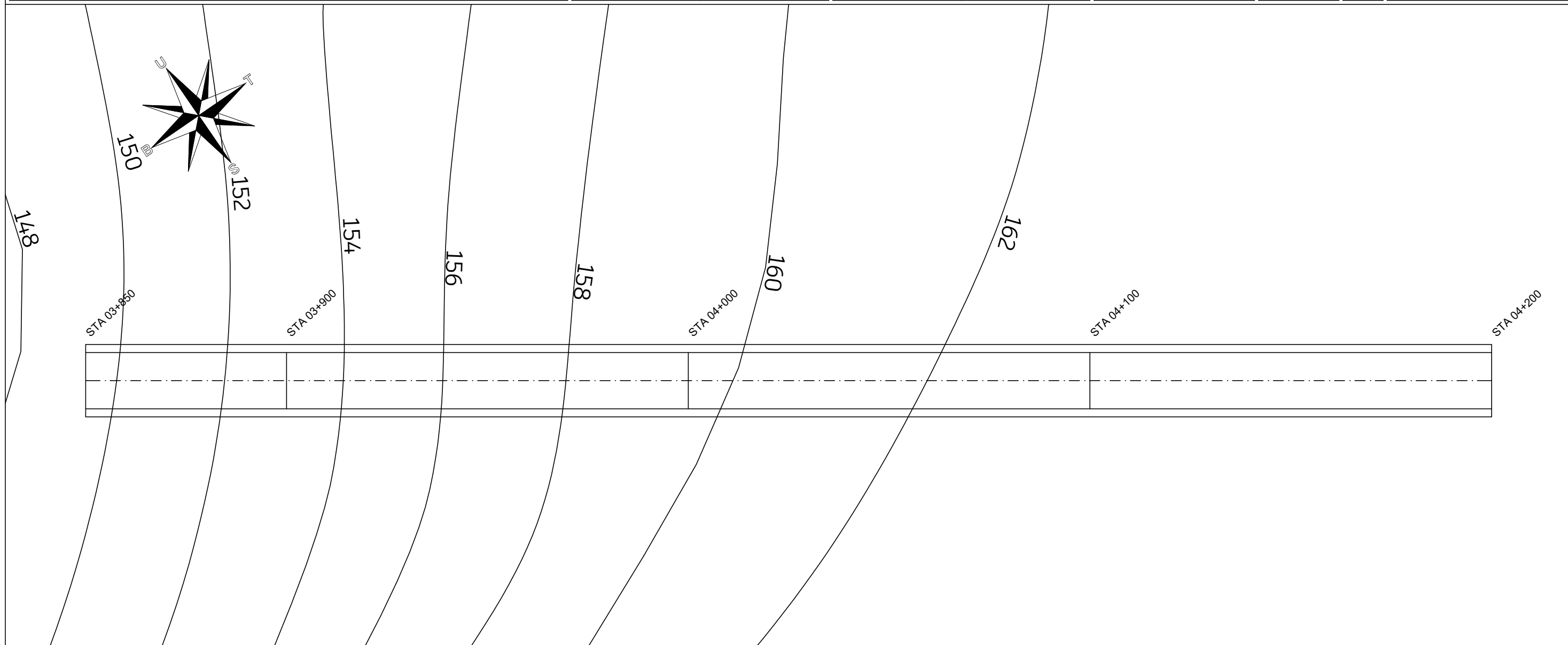

164						164
163						163
162						162
161						161
160						160
159						159
158						158
157						157
156						156
155						155
154						154
153						153
152						152
151						151
STA	03+850	03+900	04+000	04+100	04+200	STA
Elevasi Tanah Asli	150,796	153,592	159,742	164,169	162,000	Elevasi Tanah Asli
Elevasi Rencana	151,563	153,239	158,217	161,225	161,384	Elevasi Rencana

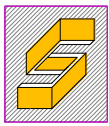

**PERENCANAAN GEOMETRIK DAN TEBAL PERKERASAN KAKU  
JALAN LINGKAR BARAT SP. *SPORT CENTER* - BUKIT SULAP  
KOTA LUBUKLINGGAU STA 00+000 - 08+150  
PROVINSI SUMATERA SELATAN**

PEMBIMBING I  Mahmuda, S.T., M.T. NIP. 196207011989032002	PEMBIMBING II  Drs. Bambang H. Fuady, S.T., M.M., M.T. NIP. 195807161986031004	DIGAMBAR OLEH :  Dwi Andra Octoni Darma NIM. 061940111879		Rangga Ismanda NIM. 061940111894	JUDUL GAMBAR  PETA KONTUR TRASE	NOMOR GAMBAR  JUMLAH GAMBAR	SKALA  1 : 200 1 : 1000	<b>POLITEKNIK NEGERI SRIWIJAYA PALEMBANG</b>
--	---	--	--	-------------------------------------	---------------------------------------	-----------------------------------	----------------------------------	--

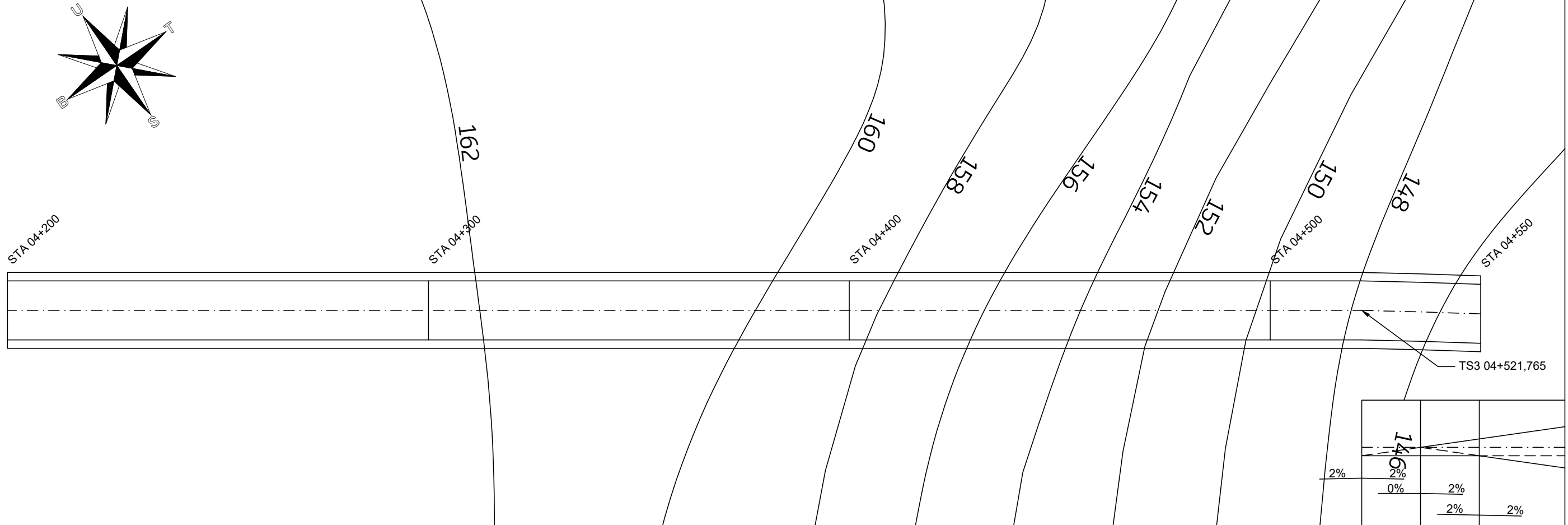

162						162
161						161
160						160
159						159
158						158
157						157
156						156
155						155
154						154
153						153
152						152
151						151
150						150
149						149
148						148
147						147
146						146
STA	04+200	04+300	04+400	04+500	04+550	STA
Elevasi Tanah Asli	162,000	162,000	158,661	149,622	146,853	Elevasi Tanah Asli
Elevasi Rencana	161,384	160,352	156,740	153,006	151,500	Elevasi Rencana

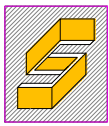

**PERENCANAAN GEOMETRIK DAN TEBAL PERKERASAN KAKU**  
**JALAN LINGKAR BARAT SP. SPORT CENTER - BUKIT SULAP**  
**KOTA LUBUKLINGGAU STA 00+000 - 08+150**  
**PROVINSI SUMATERA SELATAN**

PEMBIMBING I <small>Mahmuda, S.T., M.T. NIP. 196207011989032002</small>	PEMBIMBING II <small>Drs. Bambang H. Fuady, S.T., M.M., M.T. NIP. 195807161986031004</small>	DIGAMBAR OLEH : <small>Dwi Andra Octami Darma NIM. 061940111879</small> <small>Rangga Isnanda NIM. 061940111891</small>		JUDUL GAMBAR PETA KONTUR TRASE	NOMOR GAMBAR JUMLAH GAMBAR	SKALA 1 : 200 1 : 1000	<b>POLITEKNIK</b> <b>NEGERI SRIWIJAYA</b> <b>PALEMBANG</b>
--	---	---	--	-----------------------------------	-------------------------------	------------------------------	--

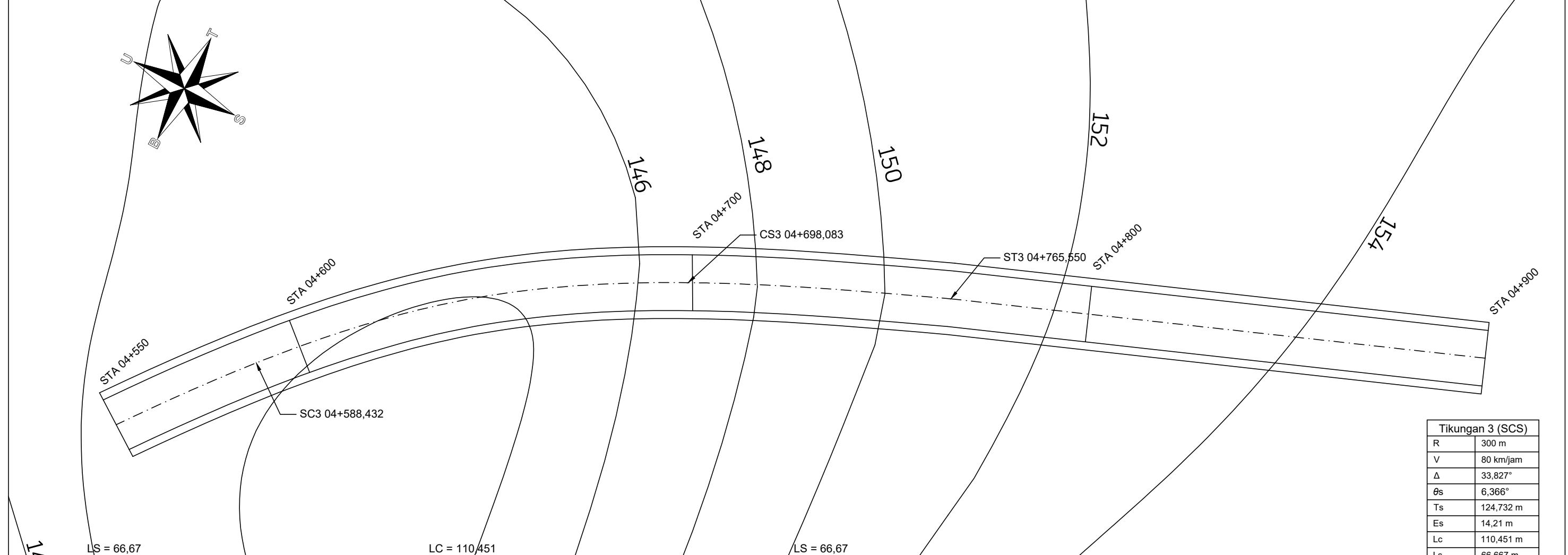

Tikungan 3 (SCS)	
R	300 m
V	80 km/jam
Δ	33,827°
θs	6,366°
Ts	124,732 m
Es	14,21 m
Lc	110,451 m
Ls	66,667 m
R min	229,062 m
e	7,55 %
p	0,619 m
k	33,320 m
Xs	2,469 m
Ys	2,469 m

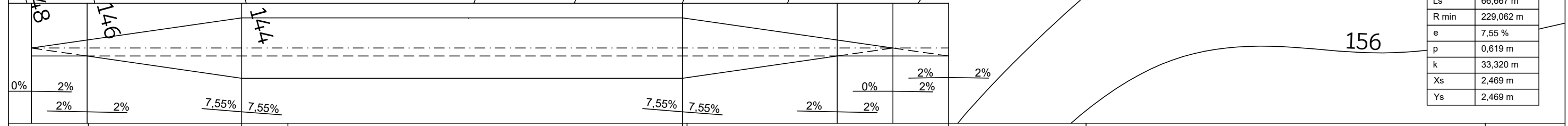

155							155
154							154
153							153
152							152
151							151
150							150
149							149
148							148
147							147
146							146
145							145
144							144
STA	04+550	04+600	04+700	04+800	04+900	STA	
Elevasi Tanah Asli	146,853	144,084	147,000	151,753	155,211	Elevasi Tanah Asli	
Elevasi Rencana	151,500	150,002	150,071	151,287	152,498	Elevasi Rencana	



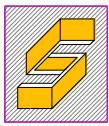

**PERENCANAAN GEOMETRIK DAN TEBAL PERKERASAN KAKU  
JALAN LINGKAR BARAT SP. *SPORT CENTER* - BUKIT SULAP  
KOTA LUBUKLINGGAU STA 00+000 - 08+150  
PROVINSI SUMATERA SELATAN**

PEMBIMBING I  
  
Mahmuda, S.T., M.T.  
NIP. 196207011989032002

PEMBIMBING II  
  
Drs. Bambang H. Fuady, S.T., M.M., M.T.  
NIP. 195807161986031004

DIGAMBAR OLEH :  
  
Dwi Andra Octoni Darma  
NIS. 061940111879

Rangga Isminda  
NIS. 061940111894

JUDUL GAMBAR  
  
PETA KONTUR TRASE

NOMOR GAMBAR  
  
JUMLAH GAMBAR

SKALA  
  
1 : 200  
1 : 1000

**POLITEKNIK  
NEGERI SRIWIJAYA  
PALEMBANG**

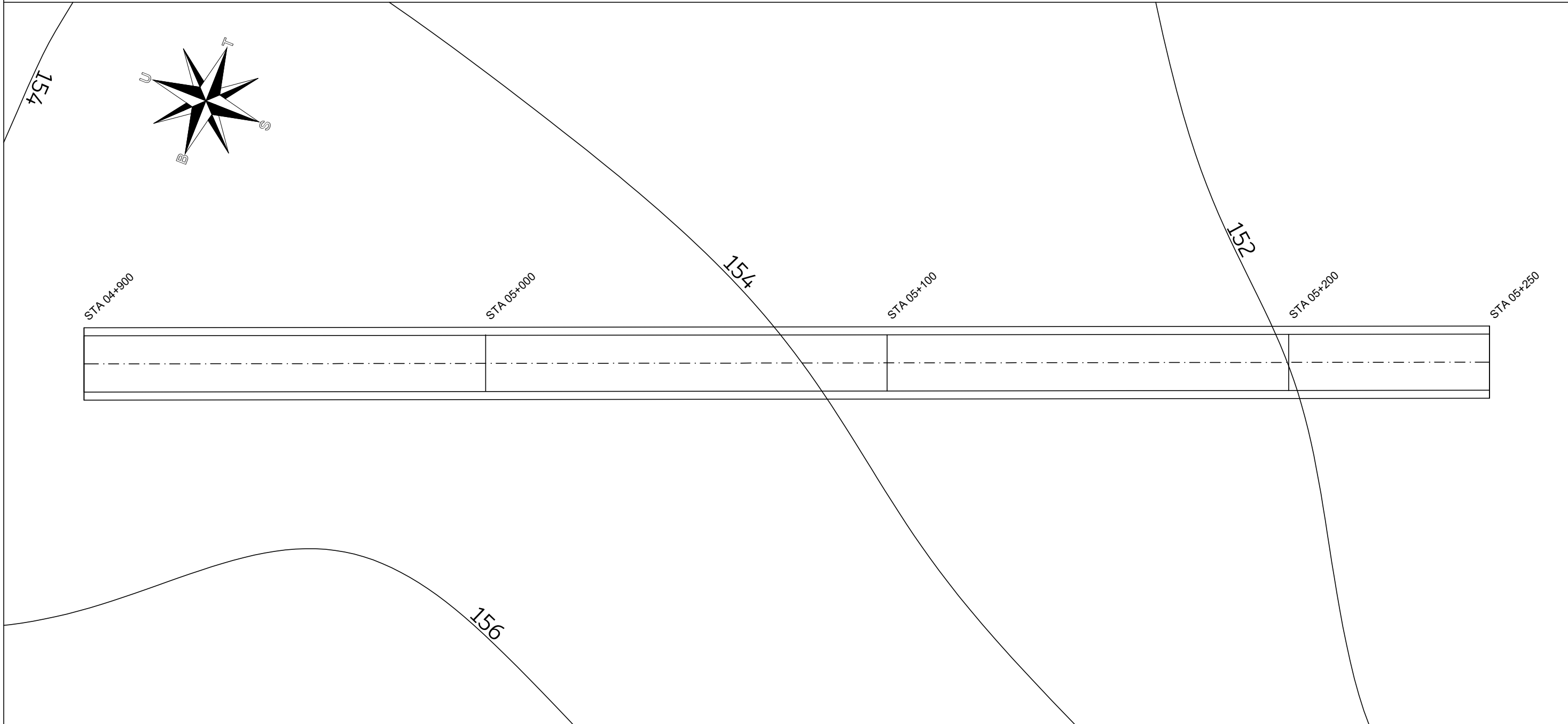

159						159
158						158
157						157
156						156
155						155
154						154
153						153
152						152
151						151
150						150
STA	04+900	05+000	05+100	05+200	05+250	STA
Elevasi Tanah Asli	155,211	155,039	153,742	152,000	151,084	Elevasi Tanah Asli
Elevasi Rencana	152,498	152,736	152,736	151,981	151,197	Elevasi Rencana

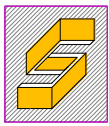

**PERENCANAAN GEOMETRIK DAN TEBAL PERKERASAN KAKU  
JALAN LINGKAR BARAT SP. SPORT CENTER - BUKIT SULAP  
KOTA LUBUKLINGGAU STA 00+000 - 08+150  
PROVINSI SUMATERA SELATAN**

PEMBIMBING I	PEMBIMBING II	DIGAMBAR OLEH :		JUDUL GAMBAR	NOMOR GAMBAR	SKALA
Mahmuda, S.T., M.T. NIP. 196207011989032002	Drs. Bambang H. Fuady, S.T., M.M., M.T. NIP. 195807161986031004	Dwi Andra Octami Darma NISL. 061940111879	Rangga Ismunda NISL. 061940111894	PETA KONTUR TRASE	JUMLAH GAMBAR	1 : 200 1 : 1000

**POLITEKNIK  
NEGERI SRIWIJAYA  
PALEMBANG**

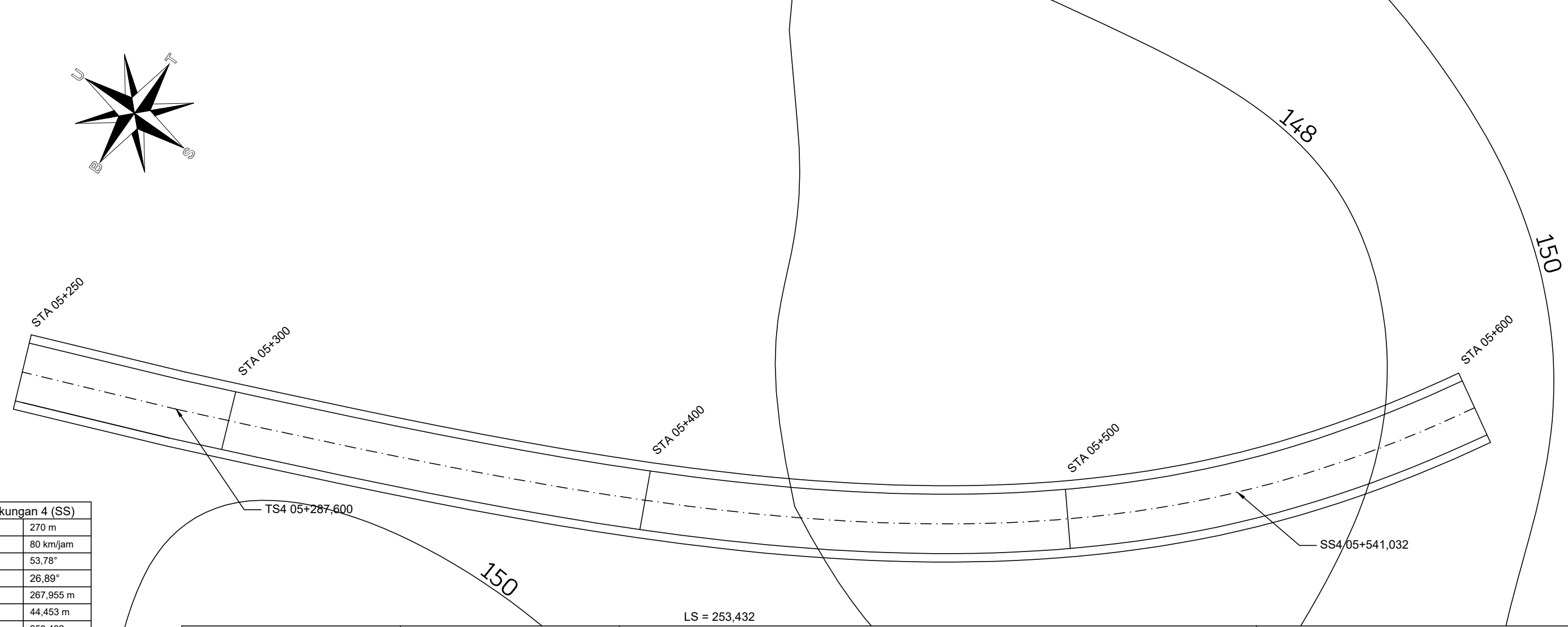
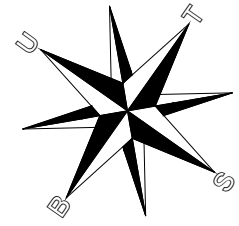

R	270 m
V	80 km/jam
Δ	53,78°
θs	26,89°
Ts	267,955 m
Es	44,453 m
Ls	253,432 m
R min	229,062 m
e	7,82 %
p	10,454 m
k	125,955 m
L total	506,865 m

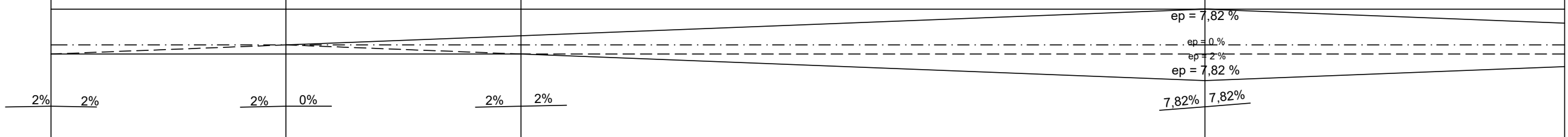

155							155
154							154
153							153
152							152
151							151
150							150
149							149
148							148
147							147
146							146

STA	05+250	05+300	05+400	05+500	05+600	STA
Elevasi Tanah Asli	151,084	150,168	150,289	148,000	149,000	Elevasi Tanah Asli
Elevasi Rencana	151,197	150,413	148,855	148,560	148,560	Elevasi Rencana

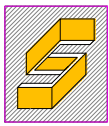

**PERENCANAAN GEOMETRIK DAN TEBAL PERKERASAN KAKU**  
**JALAN LINGKAR BARAT SP. SPORT CENTER - BUKIT SULAP**  
**KOTA LUBUKLINGGAU STA 00+000 - 08+150**  
**PROVINSI SUMATERA SELATAN**

PEMBIMBING I  
 Mahmuda, S.T., M.T.  
 NIP. 196207011989032002

PEMBIMBING II  
 Drs. Bambang H. Fuady, S.T., M.M., M.T.  
 NIP. 195807161986031004

DIGAMBAR OLEH :  
 Dwi Andra Octoni Darma  
 NIM. 061940111879

Rangga Ismunda  
 NIM. 061940111894

JUDUL GAMBAR  
 PETA KONTUR TRASE

NOMOR GAMBAR  
 JUMLAH GAMBAR

SKALA  
 1 : 200  
 1 : 1000

**POLITEKNIK**  
**NEGERI SRIWIJAYA**  
**PALEMBANG**

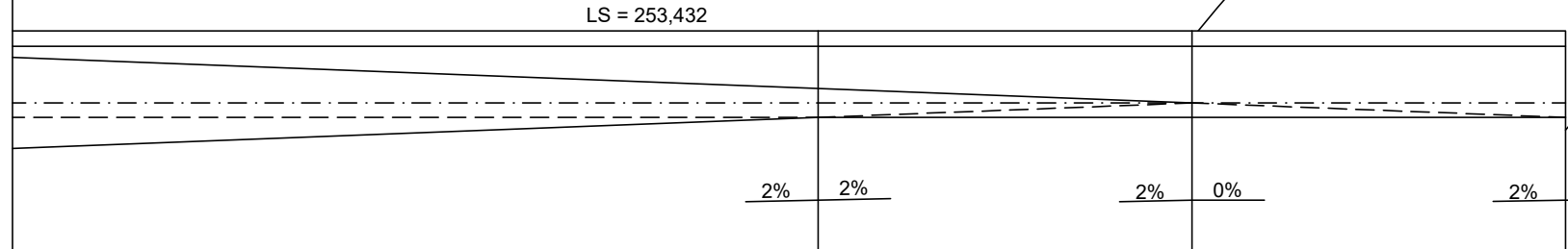
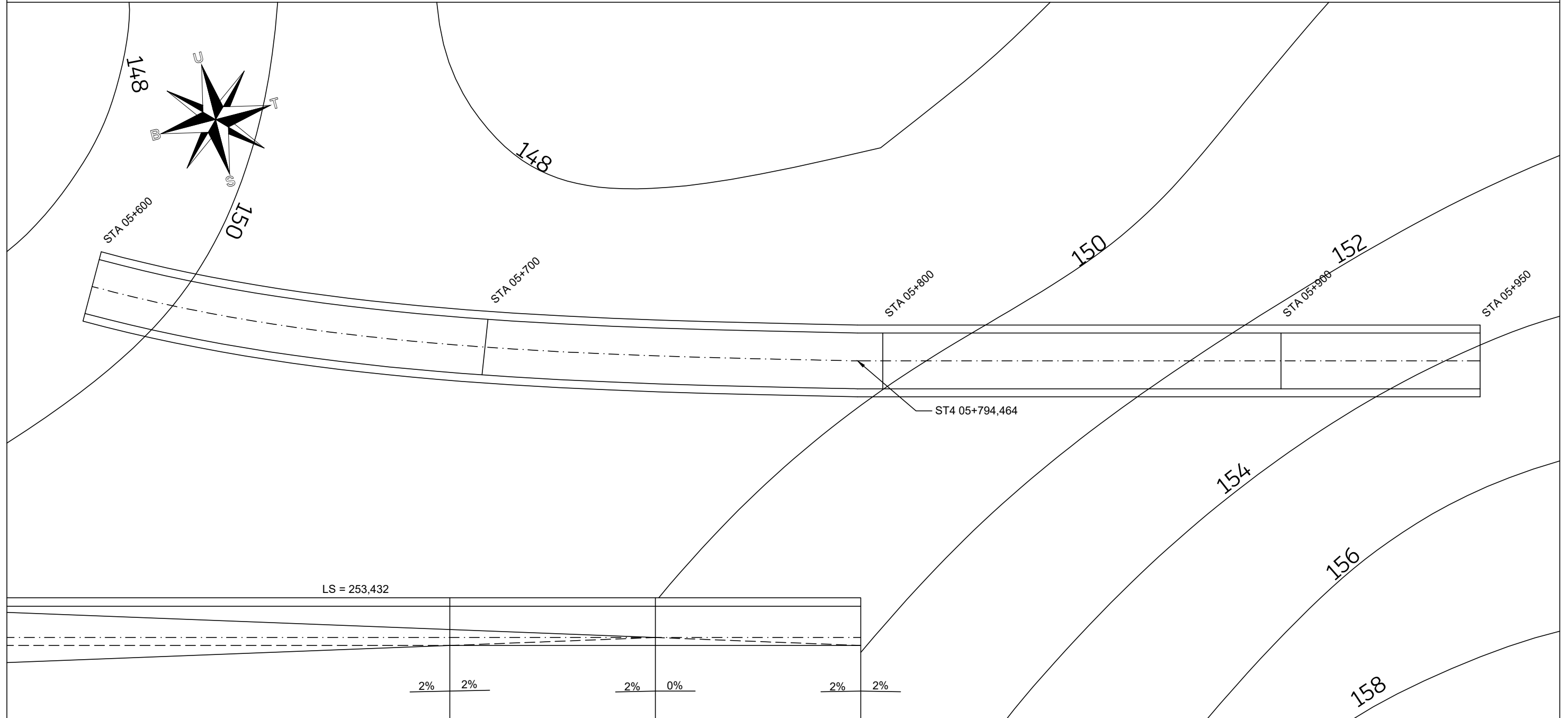

155						155
154						154
153						153
152						152
151						151
150						150
149						149
148						148
147						147
146						146
STA	05+600	05+700	05+800	05+900	05+950	STA
Elevasi Tanah Asli	149,000	148,534	149,768	152,741	153,813	Elevasi Tanah Asli
Elevasi Rencana	148,560	149,560	149,673	151,796	152,698	Elevasi Rencana

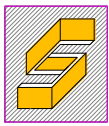

**PERENCANAAN GEOMETRIK DAN TEBAL PERKERASAN KAKU  
JALAN LINGKAR BARAT SP. *SPORT CENTER* - BUKIT SULAP  
KOTA LUBUKLINGGAU STA 00+000 - 08+150  
PROVINSI SUMATERA SELATAN**

PEMBIMBING I  
  
Mahmuda, S.T., M.T.  
NIP. 196207011989032002

PEMBIMBING II  
  
Drs. Bambang H. Fuady, S.T., M.M., M.T.  
NIP. 195807161986031004

DIGAMBAR OLEH :  
  
Dwi Andra Octami Darma  
NIM. 061940111879

JUDUL GAMBAR  
  
PETA KONTUR TRASE

NOMOR GAMBAR  
  
JUMLAH GAMBAR

SKALA  
  
1 : 200  
1 : 1000

**POLITEKNIK  
NEGERI SRIWIJAYA  
PALEMBANG**

Tikungan 5 (SS)	
R	250 m
V	80 km/jam
$\Delta$	55,887°
$\theta_s$	27,944°
Ts	259,081 m
Es	44,875 m
Ls	243,853 m
R min	229,062 m
e	7,9 %
p	10,495 m
k	120,903 m
L total	487,706 m

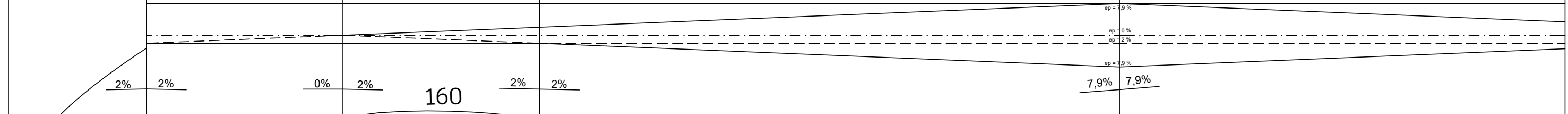
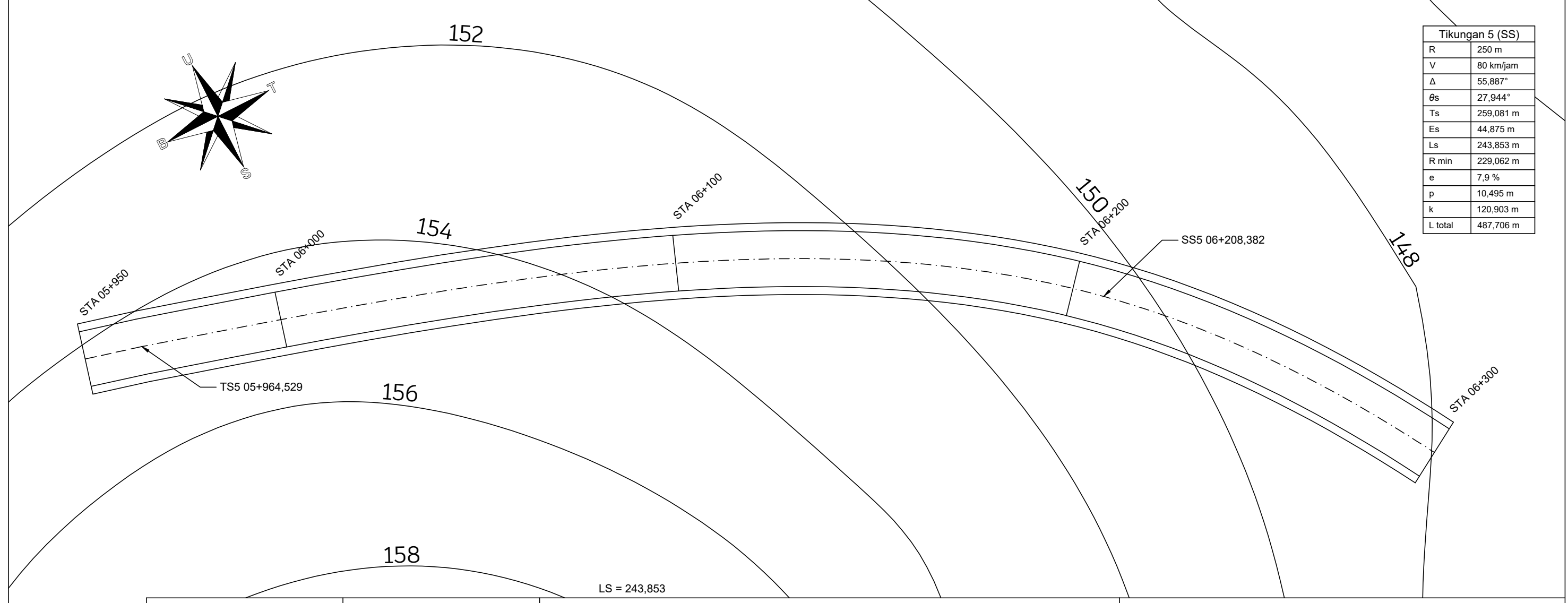

155						155
154						154
153						153
152						152
151						151
150						150
149						149
148						148
147						147
146						146
STA	05+950	06+000	06+100	06+200	06+300	STA
Elevasi Tanah Asli	153,813	154,884	153,400	150,701	147,974	Elevasi Tanah Asli
Elevasi Rencana	152,698	153,599	152,243	149,653	147,064	Elevasi Rencana



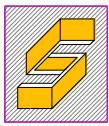

**PERENCANAAN GEOMETRIK DAN TEBAL PERKERASAN KAKU**  
**JALAN LINGKAR BARAT SP. SPORT CENTER - BUKIT SULAP**  
**KOTA LUBUKLINGGAU STA 00+000 - 08+150**  
**PROVINSI SUMATERA SELATAN**

PEMBIMBING I  
 Mahmuda, S.T., M.T.  
 NIP. 196207011989032002

PEMBIMBING II  
 Drs. Bambang H. Fuady, S.T., M.M., M.T.  
 NIP. 195807161986031004

DIGAMBAR OLEH :  
 Dwi Andra Octami Darma  
 NIM. 061940111879

Rangga Isnanda  
 NIM. 061940111894

JUDUL GAMBAR  
 PETA KONTUR TRASE

NOMOR GAMBAR  
 JUMLAH GAMBAR

SKALA  
 1 : 200  
 1 : 1000

**POLITEKNIK**  
**NEGERI SRIWIJAYA**  
**PALEMBANG**

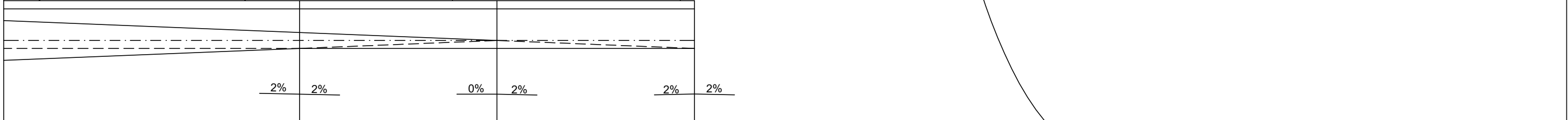
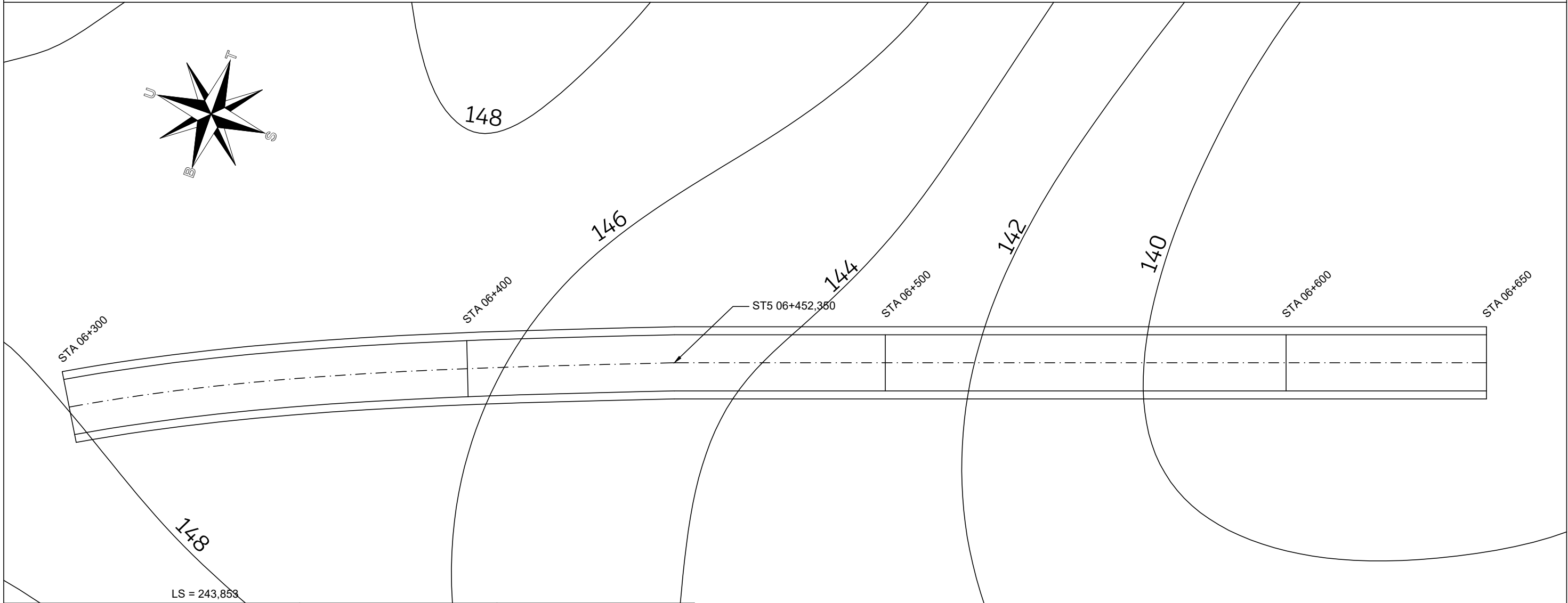

148						148
147						147
146						146
145						145
144						144
143						143
142						142
141						141
140						140
139						139
STA	06+300	06+400	06+500	06+600	06+650	STA
Elevasi Tanah Asli	147,974	146,487	143,200	140,000	139,715	Elevasi Tanah Asli
Elevasi Rencana	147,064	144,641	143,041	141,450	140,655	Elevasi Rencana

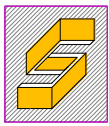

**PERENCANAAN GEOMETRIK DAN TEBAL PERKERASAN KAKU  
JALAN LINGKAR BARAT SP. *SPORT CENTER* - BUKIT SULAP  
KOTA LUBUKLINGGAU STA 00+000 - 08+150  
PROVINSI SUMATERA SELATAN**

PEMBIMBING I  Mahmuda, S.T., M.T. NIP. 196207011989032002	PEMBIMBING II  Drs. Bambang H. Fuady, S.T., M.M., M.T. NIP. 195807161986031004	DIGAMBAR OLEH :  Dwi Andra Octami Darma NIS. 061940111879		Rangga Ismanda NIS. 061940111894	JUDUL GAMBAR  PETA KONTUR TRASE	NOMOR GAMBAR  JUMLAH GAMBAR	SKALA  1 : 200 1 : 1000	POLITEKNIK NEGERI SRIWIJAYA PALEMBANG
--	---	--	--	-------------------------------------	---------------------------------------	-----------------------------------	----------------------------------	---

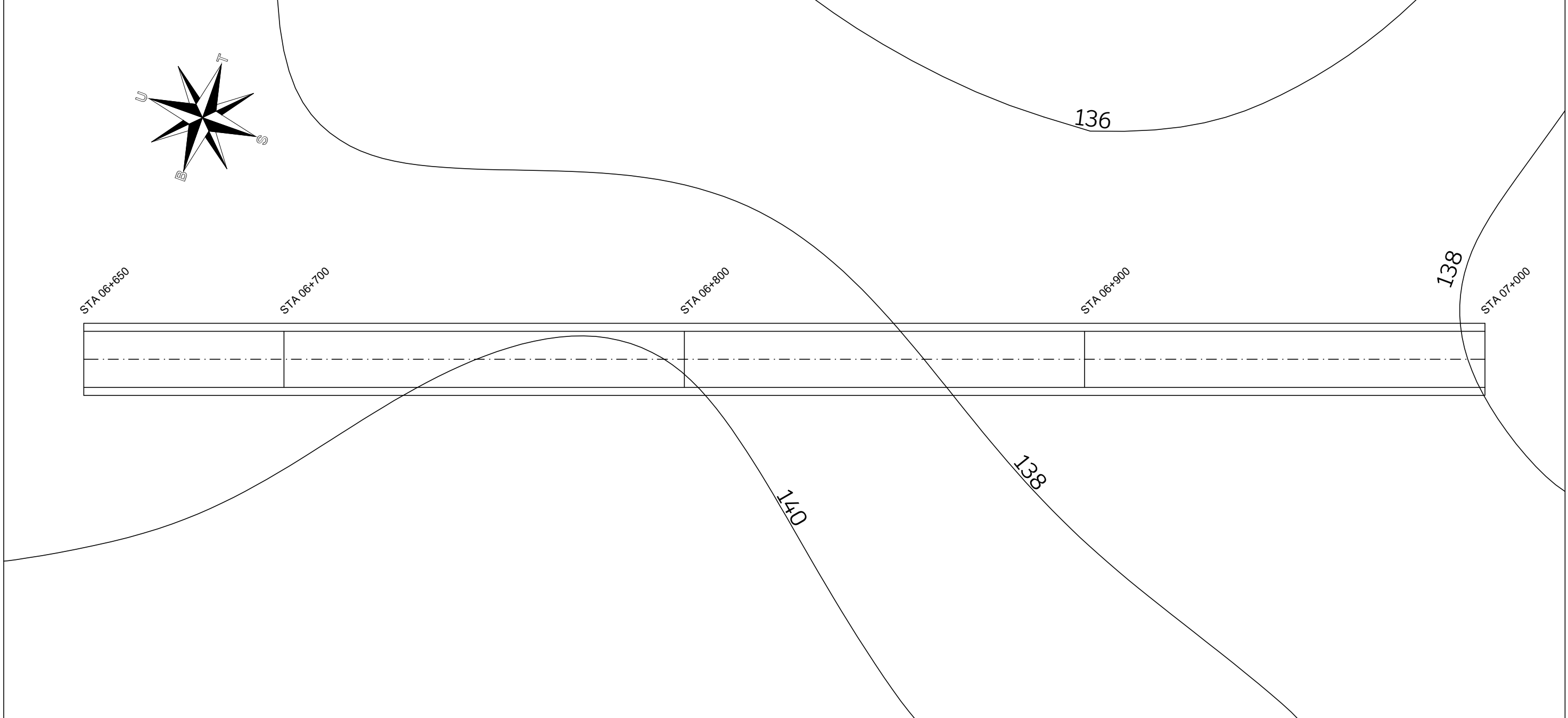

145						145
144						144
143						143
142						142
141						141
140						140
139						139
138						138
137						137
136						136
STA	06+650	06+700	06+800	06+900	07+000	STA
Elevasi Tanah Asli	139,715	139,430	139,933	137,114	138,000	Elevasi Tanah Asli
Elevasi Rencana	140,655	139,860	138,555	138,544	138,544	Elevasi Rencana

— MUKA TANAH ASLI

- - - DESAIN RENCANA

BOX CULVERT 016  
SENGKANG Ø10  
STA 06+820

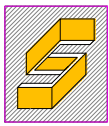

**PERENCANAAN GEOMETRIK DAN TEBAL PERKERASAN KAKU**  
**JALAN LINGKAR BARAT SP. SPORT CENTER - BUKIT SULAP**  
**KOTA LUBUKLINGGAU STA 00+000 - 08+150**  
**PROVINSI SUMATERA SELATAN**

PEMBIMBING I  
 Mahmuda, S.T., M.T.  
 NIP. 196207011989032002

PEMBIMBING II  
 Drs. Bambang H. Fuady, S.T., M.M., M.T.  
 NIP. 195807161986031004

DIGAMBAR OLEH :  
 Dwi Andra Octami Darma  
 NIM. 061940111879

Rangga Isnanda  
 NIM. 061940111894

JUDUL GAMBAR  
 PETA KONTUR TRASE

NOMOR GAMBAR  
 JUMLAH GAMBAR

SKALA  
 1 : 200  
 1 : 1000

**POLITEKNIK**  
**NEGERI SRIWIJAYA**  
**PALEMBANG**

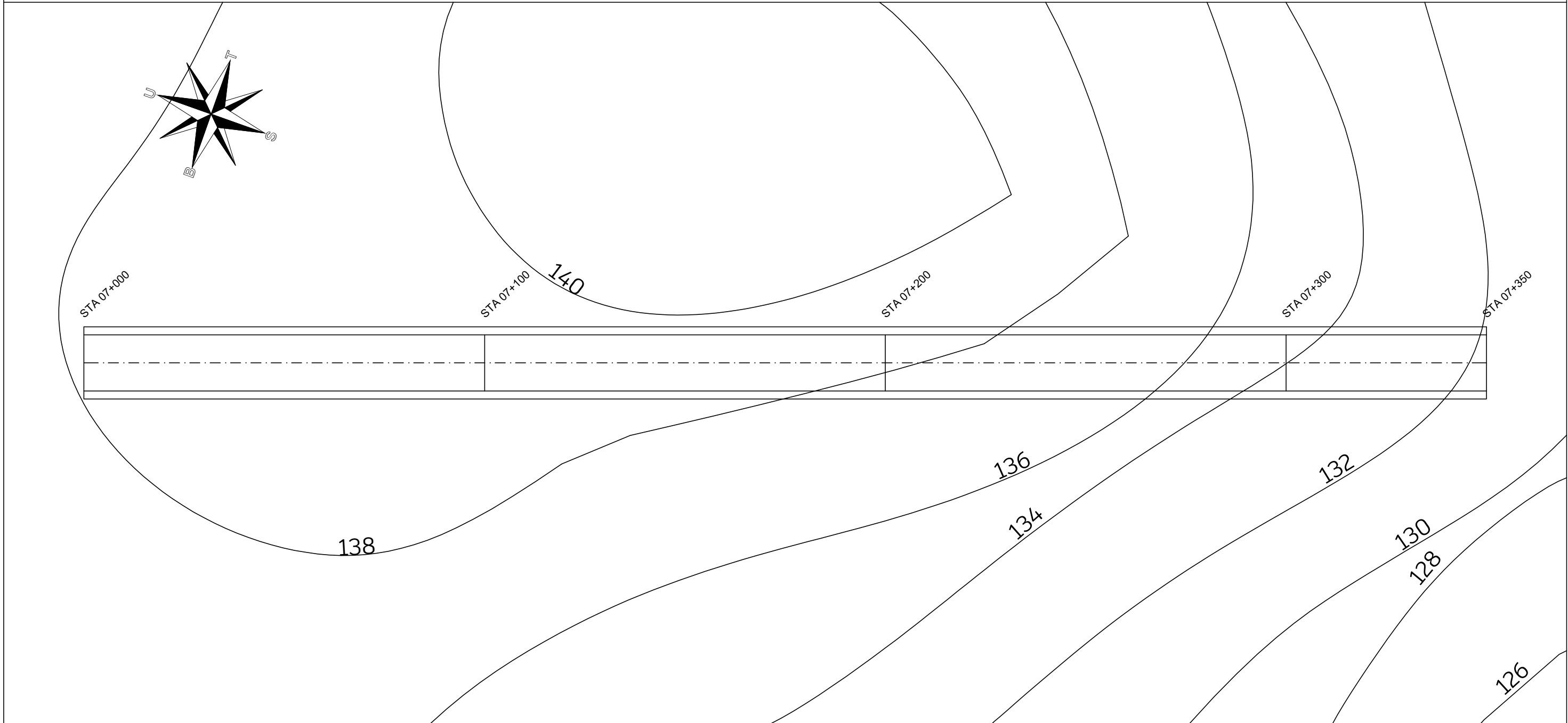

139						139
138						138
137						137
136						136
135						135
134						134
133						133
132						132
131						131
130						130
STA	07+000	07+100	07+200	07+300	07+350	STA
Elevasi Tanah Asli	138,000	139,027	138,000	133,150	130,575	Elevasi Tanah Asli
Elevasi Rencana	138,544	138,544	137,456	133,557	131,536	Elevasi Rencana

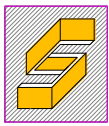

**PERENCANAAN GEOMETRIK DAN TEBAL PERKERASAN KAKU  
JALAN LINGKAR BARAT SP. *SPORT CENTER* - BUKIT SULAP  
KOTA LUBUKLINGGAU STA 00+000 - 08+150  
PROVINSI SUMATERA SELATAN**

PEMBIMBING I  Mahmuda, S.T., M.T. NIP. 196207011989032002	PEMBIMBING II  Drs. Bambang H. Fuady, S.T., M.M., M.T. NIP. 195807161986031004	DIGAMBAR OLEH :  Dwi Andra Octami Darma NISL. 061940111879		Rangga Ismanda NEM. 061940111894	JUDUL GAMBAR  PETA KONTUR TRASE	NOMOR GAMBAR  JUMLAH GAMBAR	SKALA  1 : 200 1 : 1000	<b>POLITEKNIK NEGERI SRIWIJAYA PALEMBANG</b>
--	---	---	--	-------------------------------------	---------------------------------------	-----------------------------------	----------------------------------	--

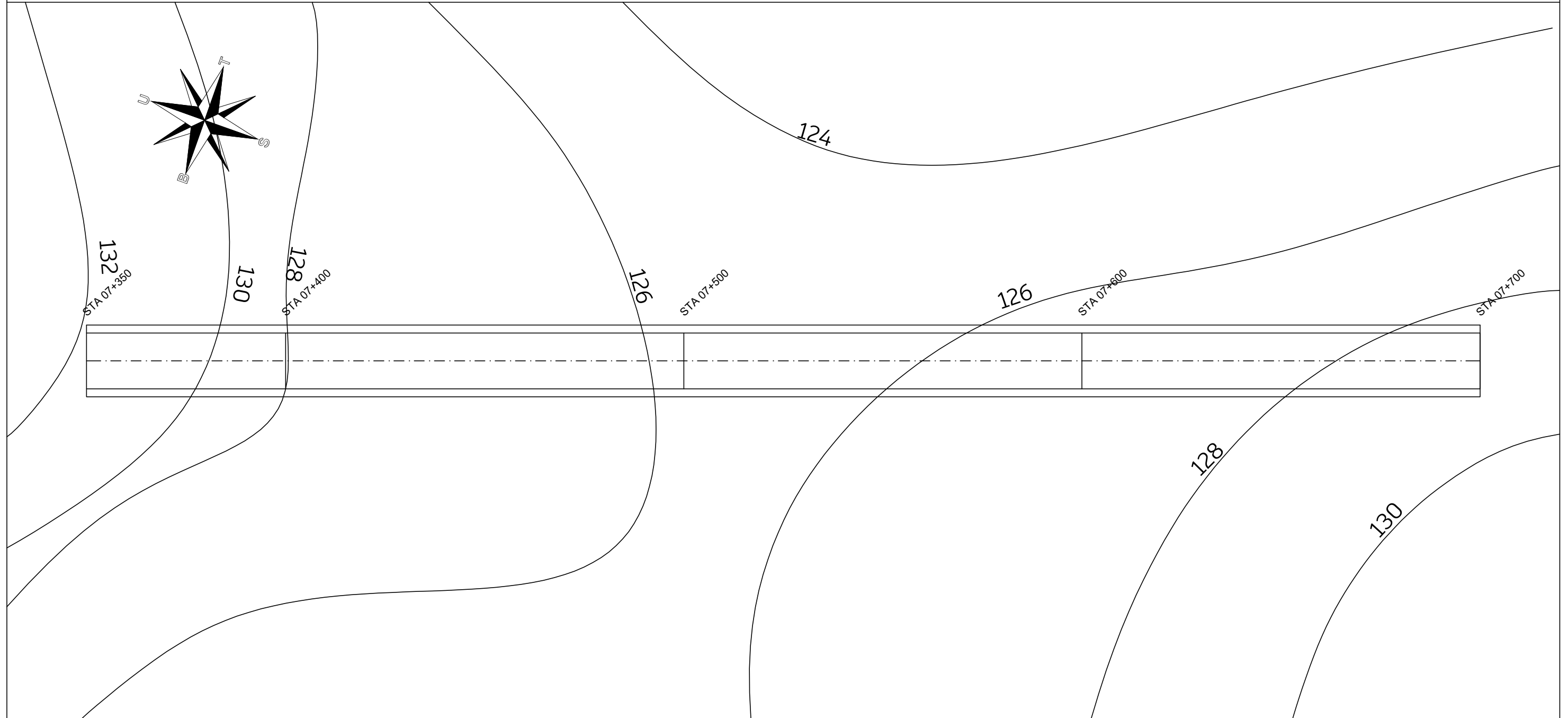

133						133
132						132
131						131
130						130
129						129
128						128
127						127
126						126
125						125
124						124
STA	07+350	07+400	07+500	07+600	07+700	STA
Elevasi Tanah Asli	130,575	128,000	126,000	126,312	128,765	Elevasi Tanah Asli
Elevasi Rencana	131,536	129,515	126,933	126,807	126,807	Elevasi Rencana

BOX CULVERT Ø16  
SENGKANG Ø10  
STA 07+500



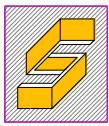

**PERENCANAAN GEOMETRIK DAN TEBAL PERKERASAN KAKU**  
**JALAN LINGKAR BARAT SP. SPORT CENTER - BUKIT SULAP**  
**KOTA LUBUKLINGGAU STA 00+000 - 08+150**  
**PROVINSI SUMATERA SELATAN**

PEMBIMBING I  
 Mahmuda, S.T., M.T.  
 NIP. 196207011989032002

PEMBIMBING II  
 Drs. Bambang H. Fuady, S.T., M.M., M.T.  
 NIP. 195807161986031004

DIGAMBAR OLEH :  
 Dwi Andra Octami Darma  
 NIM. 061940111879

Rangga Ismanda  
 NIM. 061940111894

JUDUL GAMBAR  
 PETA KONTUR TRASE

NOMOR GAMBAR  
 JUMLAH GAMBAR

SKALA  
 1 : 200  
 1 : 1000

**POLITEKNIK**  
**NEGERI SRIWIJAYA**  
**PALEMBANG**

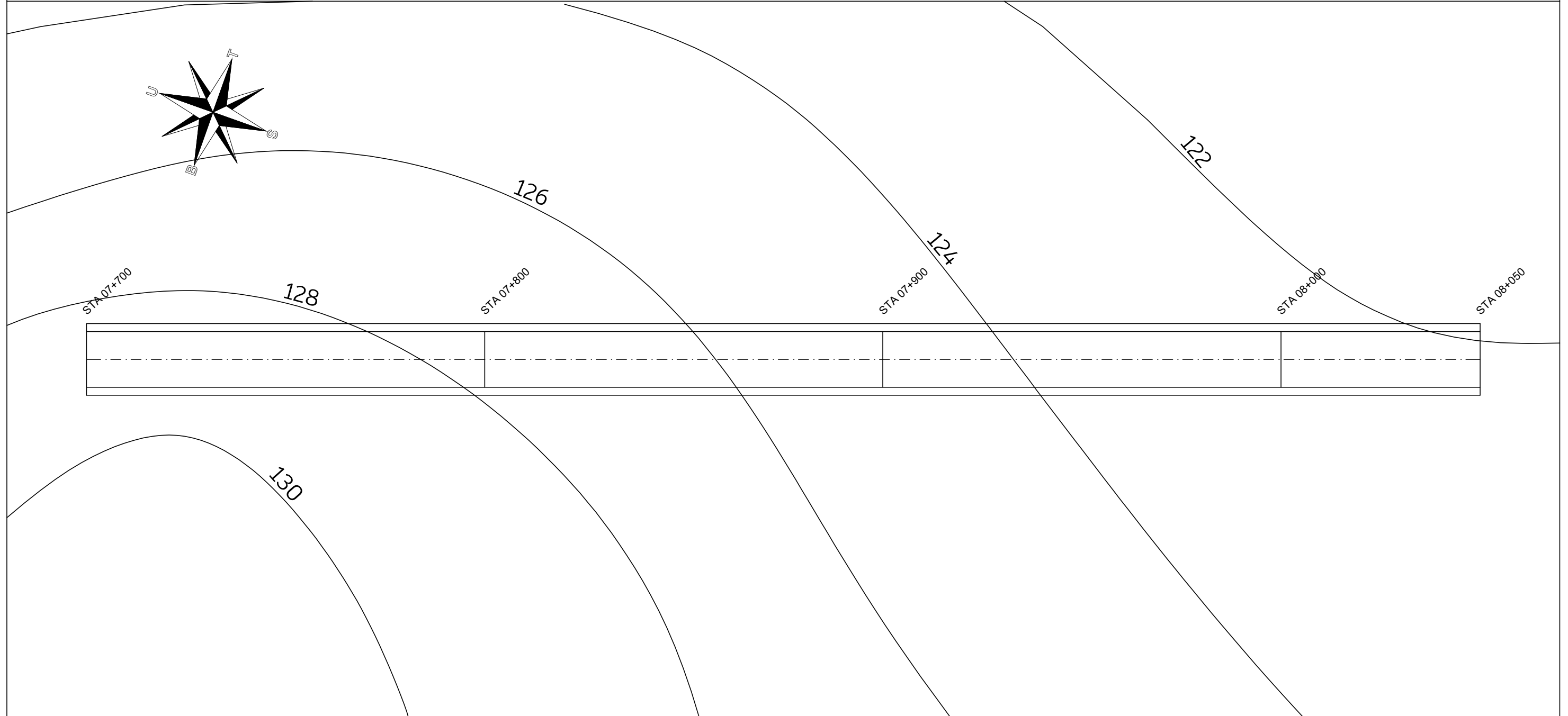

130						130
129						129
128						128
127						127
126						126
125						125
124						124
123						123
122						122
121						121
STA	07+700	07+800	07+900	08+000	08+050	STA
Elevasi Tanah Asli	128,765	127,610	124,772	122,493	122,315	Elevasi Tanah Asli
Elevasi Rencana	126,807	126,807	126,041	124,725	124,067	Elevasi Rencana

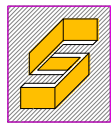

**PERENCANAAN GEOMETRIK DAN TEBAL PERKERASAN KAKU  
 JALAN LINGKAR BARAT SP. *SPORT CENTER* - BUKIT SULAP  
 KOTA LUBUKLINGGAU STA 00+000 - 08+150  
 PROVINSI SUMATERA SELATAN**

PEMBIMBING I	PEMBIMBING II	DIGAMBAR OLEH :		JUDUL GAMBAR	NOMOR GAMBAR	SKALA
Mahmuda, S.T., M.T. NIP. 196207011989032002	Drs. Bambang H. Fuady, S.T., M.M., M.T. NIP. 195807161986031004	Dwi Andra Octami Darma NIS. 061940111879	Rangga Ismunda NIS. 061940111894	PETA KONTUR TRASE	JUMLAH GAMBAR	1 : 200 1 : 1000

**POLITEKNIK  
 NEGERI SRIWIJAYA  
 PALEMBANG**

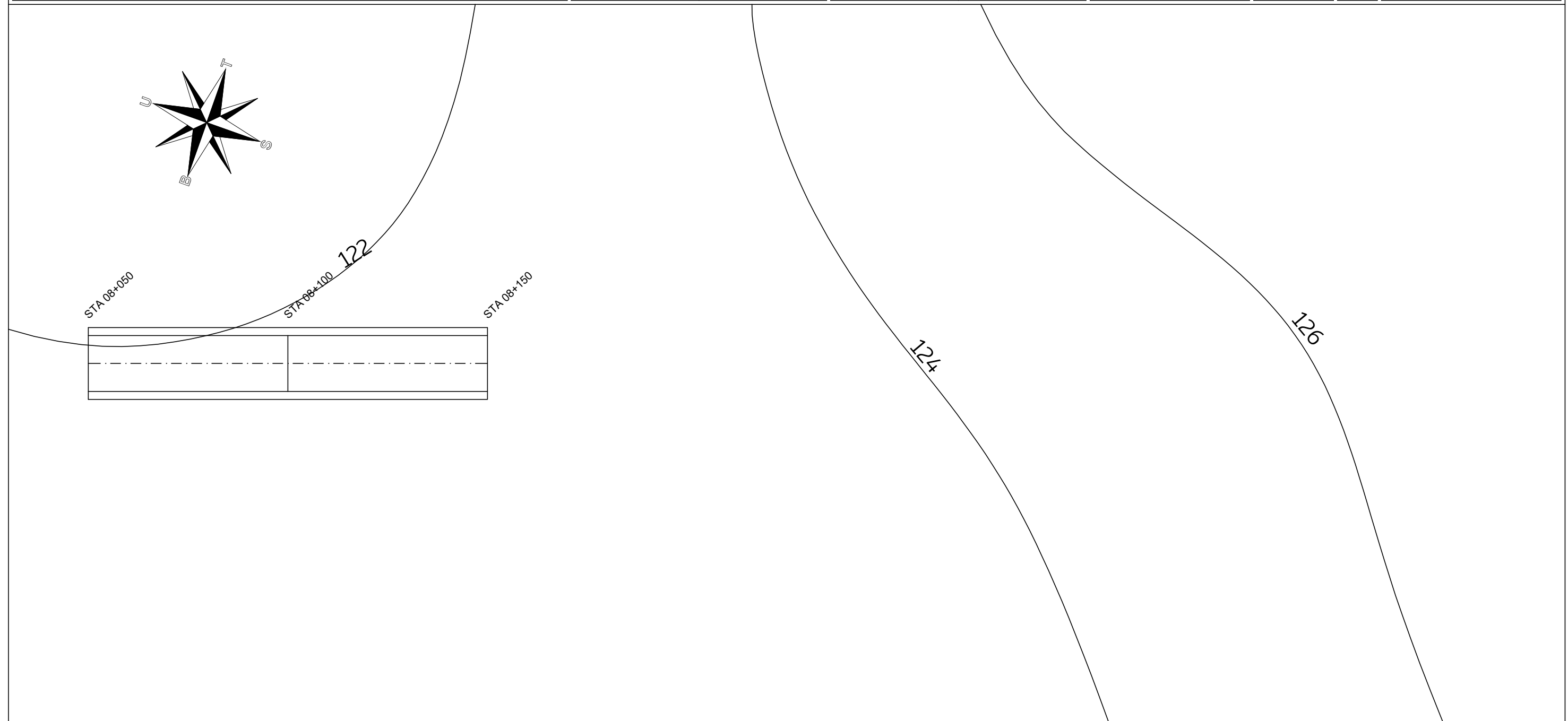

130				130
129				129
128				128
127				127
126				126
125				125
124		DESAIN RENCANA		124
123	MUKA TANAH ASLI			123
122				122
121				121
STA	08+050	08+100	08+150	STA
Elevasi Tanah Asli	122,315	122,136	122,751	Elevasi Tanah Asli
Elevasi Rencana	124,067	123,409	122,751	Elevasi Rencana

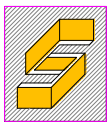

**PERENCANAAN GEOMETRIK DAN TEBAL PERKERASAN KAKU**  
**JALAN LINGKAR BARAT SP. SPORT CENTER - BUKIT SULAP**  
**KOTA LUBUKLINGGAU STA 00+000 - 08+150**  
**PROVINSI SUMATERA SELATAN**

PEMBIMBING I  
 Mahmuda, S.T., M.T.  
 NIP. 196207011989032062

PEMBIMBING II  
 Drs. Bambang H. Fuady, S.T., M.M., M.T.  
 NIP. 195807161986031004

DIGAMBAR OLEH :  
 Dwi Andra Octoni Darma  
 NIM. 061940111879  
 Rangga Isnanda  
 NIM. 061940111891

JUDUL GAMBAR  
 POTONGAN MELINTANG

NOMOR GAMBAR  
 JUMLAH GAMBAR

SKALA  
 1 : 200

**POLITEKNIK**  
**NEGERI SRIWIJAYA**  
**PALEMBANG**

STA 00+000

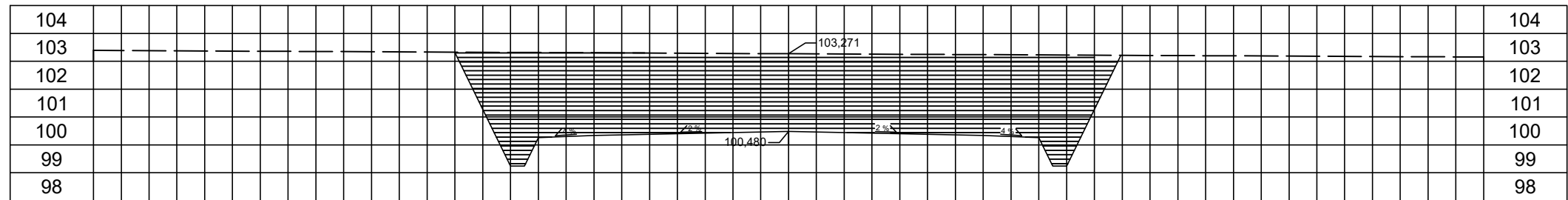

STA 00+100

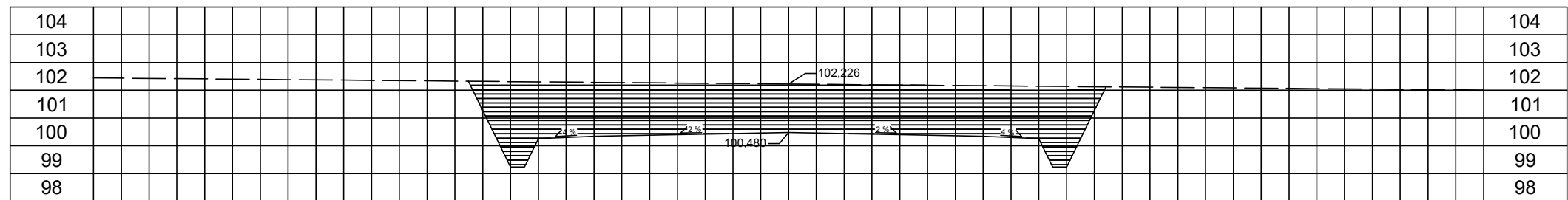

STA 00+200

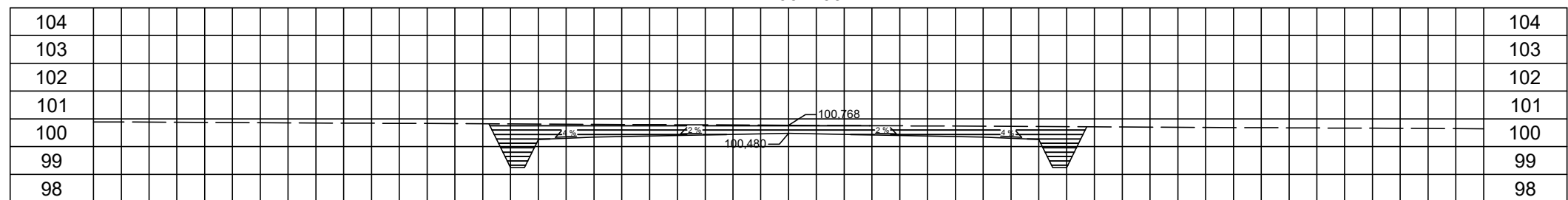

STA 00+300

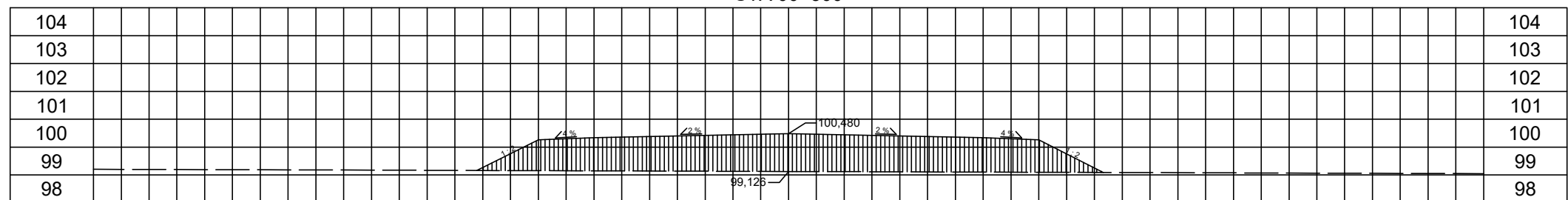

STA 00+400

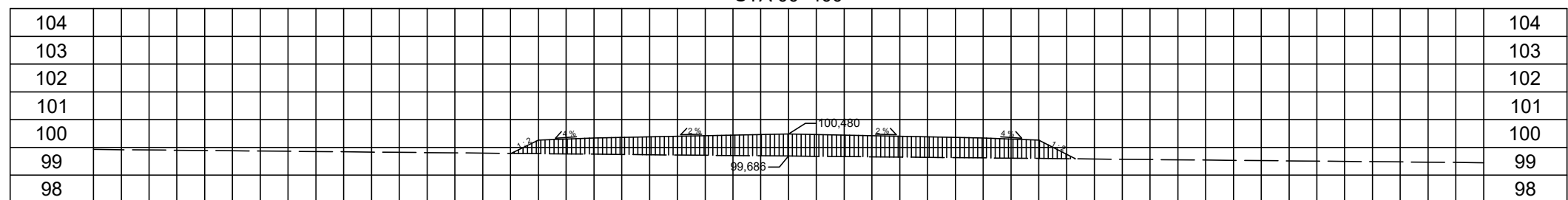

-25      -20      -10      0      10      20      25

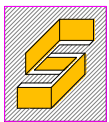

**PERENCANAAN GEOMETRIK DAN TEBAL PERKERASAN KAKU  
JALAN LINGKAR BARAT SP. SPORT CENTER - BUKIT SULAP  
KOTA LUBUKLINGGAU STA 00+000 - 08+150  
PROVINSI SUMATERA SELATAN**

PEMBIMBING I  
  
Mahmuda, S.T., M.T.  
NIP. 196207011989032062

PEMBIMBING II  
  
Drs. Bambang H. Fuady, S.T., M.M., M.T.  
NIP. 195807161986031004

DIGAMBAR OLEH :  
  
Dwi Andra Octoni Darma  
NIM. 061940111879

JUDUL GAMBAR  
  
POTONGAN MELINTANG

NOMOR GAMBAR  
  
JUMLAH GAMBAR

SKALA  
  
1 : 200

**POLITEKNIK  
NEGERI SRIWIJAYA  
PALEMBANG**

STA 00+500

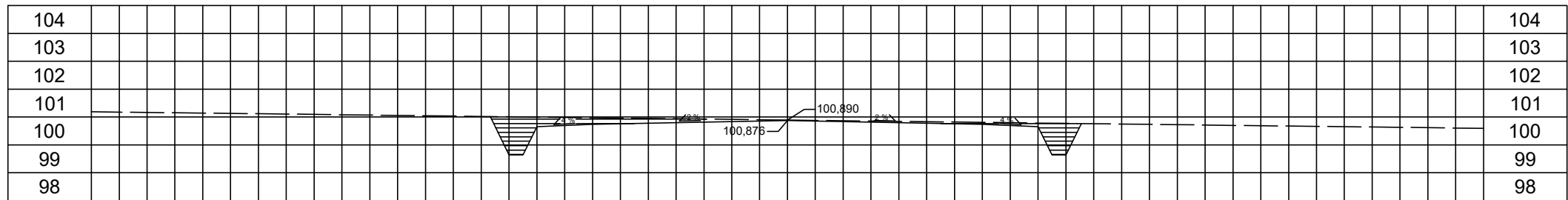

STA 00+600

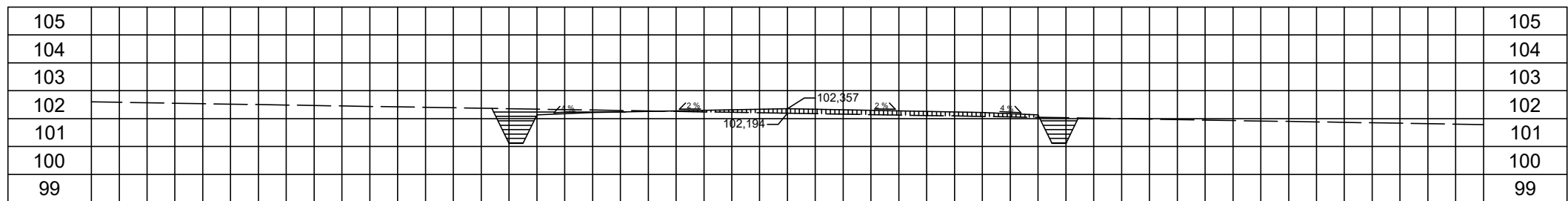

STA 00+700

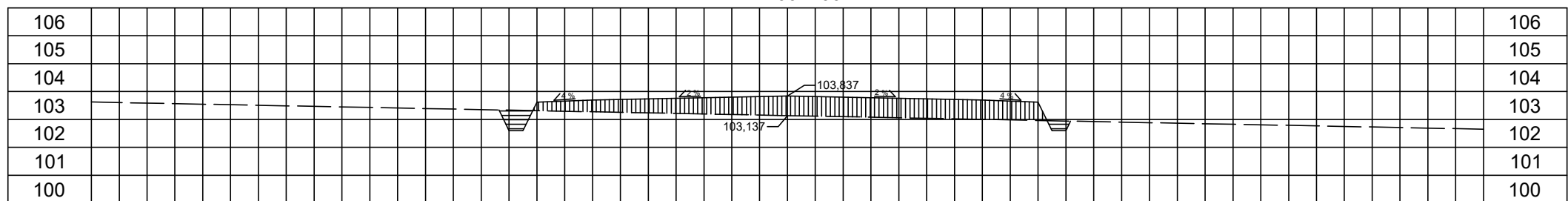

STA 00+800

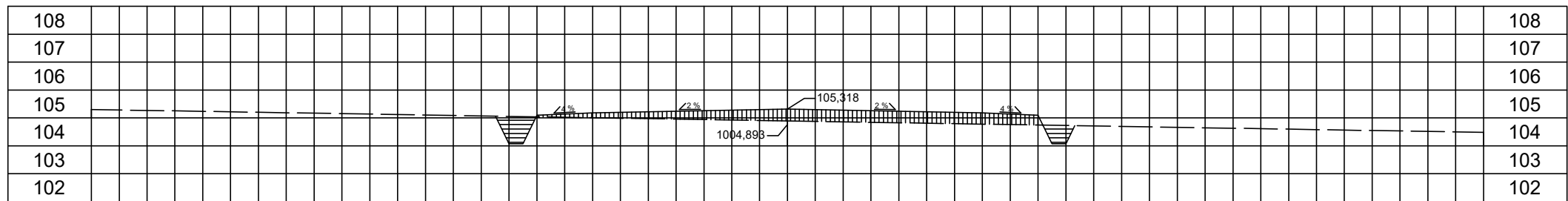

STA 00+900

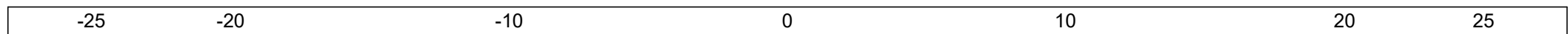
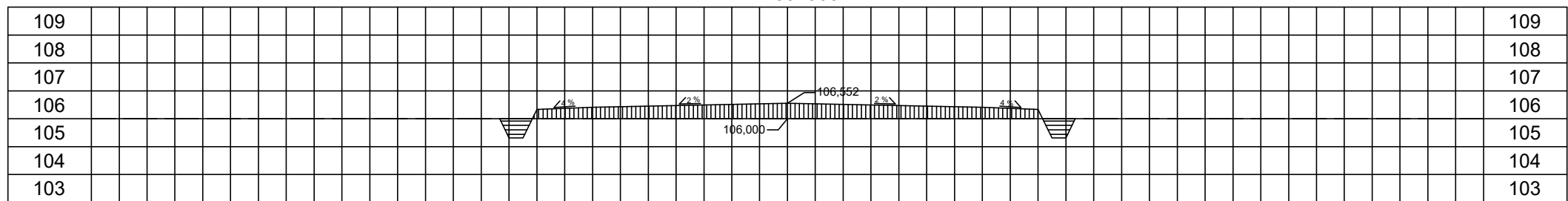





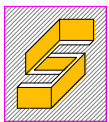

**PERENCANAAN GEOMETRIK DAN TEBAL PERKERASAN KAKU**  
**JALAN LINGKAR BARAT SP. SPORT CENTER - BUKIT SULAP**  
**KOTA LUBUKLINGGAU STA 00+000 - 08+150**  
**PROVINSI SUMATERA SELATAN**

PEMBIMBING I  
 Mahmuda, S.T., M.T.  
 NIP. 196207011989032062

PEMBIMBING II  
 Drs. Bambang H. Fuady, S.T., M.M., M.T.  
 NIP. 195807161986031004

DIGAMBAR OLEH :  
 Dwi Andra Octoni Darma  
 NIM. 061940111879  
 Rangga Isnanda  
 NIM. 061940111891

JUDUL GAMBAR  
 POTONGAN MELINTANG

NOMOR GAMBAR  
 JUMLAH GAMBAR

SKALA  
 1 : 200

**POLITEKNIK**  
**NEGERI SRIWIJAYA**  
**PALEMBANG**

STA 01+400

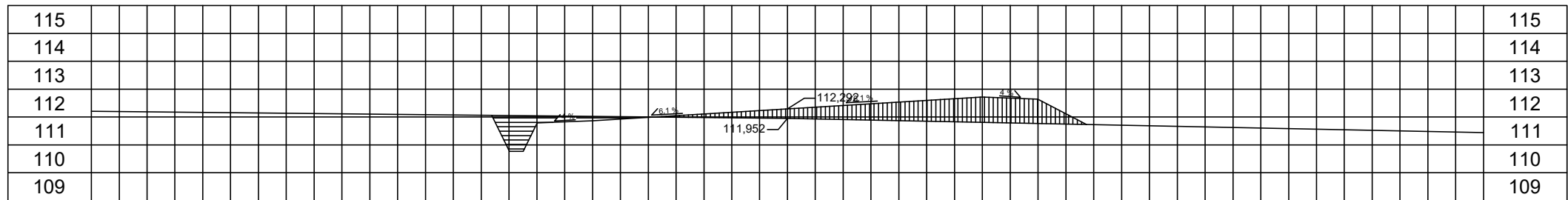

STA 01+500

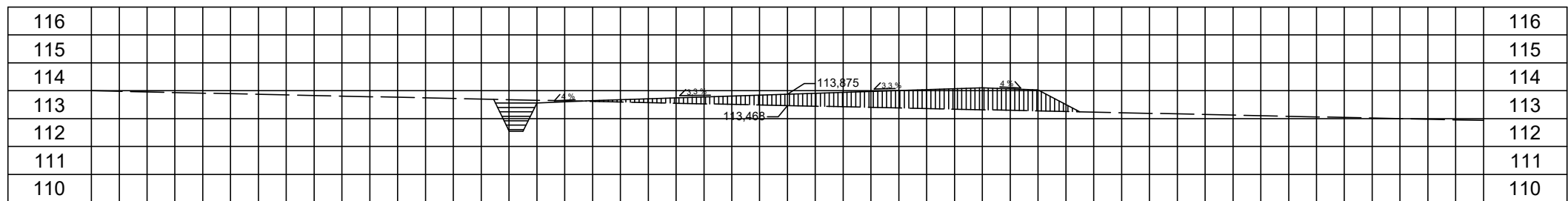

STA 01+600

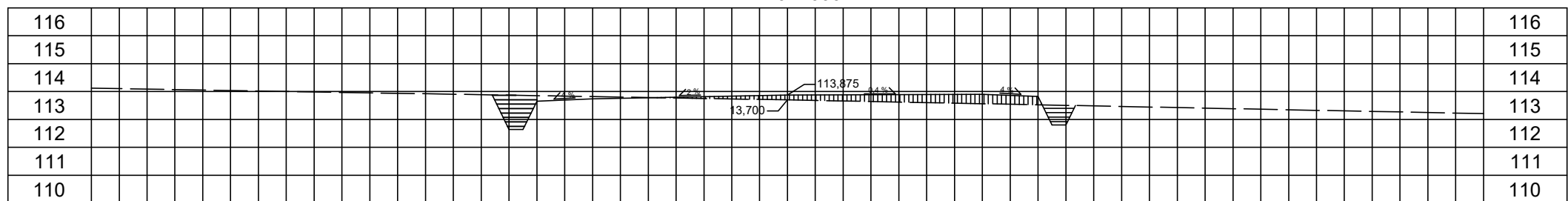

STA 01+700

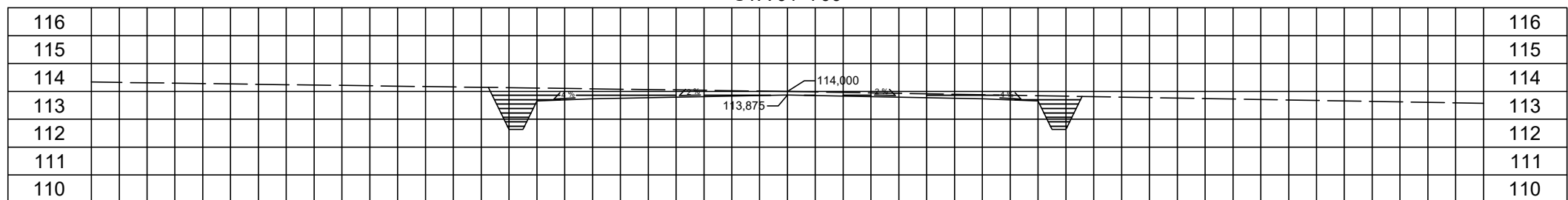

STA 01+800

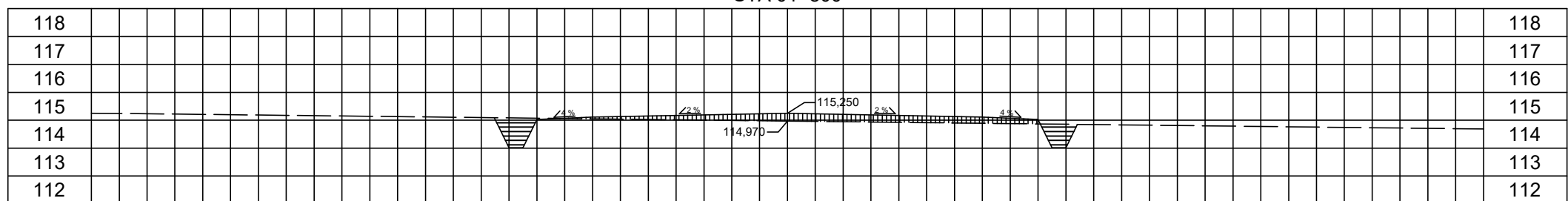

-25      -20      -10      0      10      20      25

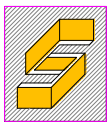

STA 01+900

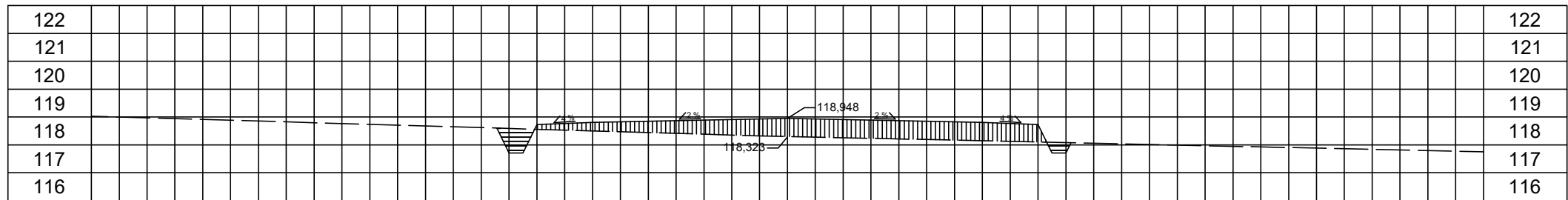

STA 02+000

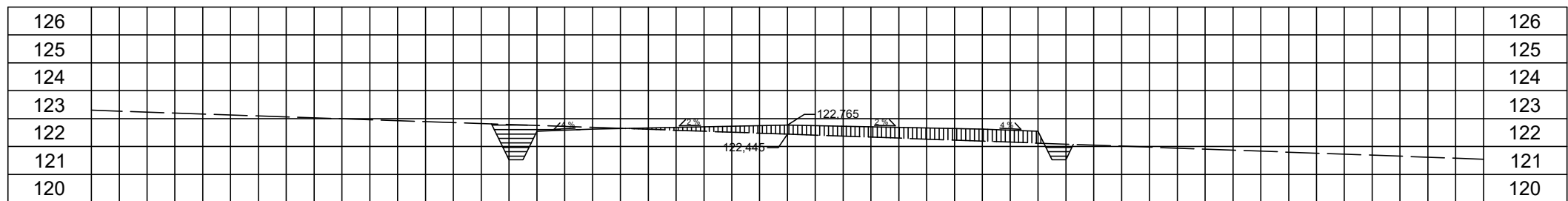

STA 02+100

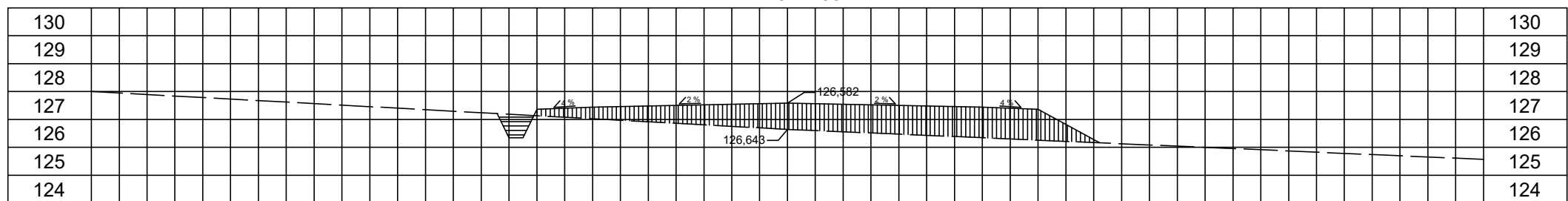

STA 02+200

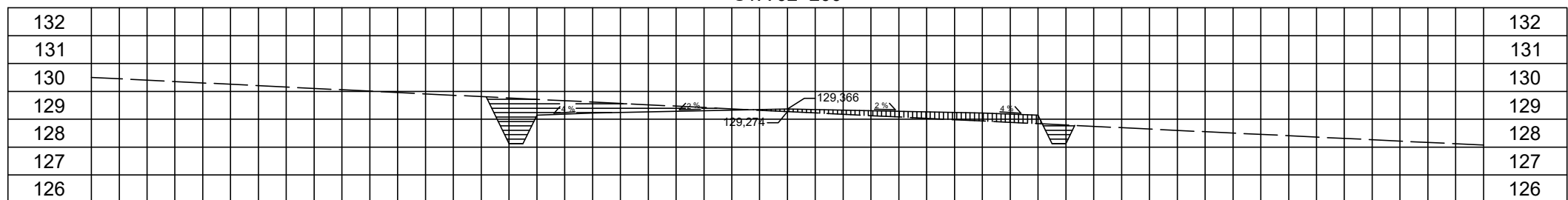

STA 02+300

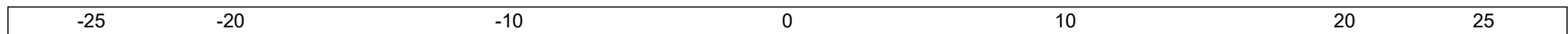
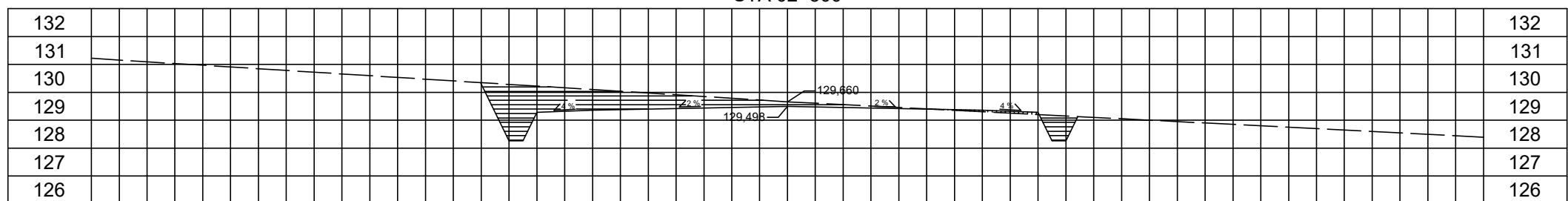

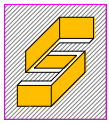

**PERENCANAAN GEOMETRIK DAN TEBAL PERKERASAN KAKU  
JALAN LINGKAR BARAT SP. SPORT CENTER - BUKIT SULAP  
KOTA LUBUKLINGGAU STA 00+000 - 08+150  
PROVINSI SUMATERA SELATAN**

**PEMBIMBING I**  
  
Mahmuda, S.T., M.T.  
NIP. 196207011989032062

**PEMBIMBING II**  
  
Drs. Bambang H. Fandy, S.T., M.M., M.T.  
NIP. 195807161986031004

**DIGAMBAR OLEH :**  
  
Dwi Andra Octoni Darma  
NIM. 061940111879

**JUDUL GAMBAR**  
  
POTONGAN MELINTANG

**NOMOR GAMBAR**  
  
Jumlah Gambar

**SKALA**  
  
1 : 200

**POLITEKNIK  
NEGERI SRIWIJAYA  
PALEMBANG**

**STA 02+400**

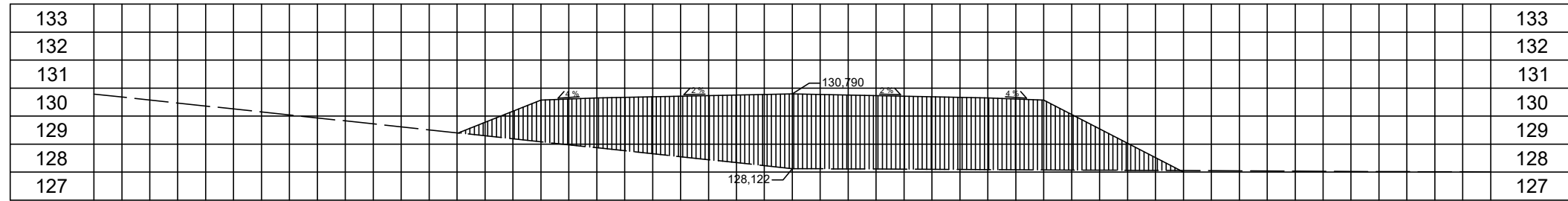

**STA 02+500**

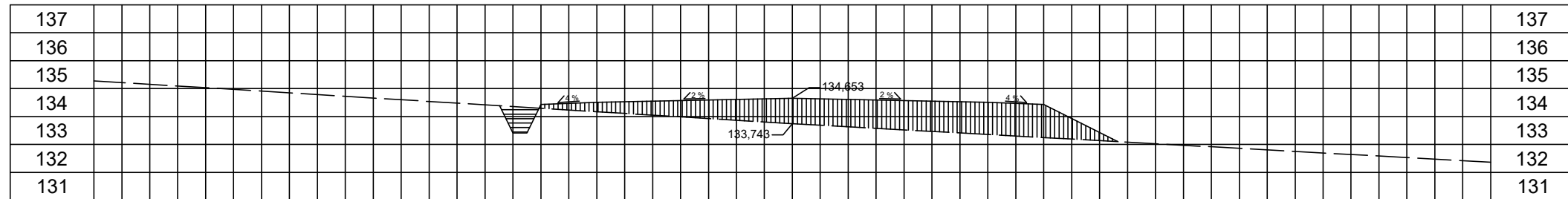

**STA 02+600**

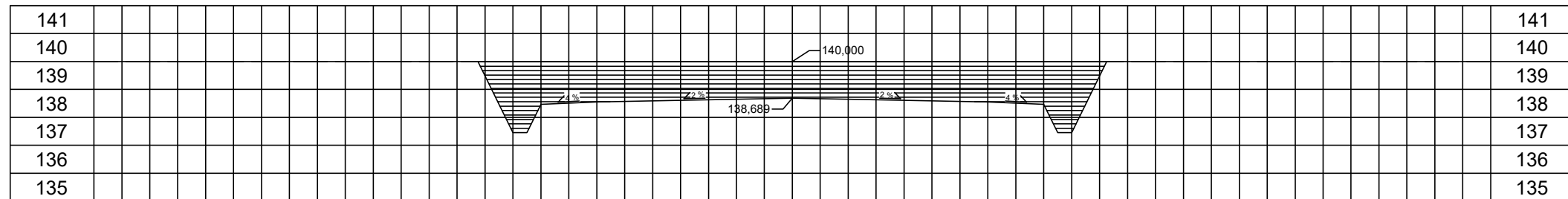

**STA 02+700**

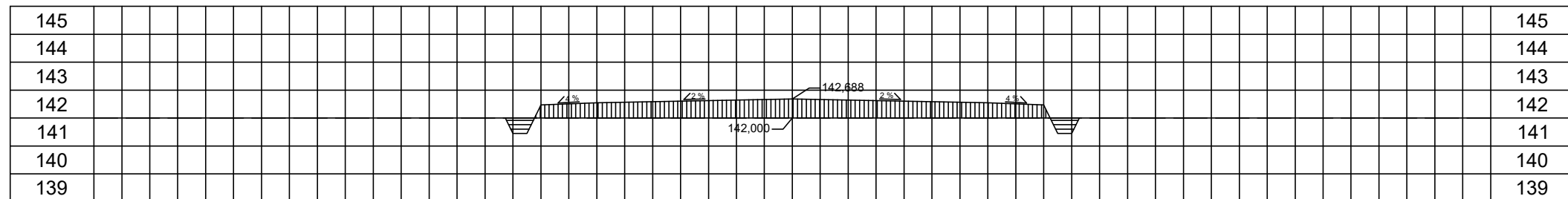

**STA 02+800**

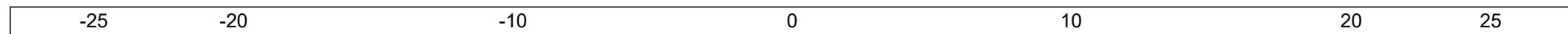
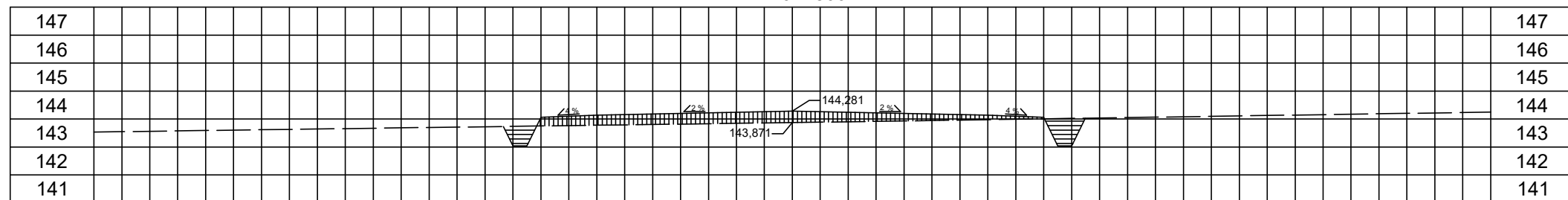

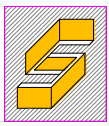

**PERENCANAAN GEOMETRIK DAN TEBAL PERKERASAN KAKU**  
**JALAN LINGKAR BARAT SP. SPORT CENTER - BUKIT SULAP**  
**KOTA LUBUKLINGGAU STA 00+000 - 08+150**  
**PROVINSI SUMATERA SELATAN**

**PEMBIMBING I**  
 Mahmuda, S.T., M.T.  
 NIP. 196207011989032062

**PEMBIMBING II**  
 Drs. Bambang H. Fuady, S.T., M.M., M.T.  
 NIP. 195807161986031004

**DIGAMBAR OLEH :**  
 Dwi Andra Octoni Darma  
 NIM. 061940111879

**DIGAMBAR OLEH :**  
 Rangga Isnanda  
 NIM. 061940111891

**JUDUL GAMBAR**  
 POTONGAN MELINTANG

**NOMOR GAMBAR**  
 JUMLAH GAMBAR

**SKALA**  
 1 : 200

**POLITEKNIK**  
**NEGERI SRIWIJAYA**  
**PALEMBANG**

STA 02+900

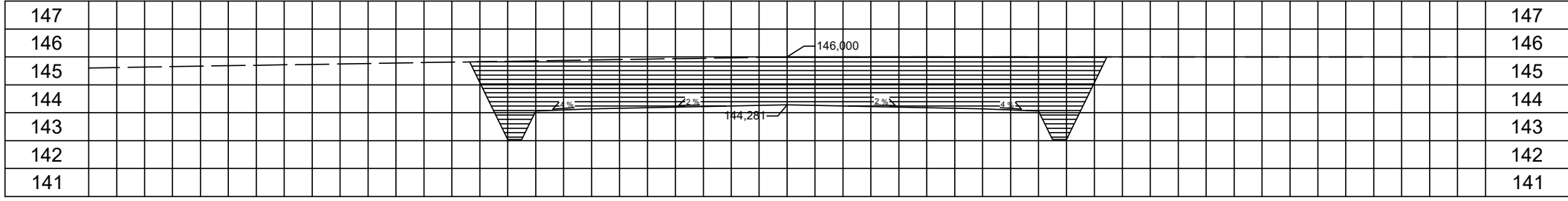

STA 03+000

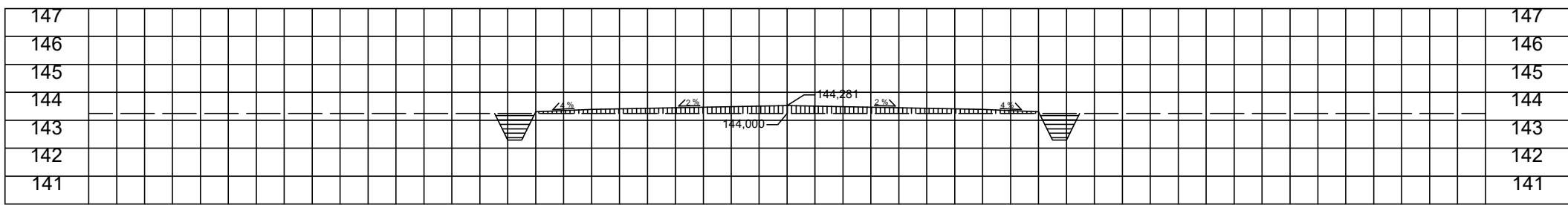

STA 03+100

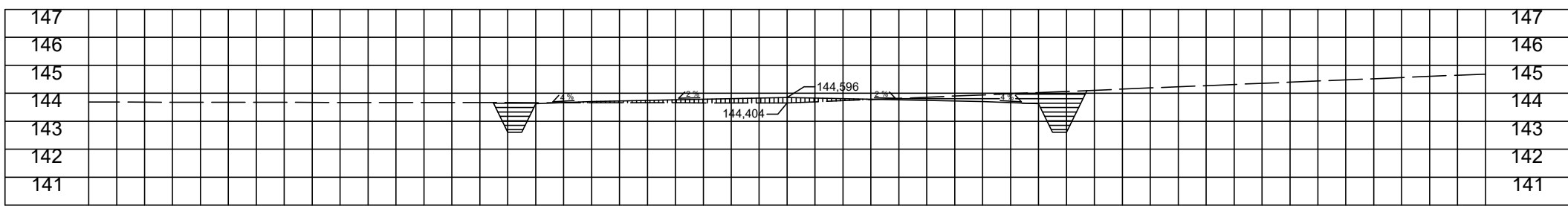

STA 03+200

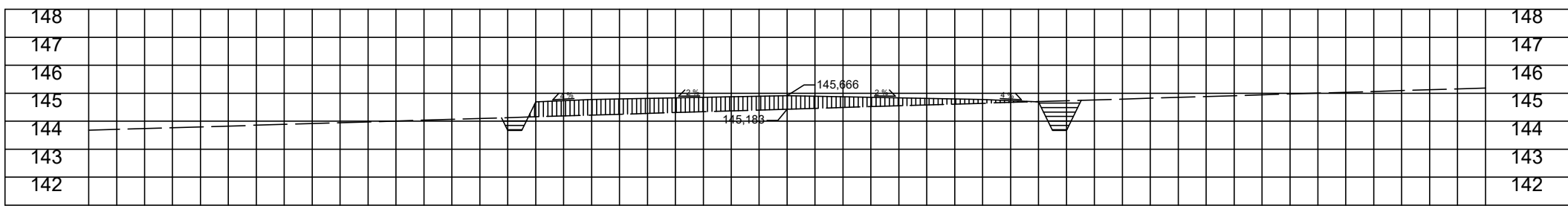

STA 03+300

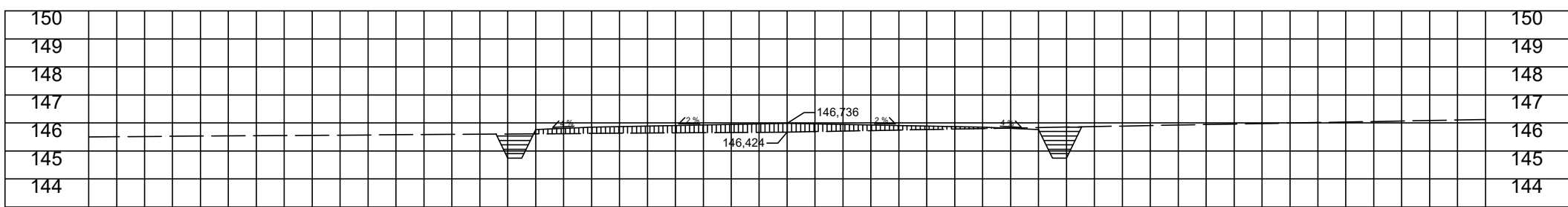

-25      -20      -10      0      10      20      25



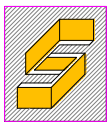

**PERENCANAAN GEOMETRIK DAN TEBAL PERKERASAN KAKU**  
**JALAN LINGKAR BARAT SP. SPORT CENTER - BUKIT SULAP**  
**KOTA LUBUKLINGGAU STA 00+000 - 08+150**  
**PROVINSI SUMATERA SELATAN**

PEMBIMBING I  
 Mahmuda, S.T., M.T.  
 NIP. 196207011989032062

PEMBIMBING II  
 Drs. Bambang H. Fuady, S.T., M.M., M.T.  
 NIP. 195807161986031004

DIGAMBAR OLEH :  
 Dwi Andra Octoni Darma  
 NIM. 061940111879

JUDUL GAMBAR  
 POTONGAN MELINTANG

NOMOR GAMBAR  
 JUMLAH GAMBAR

SKALA  
 1 : 200

**POLITEKNIK**  
**NEGERI SRIWIJAYA**  
**PALEMBANG**

STA 03+400

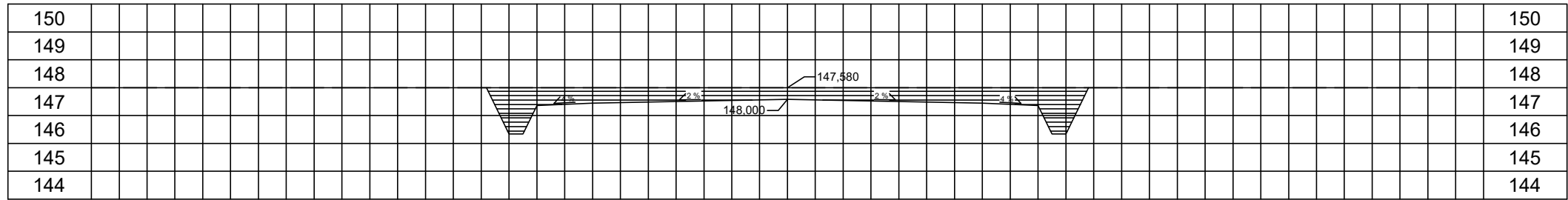

STA 03+500

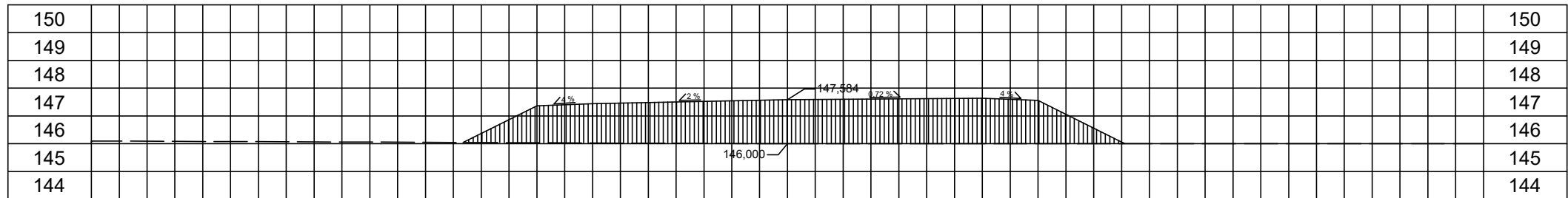

STA 03+600

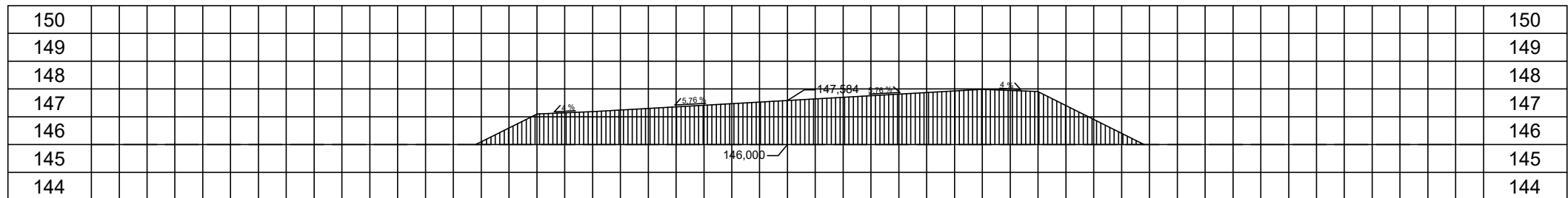

STA 03+635,78

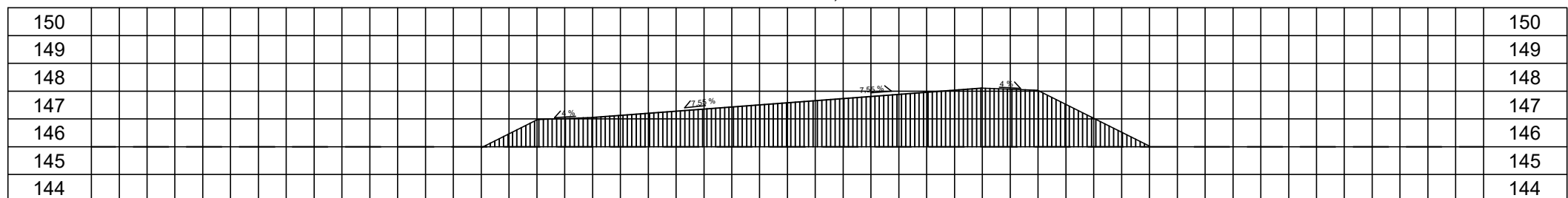

STA 03+700

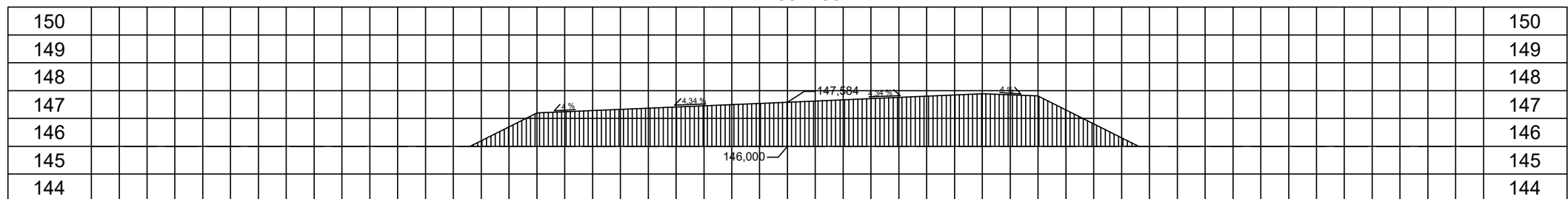

-25      -20      -10      0      10      20      25

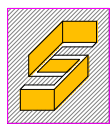

**PERENCANAAN GEOMETRIK DAN TEBAL PERKERASAN KAKU  
JALAN LINGKAR BARAT SP. SPORT CENTER - BUKIT SULAP  
KOTA LUBUKLINGGAU STA 00+000 - 08+150  
PROVINSI SUMATERA SELATAN**

PEMBIMBING I  
  
Mahmuda, S.T., M.T.  
NIP. 196207011989032062

PEMBIMBING II  
  
Drs. Bambang H. Fuady, S.T., M.M., M.T.  
NIP. 195807161986031004

DIGAMBAR OLEH :  
  
Dwi Andra Octoni Darma  
NIM. 061940111879

JUDUL GAMBAR  
  
POTONGAN MELINTANG

NOMOR GAMBAR  
  
JUMLAH GAMBAR

SKALA  
  
1 : 200

**POLITEKNIK  
NEGERI SRIWIJAYA  
PALEMBANG**

STA 03+800

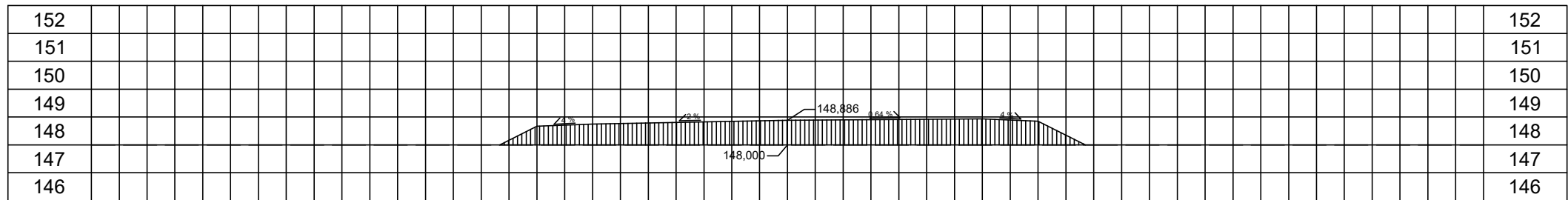

STA 03+900

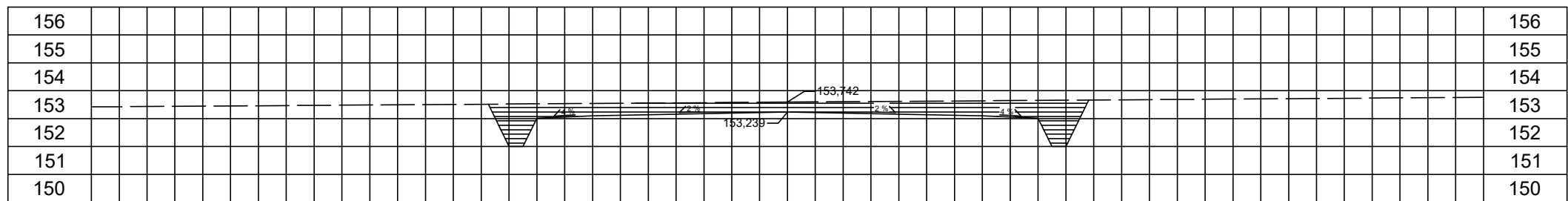

STA 04+000

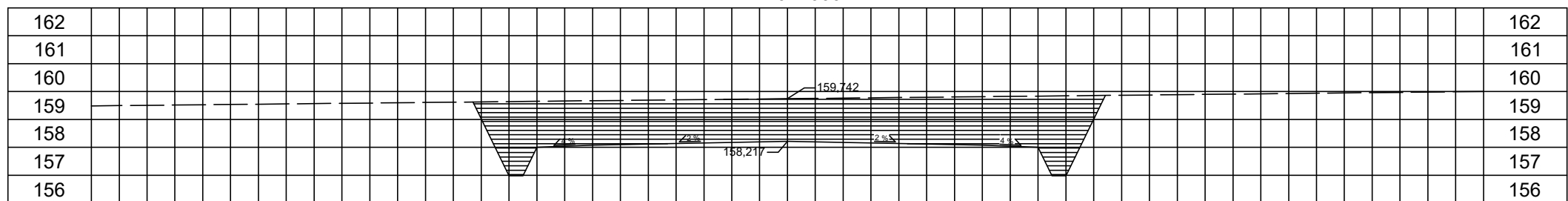

STA 04+100

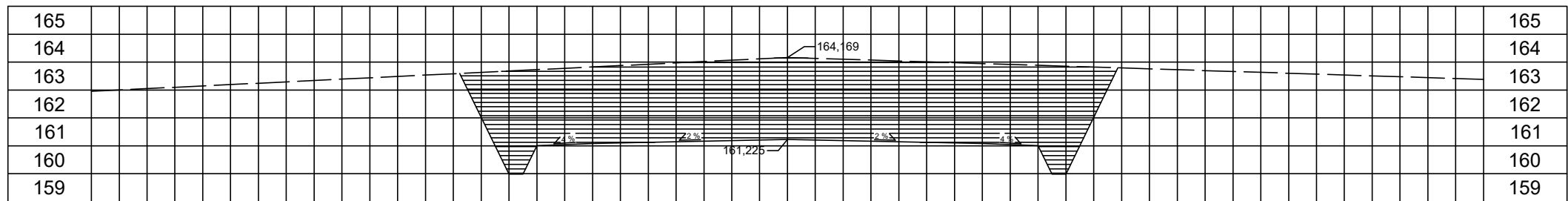

STA 04+200

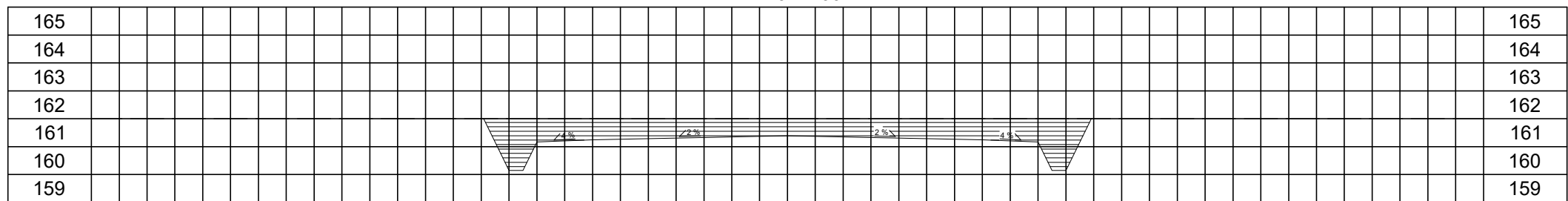

-25      -20      -10      0      10      20      25

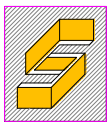

STA 04+300

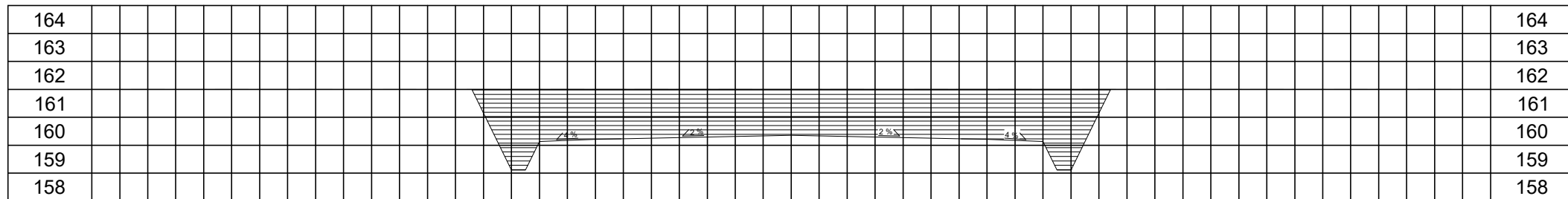

STA 04+400

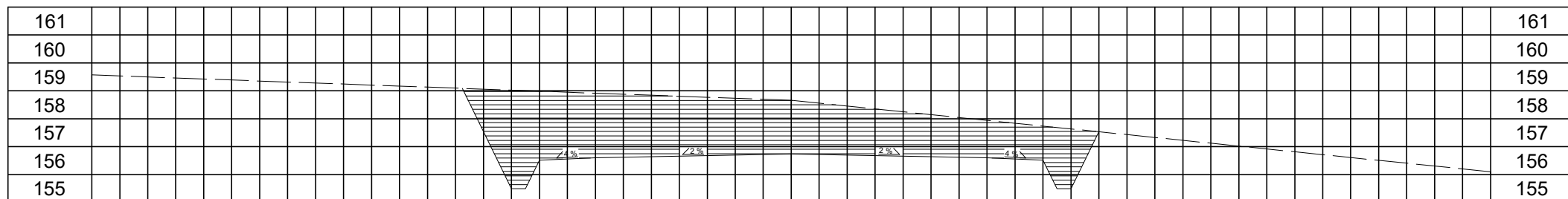

STA 04+500

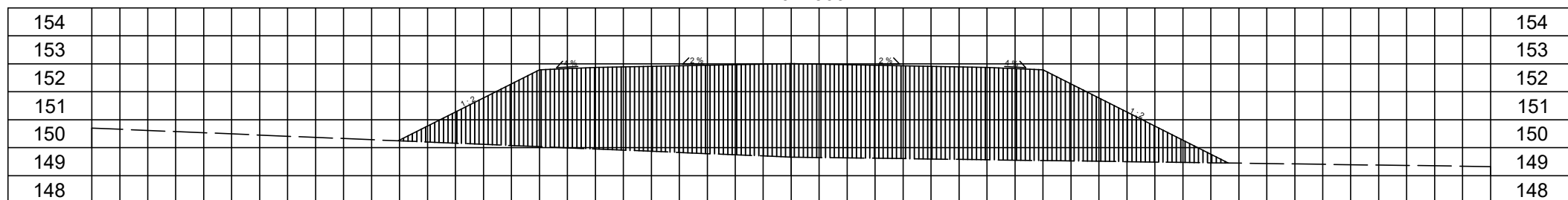

STA 04+588,432

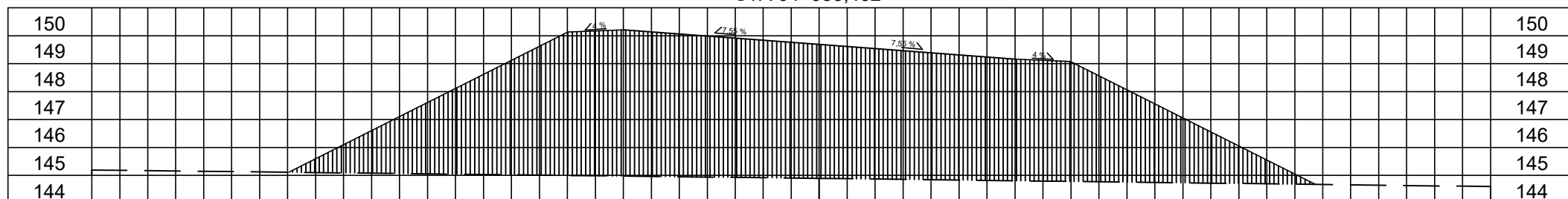

STA 04+600

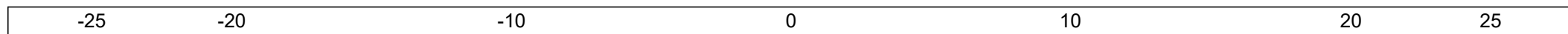
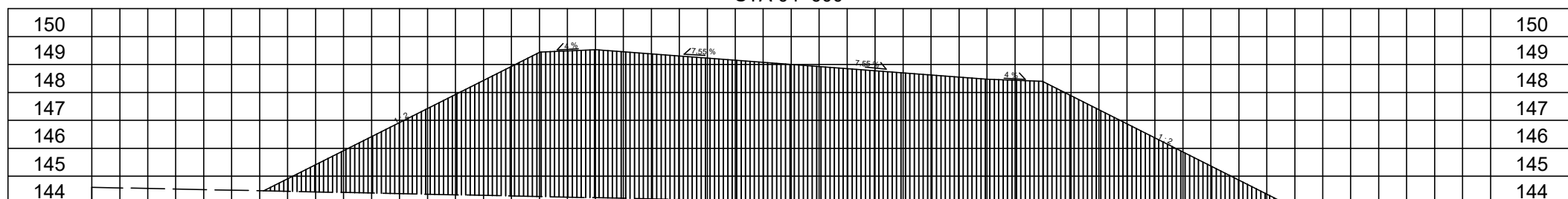

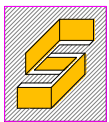

STA 04+700

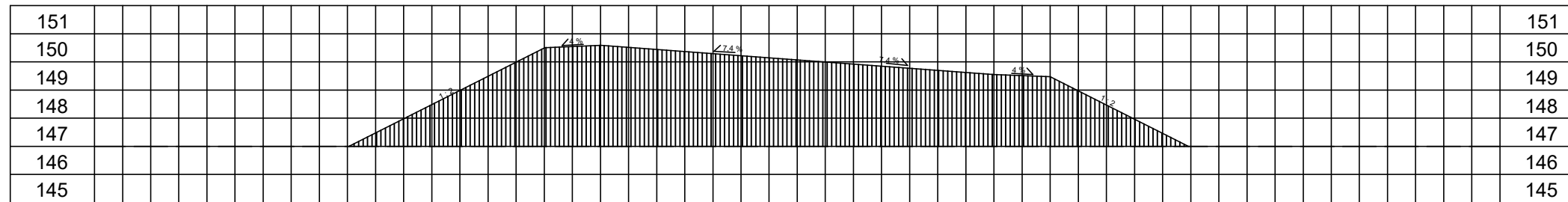

STA 04+800

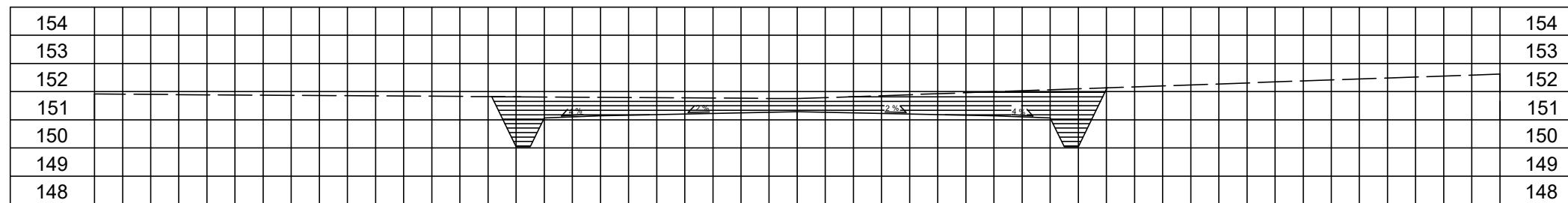

STA 04+900

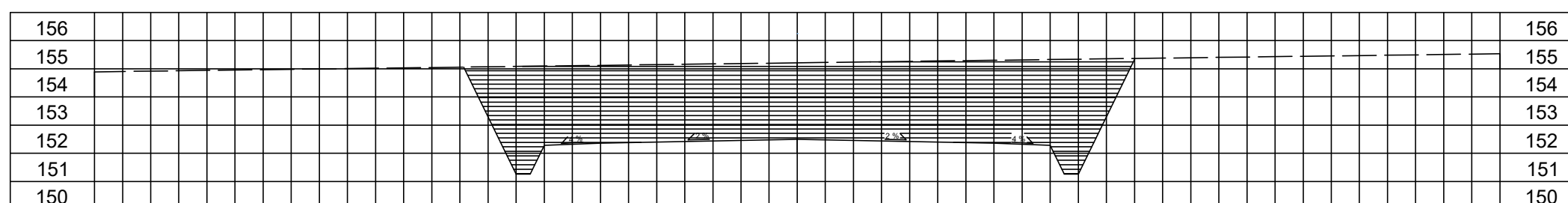

STA 05+000

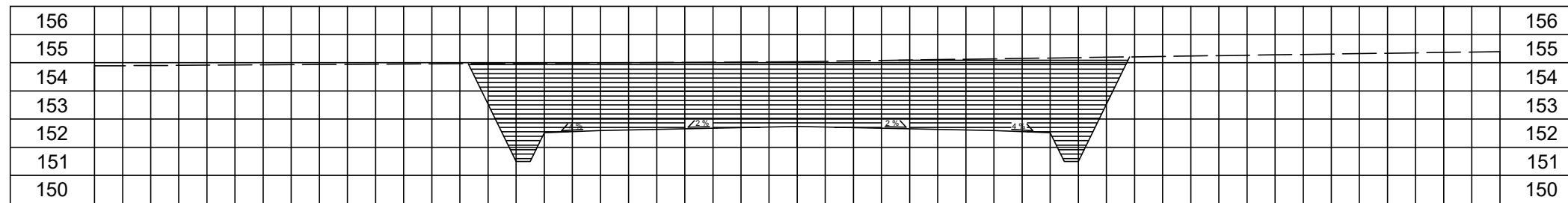

STA 05+100

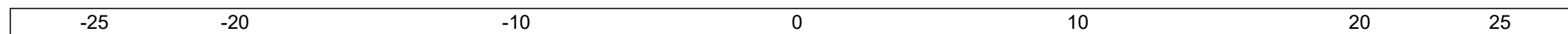
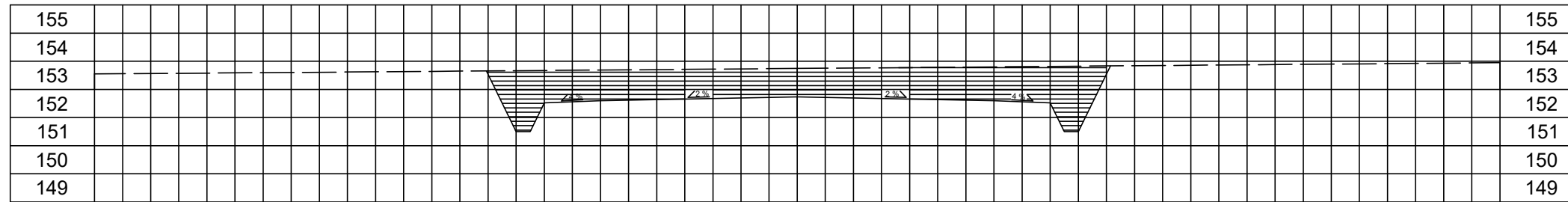

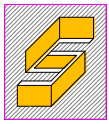

**PERENCANAAN GEOMETRIK DAN TEBAL PERKERASAN KAKU**  
**JALAN LINGKAR BARAT SP. *SPORT CENTER* - BUKIT SULAP**  
**KOTA LUBUKLINGGAU STA 00+000 - 08+150**  
**PROVINSI SUMATERA SELATAN**

PEMBIMBING I

PEMBIMBING II

DIGAMBAR OLEH :

JUDUL GAMBAR

NOMOR GAMBAR

SKALA

Mahmuda, S.T., M.T.  
NIP. 196207011989032062

Drs. Bambang H. Fuady, S.T., M.M., M.T.  
NIP. 195807161986031004

Dwi Andra Octoni Darma  
NIM. 061940111879

Rangga Isnanda  
NIM. 061940111891

POTONGAN MELINTANG

JUMLAH GAMBAR

1 : 200

**POLITEKNIK**  
**NEGERI SRIWIJAYA**  
**PALEMBANG**

STA 05+200

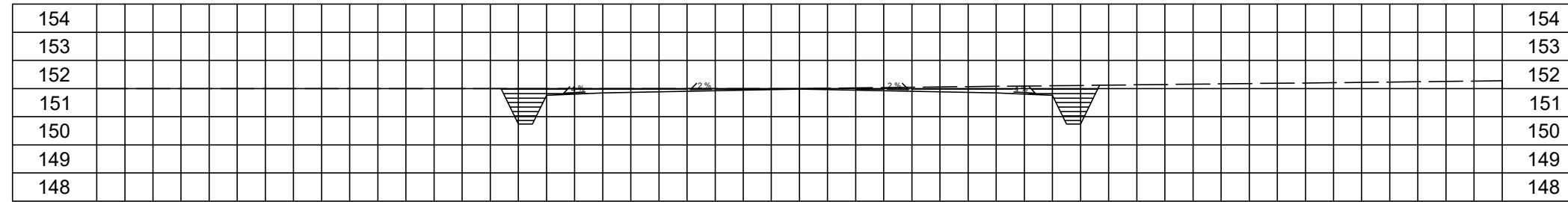

STA 05+300

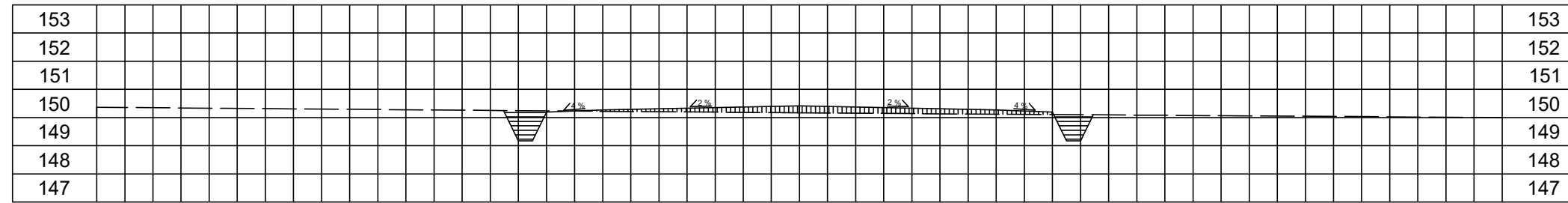

STA 05+400

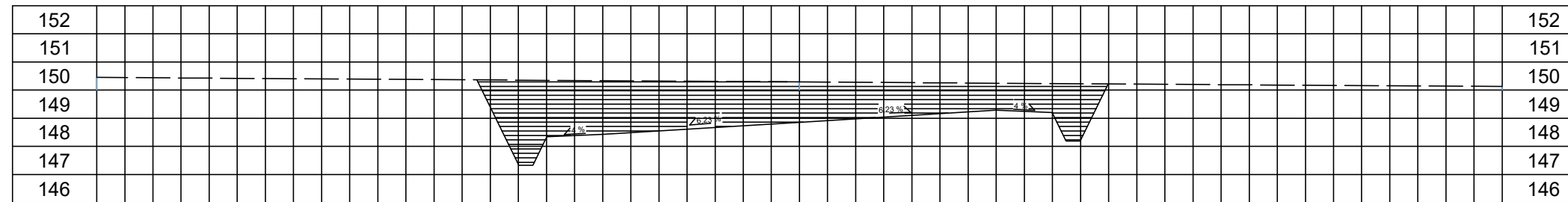

STA 05+541,032

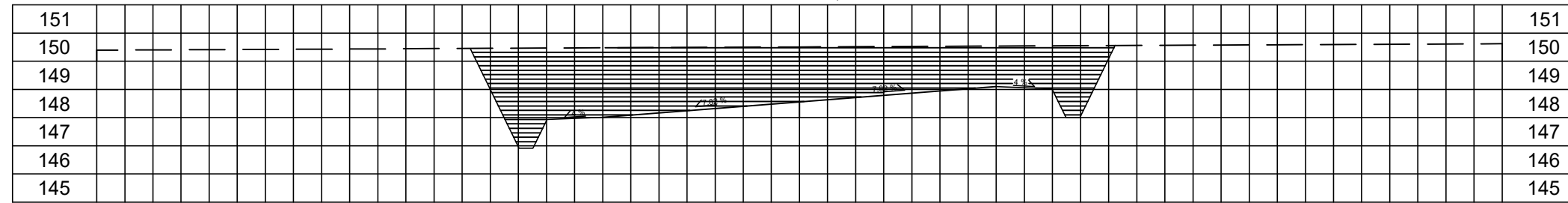

STA 05+500

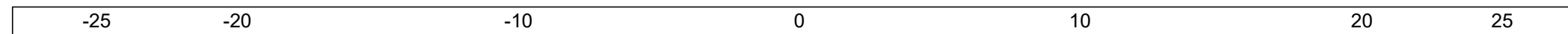
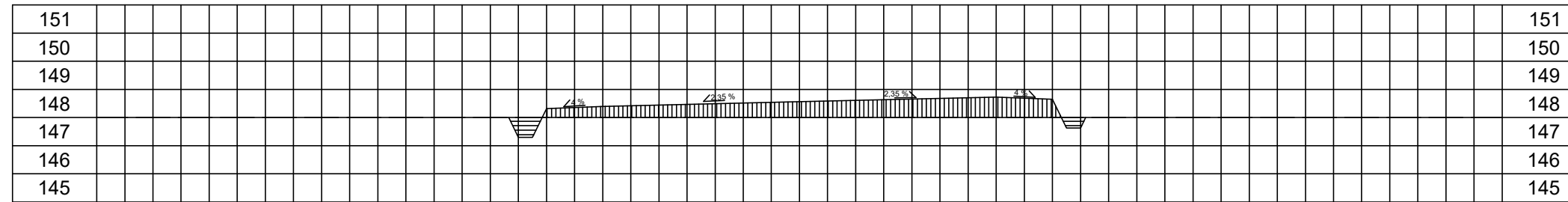



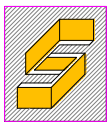

**PERENCANAAN GEOMETRIK DAN TEBAL PERKERASAN KAKU  
JALAN LINGKAR BARAT SP. SPORT CENTER - BUKIT SULAP  
KOTA LUBUKLINGGAU STA 00+000 - 08+150  
PROVINSI SUMATERA SELATAN**

PEMBIMBING I  
  
Mahmuda, S.T., M.T.  
NIP. 196207011989032062

PEMBIMBING II  
  
Drs. Bambang H. Fandy, S.T., M.M., M.T.  
NIP. 195807161986031004

DIGAMBAR OLEH :  
  
Dwi Andra Octoni Darma  
NIM. 061940111879  
  
Rangga Isnanda  
NIM. 061940111891

JUDUL GAMBAR  
  
POTONGAN MELINTANG

NOMOR GAMBAR  
  
JUMLAH GAMBAR

SKALA  
  
1 : 200

**POLITEKNIK  
NEGERI SRIWIJAYA  
PALEMBANG**

STA 05+600

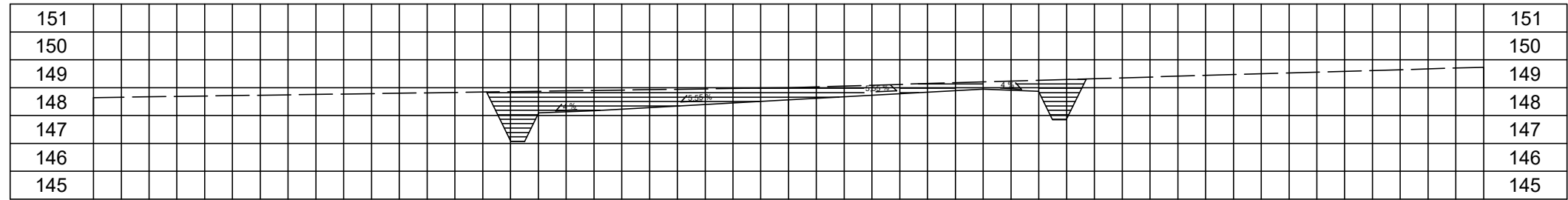

STA 05+700

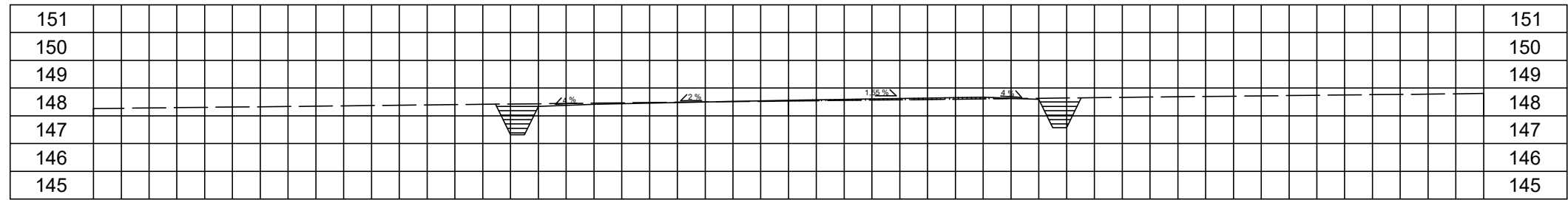

STA 05+800

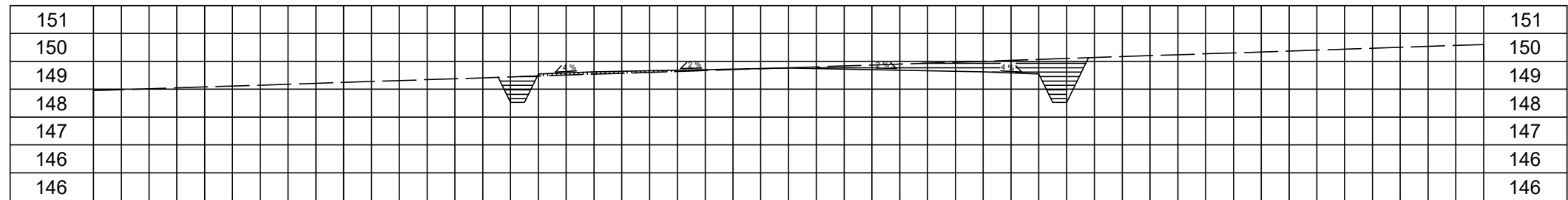

STA 05+900

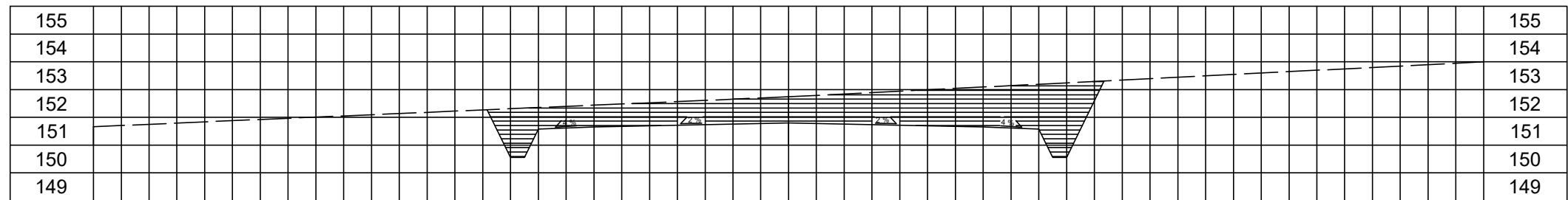

STA 06+000

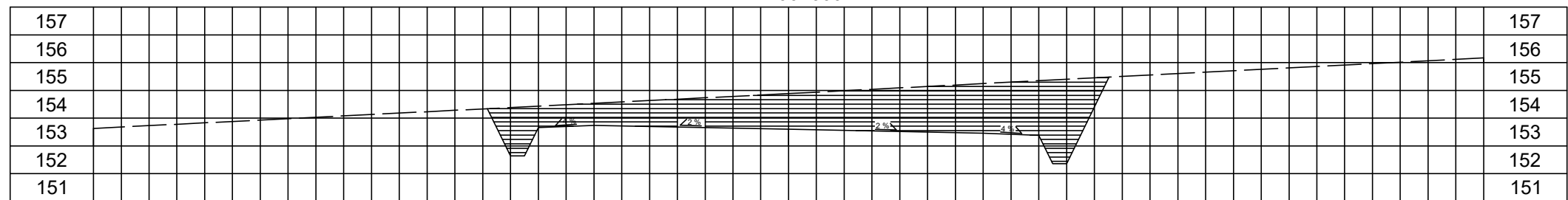

-25      -20      -10      0      10      20      25

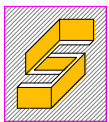

**PERENCANAAN GEOMETRIK DAN TEBAL PERKERASAN KAKU  
JALAN LINGKAR BARAT SP. SPORT CENTER - BUKIT SULAP  
KOTA LUBUKLINGGAU STA 00+000 - 08+150  
PROVINSI SUMATERA SELATAN**

PEMBIMBING I  
  
Mahmuda, S.T., M.T.  
NIP. 196207011989032062

PEMBIMBING II  
  
Drs. Bambang H. Fuady, S.T., M.M., M.T.  
NIP. 195807161986031004

DIGAMBAR OLEH :  
  
Dwi Andra Octoni Darma  
NIM. 061940111879  
  
Rangga Isnanda  
NIM. 061940111891

JUDUL GAMBAR  
  
POTONGAN MELINTANG

NOMOR GAMBAR  
  
JUMLAH GAMBAR

SKALA  
  
1 : 200

**POLITEKNIK  
NEGERI SRIWIJAYA  
PALEMBANG**

STA 06+100

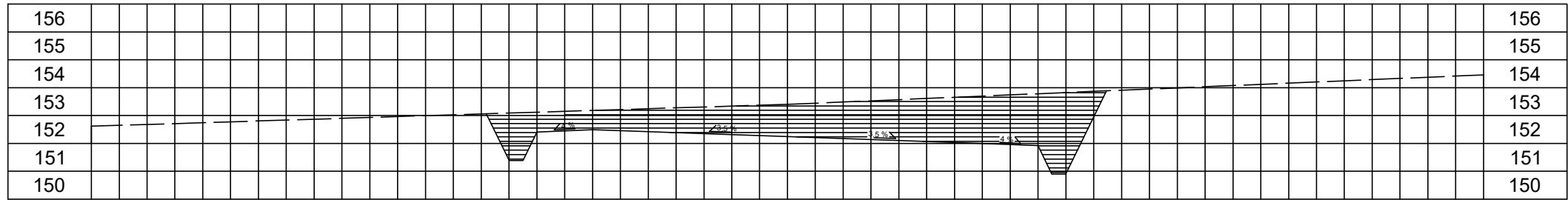

STA 06+200

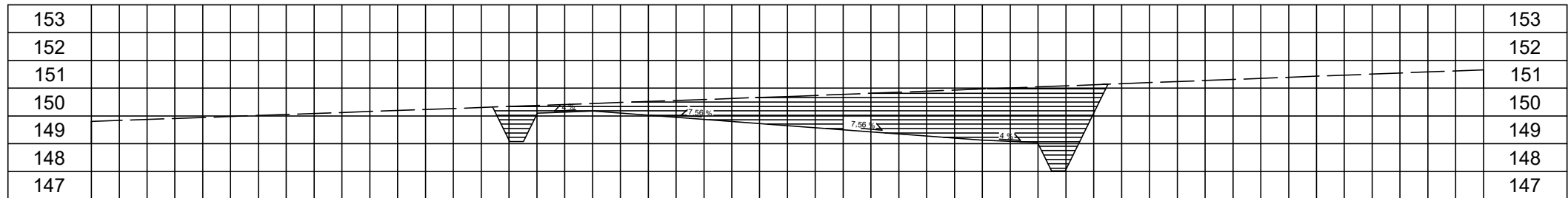

STA 06+208,382

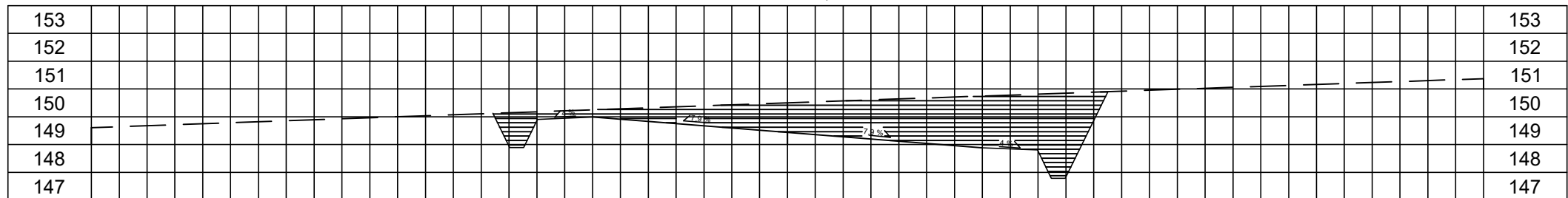

STA 06+300



STA 06+400

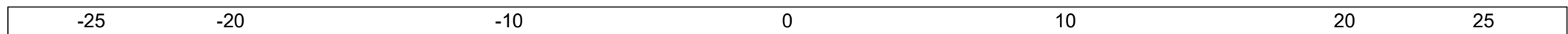
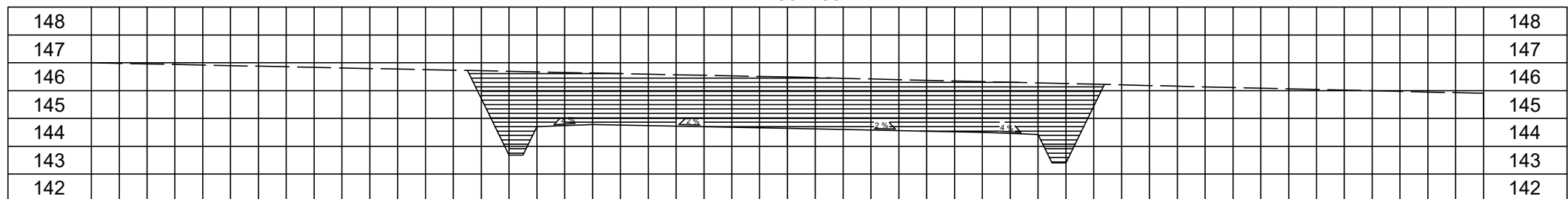

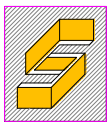

**PERENCANAAN GEOMETRIK DAN TEBAL PERKERASAN KAKU**  
**JALAN LINGKAR BARAT SP. SPORT CENTER - BUKIT SULAP**  
**KOTA LUBUKLINGGAU STA 00+000 - 08+150**  
**PROVINSI SUMATERA SELATAN**

PEMBIMBING I  
 Mahmuda, S.T., M.T.  
 NIP. 196207011989032062

PEMBIMBING II  
 Drs. Bambang H. Fandy, S.T., M.M., M.T.  
 NIP. 195807161986031004

DIGAMBAR OLEH :  
 Dwi Andra Octoni Darma  
 NIM. 061940111879  
 Rangga Isnanda  
 NIM. 061940111891

JUDUL GAMBAR  
 POTONGAN MELINTANG

NOMOR GAMBAR  
 JUMLAH GAMBAR

SKALA  
 1 : 200

**POLITEKNIK**  
**NEGERI SRIWIJAYA**  
**PALEMBANG**

STA 06+500

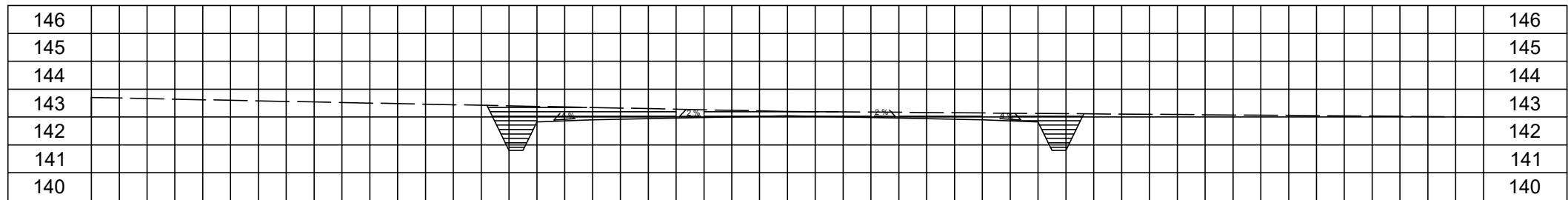

STA 06+600

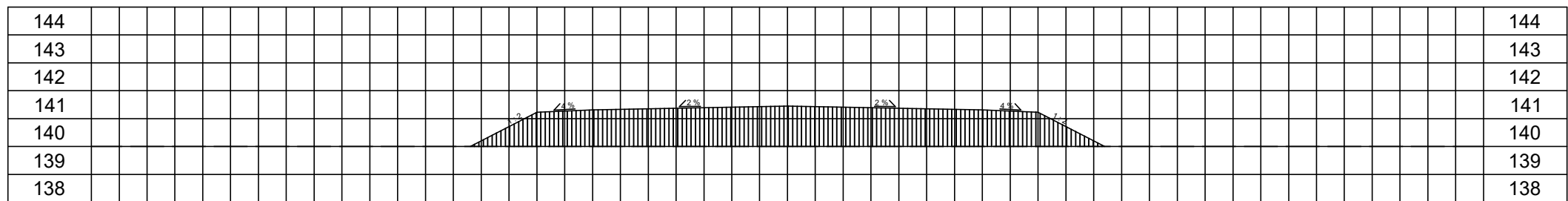

STA 06+700

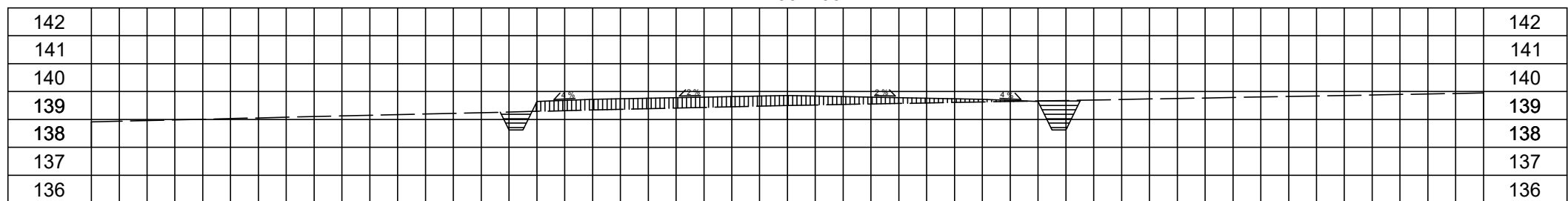

STA 06+800

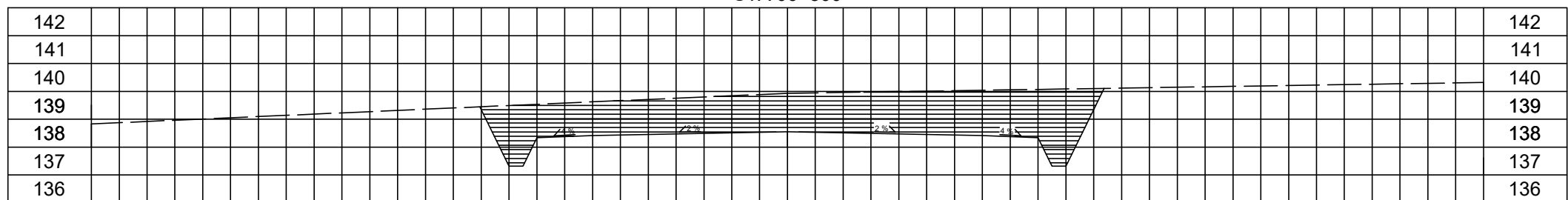

STA 06+900

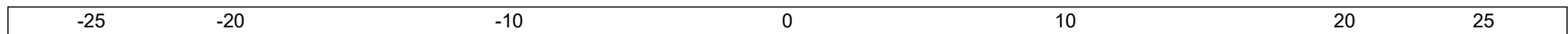
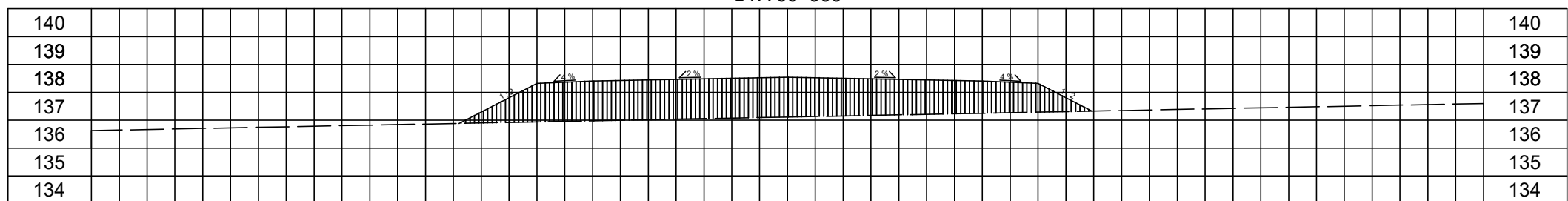

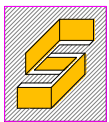

**PERENCANAAN GEOMETRIK DAN TEBAL PERKERASAN KAKU  
JALAN LINGKAR BARAT SP. SPORT CENTER - BUKIT SULAP  
KOTA LUBUKLINGGAU STA 00+000 - 08+150  
PROVINSI SUMATERA SELATAN**

PEMBIMBING I  
  
Mahmuda, S.T., M.T.  
NIP. 196207011989032062

PEMBIMBING II  
  
Drs. Bambang H. Fandy, S.T., M.M., M.T.  
NIP. 195807161986031004

DIGAMBAR OLEH :  
  
Dwi Andra Octoni Darma  
NIM. 061940111879

JUDUL GAMBAR  
  
POTONGAN MELINTANG

NOMOR GAMBAR  
  
JUMLAH GAMBAR

SKALA  
  
1 : 200

**POLITEKNIK  
NEGERI SRIWIJAYA  
PALEMBANG**

STA 07+000

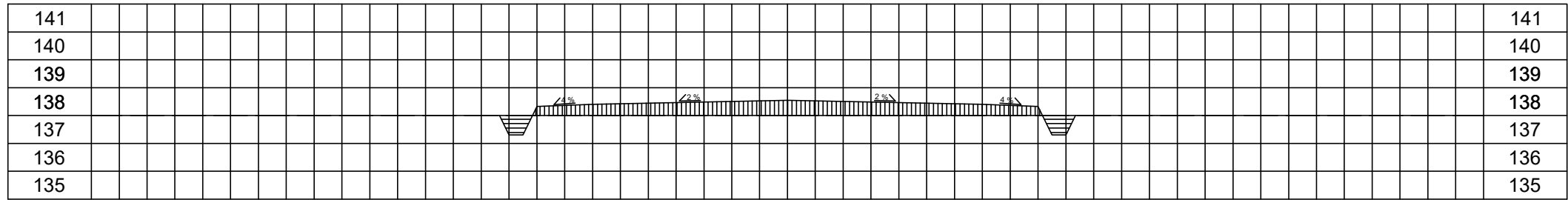

STA 07+100

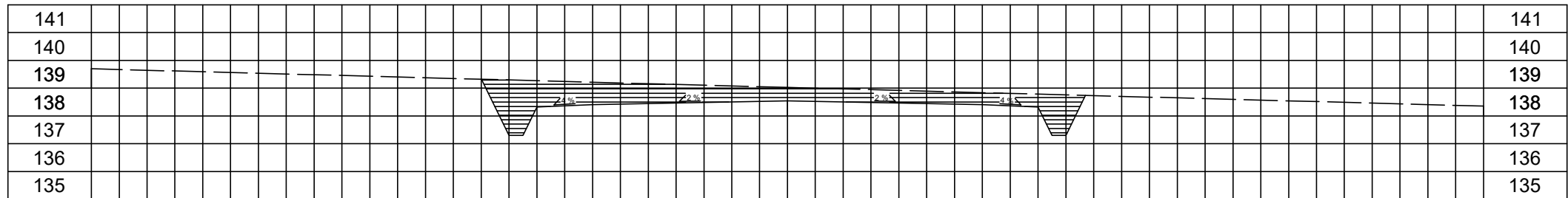

STA 07+200



STA 07+300

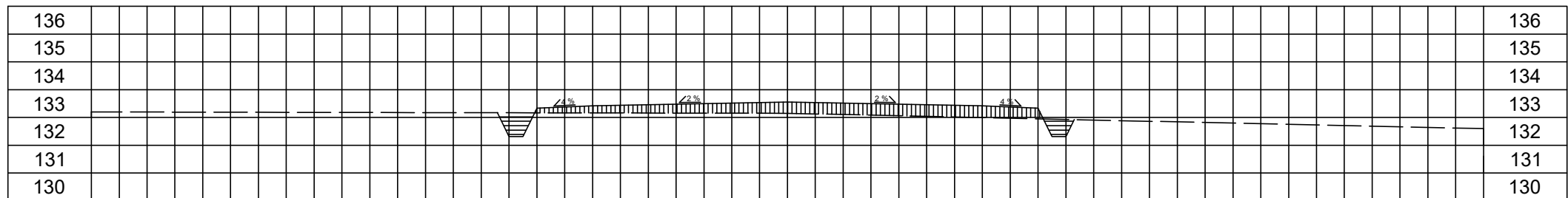

STA 07+400

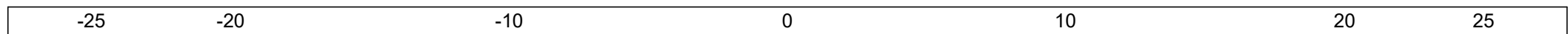
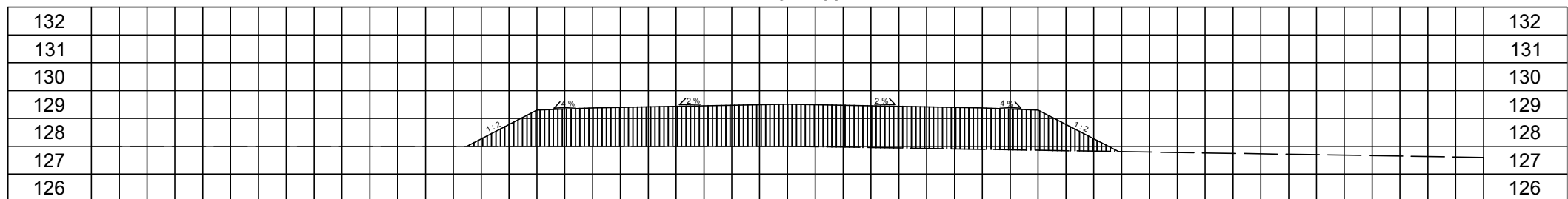







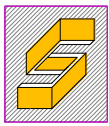

PERENCANAAN GEOMETRIK DAN TEBAL PERKERASAN KAKU  
JALAN LINGKAR BARAT SP. *SPORT CENTER* - BUKIT SULAP  
KOTA LUBUKLINGGAU STA 00+000 - 08+150  
PROVINSI SUMATERA SELATAN

PEMBIMBING I

Mahmuda, S.T., M.T.  
NIP. 196207011989032002

PEMBIMBING II

Drs. Bambang H. Fandy, S.T., M.M., M.T.  
NIP. 195807161986031004

DIGAMBAR OLEH :

Dwi Andra Octoni Darma  
NIM. 061940111879

Rangga Ismunda  
NIM. 061940111894

JUDUL GAMBAR

NWP

NOMOR GAMBAR

JUMLAH GAMBAR

SKALA

POLITEKNIK  
NEGERI SRIWIJAYA  
PALEMBANG

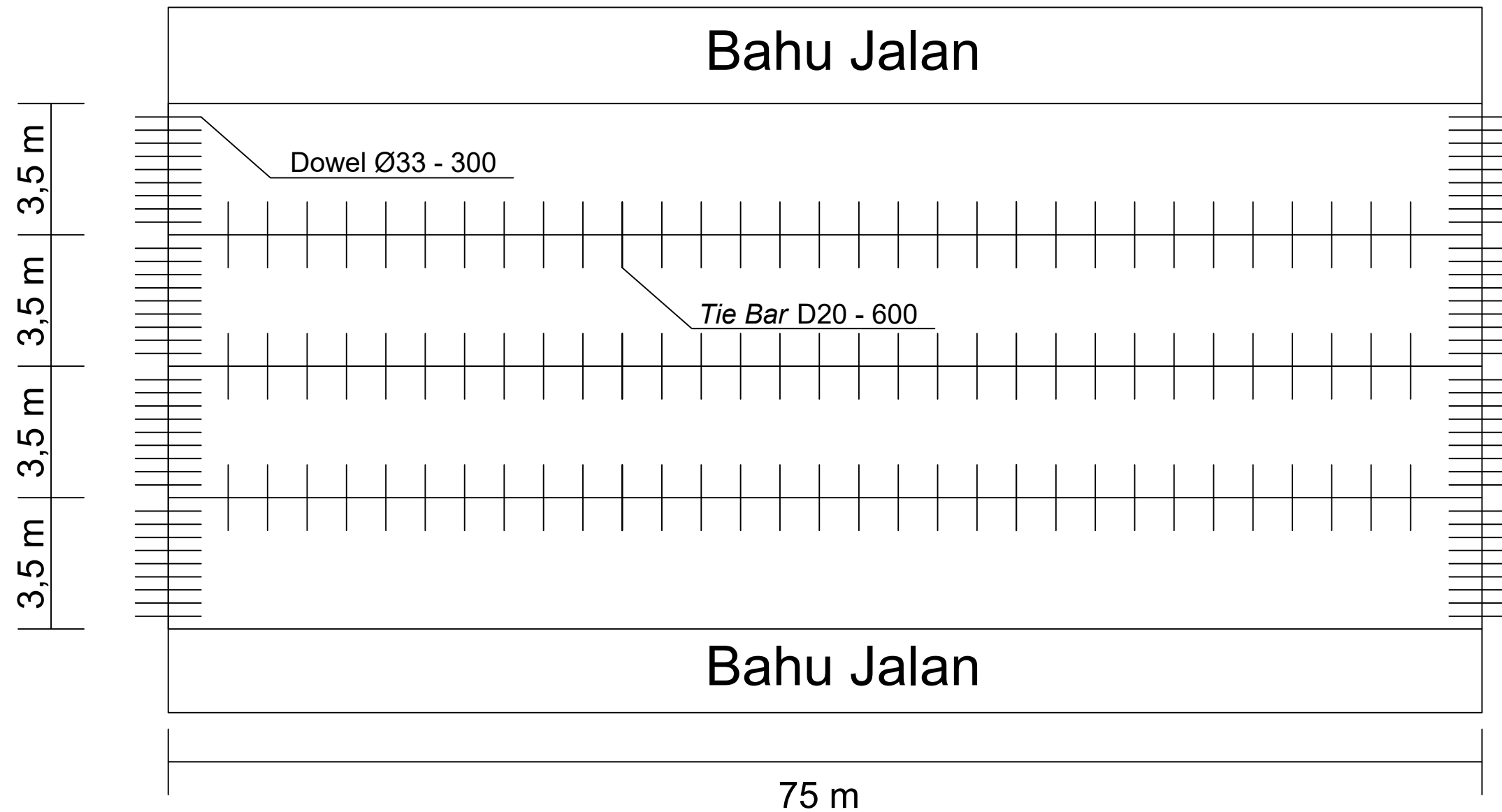

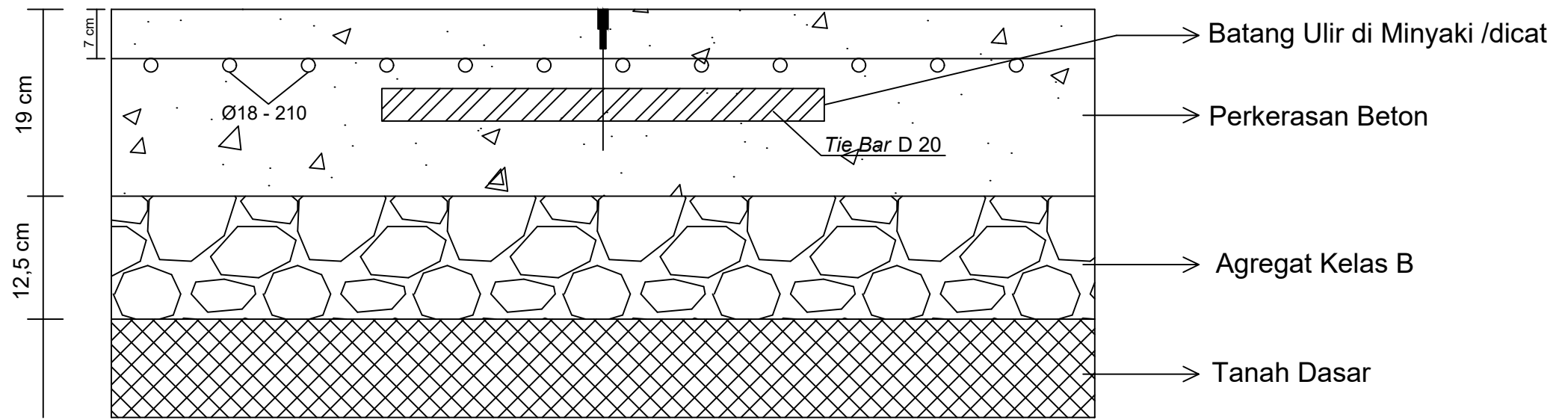
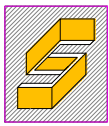

Gambar Penulangan Memanjang dan Sambungan Tie bar

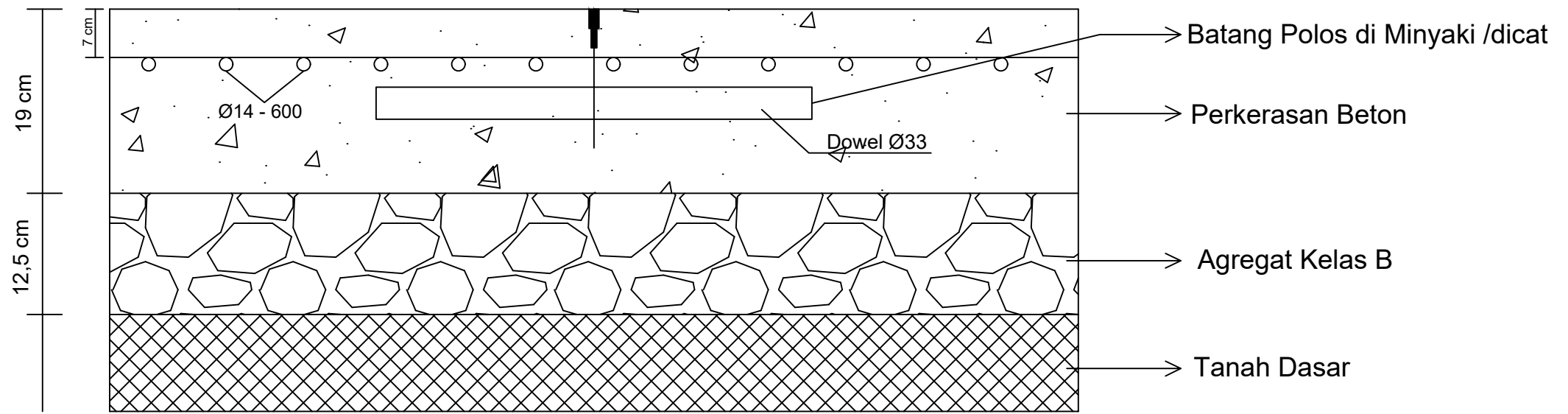

Gambar Penulangan Melintang dan Sambungan Dowel

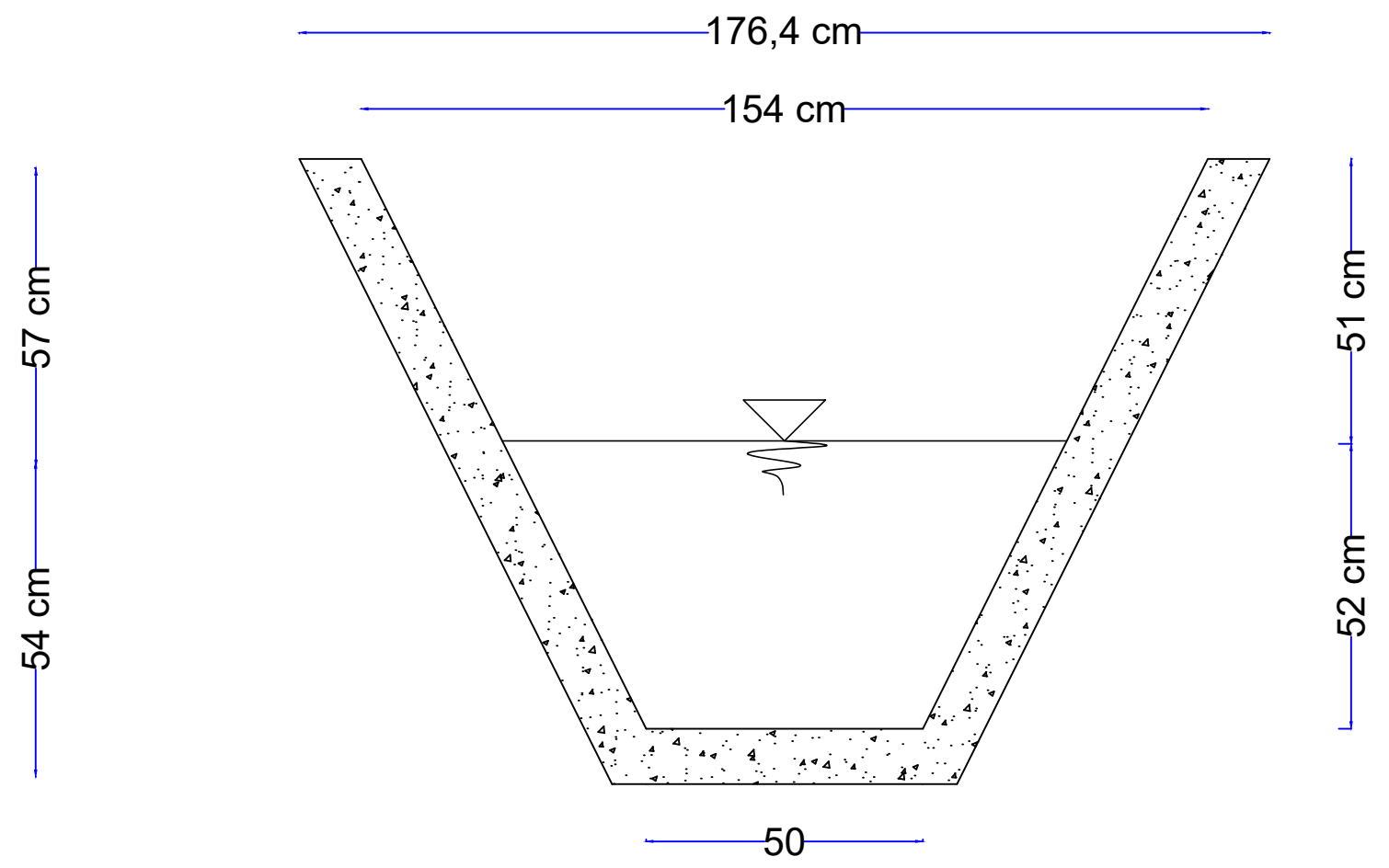
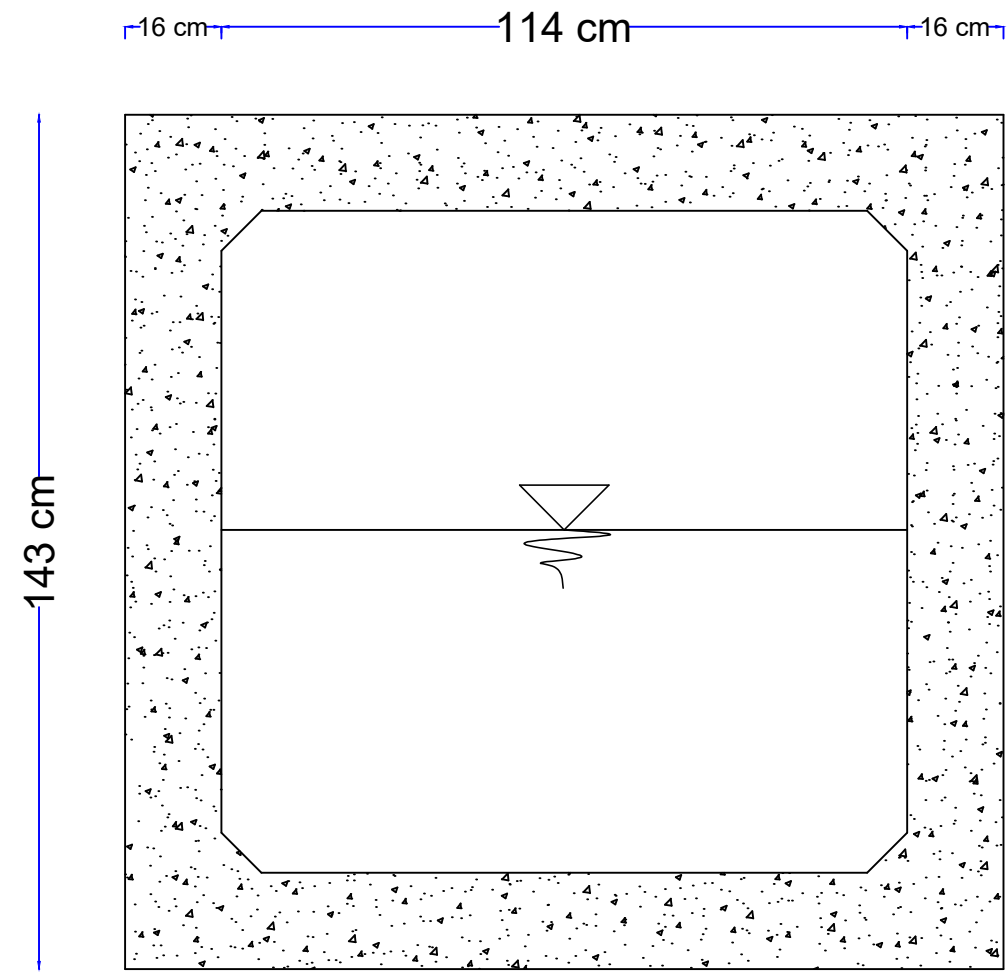
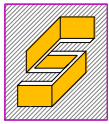

# DESAIN DRAINASE DAN *BOX CULVERT*

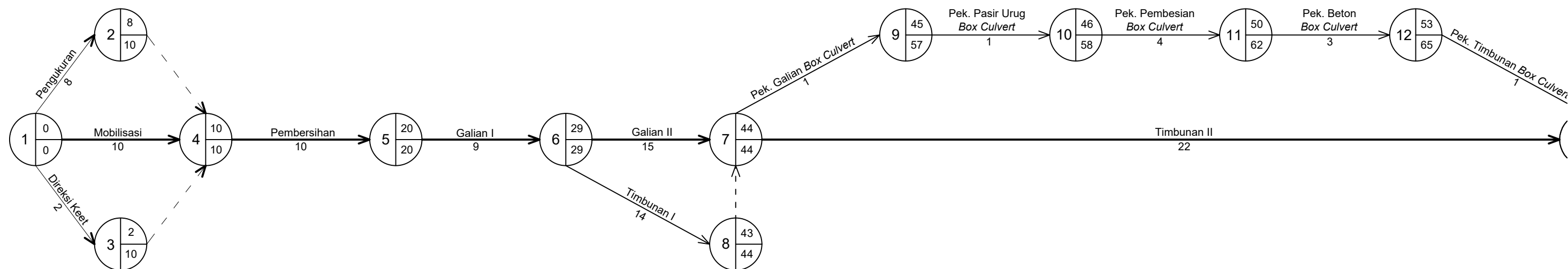
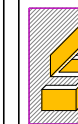
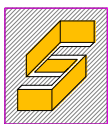

Jalur Kritis = 1 - 4 - 5 - 6 - 7 - 13 - 16 - 17 - 18 - 21 - 23 - 24 - 25

**Keterangan :**

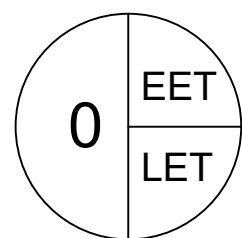

- EET = EARLIEST EVENT TIME ( WAKTU PENYELESAIAN PALING AWAL )
- LET = LATEST EVENT TIME ( WAKTU PENYELESAIAN PALING AKHIR )
- 0 = LATEST EVENT TIME ( WAKTU PENYELESAIAN PALING AKHIR )

- $\longrightarrow$  = JALUR KRITIS, JALUR YANG MENUNJUKKAN PEKERJAAN YANG TIDAK BOLEH TERLAMBAT SATU DENGAN YANG LAIN
- $\longrightarrow$  = KEGIATAN PEKERJAAN
- $\dashrightarrow$  = KEGIATAN SEMU ( DUMMY ), MENYATAKAN BAHWA ANTARA KEGIATAN SATU DENGAN YANG LAINNYA MASIH SALING KETERGANTUNGAN



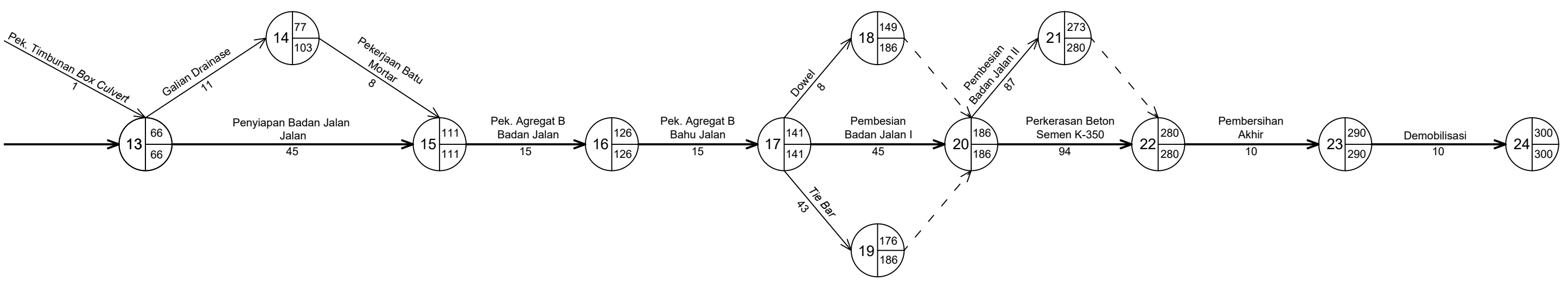
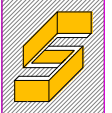



# AN KURVA S

## T CENTER - BUKIT SULAP KOTA LUBUKLINGGAU

