

CURRICULUM VITAE

NAMA LENGKAP : ADELIA AGATHA
NIM : 061940352351
TEMPAT,TANGGAL LAHIR : PALEMBANG,28 DESEMBER 2001
ALAMAT : JL.KH AZHARI LR.SUNGAI AUR RT.027 9/10 ULU
TELEPON : 089647868646

RIWAYAT PENDIDIKAN

PENDIDIKAN	NAMA SEKOLAH	TAMAT TAHUN
SD	SD NEGERI 84 PALEMBANG	2013
SMP	SMP AZHARYAH PALEMBANG	2016
SMA	SMA NEGERI 19 PALEMBANG	2019

PENGALAMAN INTERNSHIP

NO	PENGALAMAN	TAHUN
1.	INTERNSHIP PARTICIPAN PT. ANGKASA PURA II KANTOR CABANG BANDAR UDARA SULTAN MAHMUD BADARUDDIN II PALEMBANG	2022

PENGALAMAN ORGANISASI

NO	PENGALAMAN	TAHUN
1.	ANGGOTA UKM SIMPONY	2019
2.	KADER PKK TIM PENDAMPING KELUARGA	2022
3.	KADER PKK KELURAHAN	2023
4.	DUTA GENRE KELURAHAN	2023

Semua data yang tercantum dalam Curriculum Vitae ini adalah benar dan dapat dipertanggung jawabkan.

Palembang Agustus 2023

(Adelia Agatha)



KEMENTERIAN PENDIDIKAN, KEBUDAYAAN,
RISET DAN TEKNOLOGI
POLITEKNIK NEGERI SRIWIJAYA
Jalan Srijaya Negara, Palembang 30139 Telp. 0711-353414
Laman: <http://polsri.ac.id>, Pos El : info@polsri.ac.id



KESEPAKATAN BIMBINGAN TUGAS AKHIR (TA)

Kami yang bertanda tangan dibawah ini,

Pihak Pertama

Nama : Adelia Agatha
NIM : 061940352351
Jurusan : Teknik Elektro
Program Studi : Sarjana Terapan Teknik Telekomunikasi

Pihak Kedua

Nama : Lindawati, S.T., M.T.I.
NIP : 197105282006042001
Jurusan : Teknik Elektro
Program Studi : Sarjana Terapan Teknik Telekomunikasi

Pada hari ini Selasa tanggal 9 Mei 2023 telah sepakat untuk melakukan konsultasi bimbingan Tugas Akhir (TA).

Konsultasi bimbingan sekurang- kurangnya 1 (satu) kali dalam satu minggu. Pelaksanaan bimbingan pada setiap hari pukul..... tempat di Politeknik Negeri Sriwijaya.

Demikianlah kesepakatan ini dibuat dengan penuh kesadaran guna kelancaran penyelesaian Tugas Akhir.

Pihak Pertama

(Adelia Agatha)
NIM. 061940352351

Palembang, 2023
Pihak Kedua

(Lindawati, S.T., M.T.I.)
NIP. 197105282006042001

Mengetahui
Ketua Jurusan Teknik Elektro

(Ir. Iskandar Lutfi, M.T.)
NIP. 196502291991031002



KEMENTERIAN PENDIDIKAN, KEBUDAYAAN,
RISET DAN TEKNOLOGI
POLITEKNIK NEGERI SRIWIJAYA
Jalan Srijaya Negara, Palembang 30139 Telp. 0711-353414
Laman: <http://polsri.ac.id>, Pos El : info@polsri.ac.id



KESEPAKATAN BIMBINGAN TUGAS AKHIR (TA)

Kami yang bertanda tangan dibawah ini,

Pihak Pertama

Nama : Adelia Agatha
NIM : 061940352351
Jurusan : Teknik Elektro
Program Studi : Sarjana Terapan Teknik Telekomunikasi

Pihak Kedua

Nama : Sarjana, S.T., M.kom
NIP : 197406022005012002
Jurusan : Teknik Elektro
Program Studi : Sarjana Terapan Teknik Telekomunikasi

Pada hari ini Selasa tanggal 9 Mei 2023 telah sepakat untuk melakukan konsultasi bimbingan Tugas Akhir (TA).

Konsultasi bimbingan sekurang- kurangnya 1 (satu) kali dalam satu minggu. Pelaksanaan bimbingan pada setiap hari Selasa pukul 11:00 tempat di Politeknik Negeri Sriwijaya.

Demikianlah kesepakatan ini dibuat dengan penuh kesadaran guna kelancaran penyelesaian Tugas Akhir.

Pihak Pertama

(Adelia Agatha)
NIM. 061940352351

Palembang,
Pihak Kedua

2023

(Sarjana, S.T., M.kom)
NIP. 197406022005012002

Mengetahui
Ketua Jurusan Teknik Elektro

(Ir. Iskandar Lutfi, M.T.)
NIP. 196501291991031002



KEMENTERIAN PENDIDIKAN, KEBUDAYAAN,
RISET DAN TEKNOLOGI

POLITEKNIK NEGERI SRIWIJAYA
JURUSAN TEKNIK ELEKTRO

Jalan Srijaya Negara Bukit Besar - Palembang 30139 Telepon (0711) 353414
Laman : <http://polsri.ac.id>, POS El: info@polsri.ac.id



LEMBAR BIMBINGAN TUGAS AKHIR

Lembar : 1

Nama : Adelia Agatha
NIM : 061940352351
Jurusan/Program Studi : Teknik Elektro / Sarjana Terapan Teknik Telekomunikasi
Judul Tugas Akhir : *Tracking Hewan Peliharaan Menggunakan Message Queuing Telemetry Transport (MQTT) Berbasis Radio GPS*
Pembimbing I : Lindawati, S.T., M.T.I
NIP. 197105282006042001

No.	Tanggal	Uraian Bimbingan	Tanda Tangan Pembimbing
1.	14/3 2023	Konsultasi Progres TA	
2.	22/3 2023	Bab I dan Bab II	
3.	30/3 2023	Acc Bab I dan Bab II	
4.	10/4 2023	Bab III	
5.	19/4 2023	Acc Bab III	
6.	10/5 2023	Konsultasi Jurnal	
7.	19/5 2023	Acc Jurnal	

8.	20/6 2023	Ambil Data	Ld
9.	6/7 2023	Bab <u>IV</u>	Ld
10.	12/7 2023	Pengukuran Alat	Ld
11.	21/7 2023	Revisi Bab <u>IV</u>	Ld
12.	25/7 2023	Bab <u>V</u>	Ld
13.	31/7 2023	Acc Bab <u>V</u>	Ld
14.	4/8 2023	Submit Jurnal	Ld
15.	7/8 '23	Acc Sidang TA	Ld

Palembang, Agustus 2023
 Koordinator Program Studi
 Sarjana Terapan Teknik Telekomunikasi,

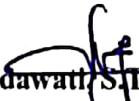
 Lindawati S.T., M.TI
 NIP. 197105282006042001



KEMENTERIAN PENDIDIKAN, KEBUDAYAAN,
RISET DAN TEKNOLOGI

POLITEKNIK NEGERI SRIWIJAYA
JURUSAN TEKNIK ELEKTRO

Jalan Srijaya Negara Bukit Besar - Palembang 30139 Telepon (0711) 353414
Laman : <http://polsri.ac.id>, POS El: info@polsri.ac.id











LEMBAR BIMBINGAN TUGAS AKHIR

Lembar : 1



Nama : Adelia Agatha
NIM : 061940352351
Jurusan/Program Studi : Teknik Elektro / Sarjana Terapan Teknik Telekomunikasi
Judul Tugas Akhir : *Tracking Hewan Peliharaan Menggunakan Message Queuing Telemetry Transport (MQTT) Berbasis Radio GPS*
Pembimbing II : Sarjana, S.T., M.Kom
NIP. 196911061995032001

No.	Tanggal	Uraian Bimbingan	Tanda Tangan Pembimbing
1.	4/5 2023	Konsul obyek yang mau di tracking (kucing)	
2.	25/5 2023	Jurnal / Penelitian sebelumnya	
3.	30/5 2023	Konsul tampilan GPS	
4.	5/6 2023	test alat menggunakan SIM 800	
5.	9/6 2023	Longitude Belum akurat	
6.	20/6 2023	test alat ke II, titik koordinat, sdh selesai alat 100%	
7.	26/6 2023	Bab III Acc, Lanjut Bab IV	

8.	2/9 2023	Perbaikan Bab <u>IV</u>	
9.	6/9 2023	Konsultasi Bab <u>V</u>	
10.	12/9 2023	Perbaikan Bab <u>V</u>	
11.	22/9 2023	Acc Bab I, II, III, <u>IV</u> dan <u>V</u>	
12.	27/9 2023	Konsul Jurnal	
13.	1/8 2023	Revisi Jurnal	
14.	2/8 2023	Submit Jurnal	
15.	7/8 2023	Acc untuk sidang TA	

Palembang, Agustus 2023
 Koordinator Program Studi
 Sarjana Terapan Teknik Telekomunikasi,

 Lindawati, S.T., M.TI
 NIP. 197105282006042001

	<p style="text-align: center;">KEMENTERIAN PENDIDIKAN, KEBUDAYAAN, RISET DAN TEKNOLOGI POLITEKNIK NEGERI SRIWIJAYA Jalan Srijaya Negara, Palembang 30139 Telp. 0711-353414 fax. 0711-355918 Website : www.polsri.ac.id E-mail : info@polsri.ac.id</p>	
REKOMENDASI UJIAN TUGAS AKHIR		

Pembimbing Tugas Akhir memberikan rekomendasi kepada,

Nama : Adelia Agatha
NIM : 0619 4035 2351
Jurusan/Program Studi : Teknik Elektro/Sarjana Terapan Teknik Telekomunikasi
Judul Tugas Akhir : *Tracking Hewan Peliharaan Menggunakan Message Queuing Telemetry Transport (MQTT) Berbasis Radio GPS*

Mahasiswa tersebut telah memenuhi persyaratan dan dapat mengikuti Ujian Tugas Akhir (TA) pada Tahun Akademik 2023

Pembimbing I,

Lindawati S.T., M.T.I.
NIP. 197105282006042001

Palembang, 7 Agustus 2023

Pembimbing II,

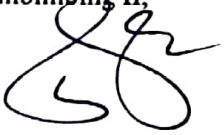
Sarjana, S.T., M.Kom
NIP. 196911061995032001



KEMENTERIAN PENDIDIKAN, KEBUDAYAAN,
RISET DAN TEKNOLOGI

POLITEKNIK NEGERI SRIWIJAYA
Jalan Srijaya Negara, Palembang 30139 Telp. 0711-353414
Laman: <http://polsri.ac.id>. Pos El : info@polsri.ac.id

PELAKSANAAN REVISI TUGAS AKHIR

Mahasiswa berikut,

Nama : Adelia Agatha
NIM : 061940352351
Jurusan/Program Studi : Teknik Elektro/Sarjana Terapan Teknik Telekomunikasi
Judul Tugas Akhir : *Tracking Hewan Peliharaan Menggunakan Message Queuing Telemetry Transport (MQTT) Berbasis Radio GPS*

Telah melaksanakan revisi terhadap Tugas Akhir yang diujikan pada hari Kamis tanggal 10 bulan Agustus tahun 2023 . Pelaksanaan revisi terhadap Tugas Akhir tersebut telah disetujui oleh Dosen Penguji yang memberikan revisi:

No.	Komentar	Nama Dosen Penguji**)	Tanggal	Tanda Tangan
1.	<i>Sdh direvisi</i>	Ir. Abdul Rakhman, M.T NIP. 196006241990031002	<i>17/8-23</i>	
2.	<i>Acc</i>	Hj.Sarjana,ST., M.Kom NIP. 196911061995032001	<i>17/8-23</i>	
3.	<i>ACC</i>	Mohammad Fadhli, S.Pd., M.T NIP. 199004032018031001	<i>15/8-23</i>	

Palembang, 15 Agustus 2023
Ketua Penguji **),

(Ir. Abdul Rakhman, M.T)
NIP 196006241990031002

Catatan:

- *) Dosen penguji yang memberikan revisi saat ujian Tugas Akhir.
**) Dosen penguji yang ditugaskan sebagai Ketua Penguji saat ujian Tugas Akhir.
Lembaran pelaksanaan revisi ini harus dilampirkan dalam Tugas Akhir.





JTIP UNP

Jurnal Teknologi Informasi dan Pendidikan

Department of Electronics, Faculty of

Engineering

Universitas Negeri Padang

Jln. Prof. Dr. Hamka Air Tawar Padang,
25132

E-mail. tip@ppi.unp.ac.id

Website. <http://tip.ppi.unp.ac.id>

LETTER OF ACCEPTANCE

No. 25/UN35/JTIP-LOA/Acc/2023

Dear **Lindawati**,

No. 765

All Authors

Lindawati, Sarjana, Adelia Agatha

Article Title

“Utilization of MQTT and Radio GPS in Pet Monitoring”

Based on the recommendations from the peer review board, we are delighted to inform you that your following manuscript has been **ACCEPTED** for possible publication in **Jurnal Teknologi Informasi dan Pendidikan (JTIP) Vol. 16, No. 2, (2023)**.

Thank you for making the journal a vehicle for your research interests.

August 04, 2023

Best wishes,



Chief Editor

(Jurnal Teknologi Informasi dan Pendidikan)

Mobile Phone. +628 1363 609 995

This journal has been nationally **accredited Sinta 3** based on SK No. 200/M/KPT/2020 (23 Desember 2020).



Utilization of MQTT and Radio GPS in Pet Monitoring (Palatino Linotype, Center, Bold, 14pt)

Lindawati¹, Sarjana², Adelia Agatha^{3*} (10pt)

¹Electrical Engineering, Bachelor of Applied Telecommunication Engineering, Sriwijaya State Polytechnic, Indonesia

²Electrical Engineering, Bachelor of Applied Telecommunication Engineering, Sriwijaya State Polytechnic, Indonesia

³Electrical Engineering Bachelor of Applied Telecommunication Engineering, Sriwijaya State Polytechnic, Indonesia

*Corresponding Author: 061940352351@student.polsri.ac.id

*No. HP/Whatsapp: 089647868646

Article Information

Article history:

No. 001

Rec. August 22, 1993

Rev. Month dd, yyyy

Acc. Month dd, yyyy

Pub. Month dd, yyyy

Page. 22 – 23

Keywords:

- Tracking
- Real-time
- Security
- MQTT

ABSTRACT (10pt)

This research presents an effective and efficient solution for tracking pets using Message Queuing Telemetry Transport (MQTT) based on radio GPS. The study creates a device and application capable of monitoring the whereabouts of pets to prevent their loss by displaying the latitude and longitude of the pet's location. This application provides real-time monitoring and exhibits high accuracy, with minimal differences in latitude and longitude compared to both animal tracking applications and Google Maps. The application's update speed is also impressive, with a delay of only 4.25 seconds. By continuously developing and enhancing this technology, it is expected to provide broader benefits to the pet-loving community.

This is an open access article under the [CC BY-SA](https://creativecommons.org/licenses/by-sa/4.0/) license.



1. INTRODUCTION (11 pt)

In the real of social life, there must be a group of people who have pets, such as dogs, cats, and others. Today cats are one of the most popular pets in the world[1]. These animals have the instinct to live socializing alone without their owners, therefore some animals sometimes like to travel away from their owner's house if the animal is not put in a cage[2]. However, this is very risky because the possibility that animals will disappear from their place of origin is quite large, for example cats roam far enough to the streets, and can be to smaller and narrower places so that they are not visible[3]. Pet supervision and tracking is essential in ensuring the safety, health and well-being of pets. However, traditionally, the pet tracking process has often faced complex and inefficient challenges.

The use of Message Queuing Telemetry Transport (MQTT) technology based on lightweight communication protocols and GPS radio systems promises an innovative approach to improve efficiency and accuracy in tracking pets in real-time[4].

This study aims to present an effective and efficient solution in tracking pets using GPS-based Message Queuing Telemetry Transport (MQTT) technology[5]. The proposed system would overcome obstacles encountered in pet monitoring, such as data loss, communication distance limitations, and delays in location updates. With the application of MQTT and GPS radio technology, it is expected that pets can be monitored in real-time with high accuracy and minimal possibility of error[6].

In implementing MQTT and GPS radio-based pet tracking solutions, there are several issues to consider, such as the power consumption of pet-attached devices, data security and privacy, and the scalability of the system to monitor multiple pets simultaneously. In addition, integration with other technologies in the context of the Internet of Things (IoT) can also be an important consideration to improve system functionality and performance[7].

Previously, several studies have been conducted by other researchers in an attempt to address the issue of pet tracking. Several studies have proposed the application of GPS technology, but face limitations in long-distance communication and high power consumption[8]. Some studies have also tried to use wireless communication technologies such as Bluetooth and Wi-Fi, but there are still challenges in optimizing network availability and data reliability[9]. In some cases, research has also tried to leverage IoT-based technologies to enable real-time monitoring of pets, but aspects of integration and scalability are still a concern. Therefore, this study will build on and expand on previous research by utilizing GPS-based MQTT radio technology to present a more efficient and accurate solution in tracking pets. It will be controllable via an internet-enabled smartphone connected to an app built with MIT App Inventor and Thingspeak[10]. This is expected to make it easier for animals to use this tracking tool.

By outlining the background issues resolved, related issues, and relevant reviews of previous research, this research aims to make a significant contribution to the development of pet tracking technologies that can improve their quality of life and safety.

2. RESEARCH METHOD (11 pt)

This research was carried out in the implementation stage, namely the stage of hardware design, testing software design and research data retrieval. The stages of research can be seen in the research framework of figure 1 below:



Figure 1. Research Framework

2.1 Hardware Design

Hardware design begins with the creation of a circuit diagram scheme. In this study, there is a design scheme for a series of electronic components in the tool to be made.

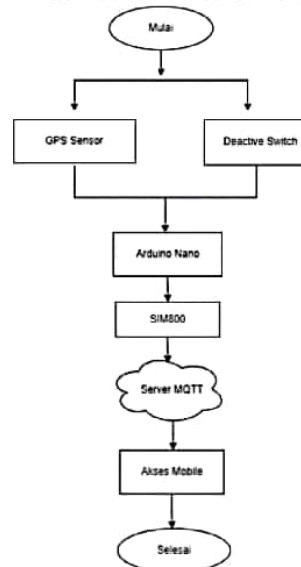

Figure 2. Hardware Design Scheme

2.2 Software Design

After the hardware design stage or device components are assembled and assembled, of course, it cannot be separated from software design, namely using an android application as a pet monitoring application. The initial stage of this research was to design an Android-based animal tracking application using MIT App Inventor. The app will be integrated with a GPS radio module to collect real-time pet location data. After designing the application interface, researchers will integrate the MQTT protocol into the application code using MIT App Inventor's block logic. The use of MQTT will allow applications to transmit animal location data to MQTT servers. The application will be connected with a GPS radio module installed on the pet. This module will take GPS location data and send it to the application. Animal location data received from the GPS radio module will be transmitted from the app to the ThingSpeak channel via the MQTT protocol. ThingSpeak will serve as a data storage and analysis platform during research. Location data stored on ThingSpeak will be analyzed by researchers to track the pet's movements over time. In figure 3 below shows a flowchart which is the logic flow of the MIT App Inventor application.

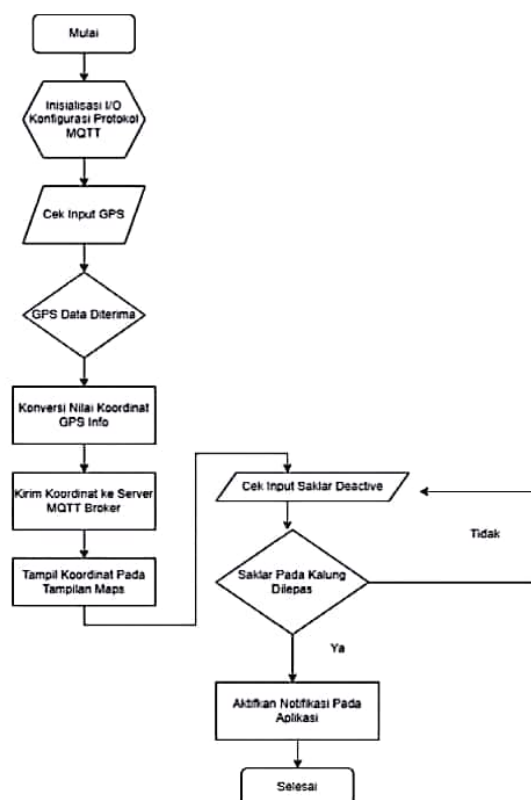

Figure 3. Software Design Flowchart

2.3 Block Circuit Diagram

This research resulted in a small box-shaped animal tracking device that can be attached to a pet's neck for real-time monitoring. It uses the NEO-6M GPS module, Arduino Nano, and SIM 800L to retrieve animal coordinates sent via the MQTT protocol to an MQTT server based on ThingSpeak. This tool uses lithium batteries as a power source. There is a deactive switch to read the GPS condition when the necklace is removed.

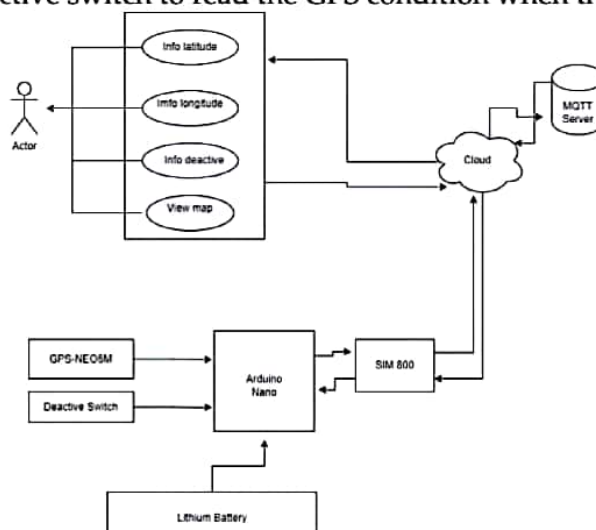

Figure 4. Block Circuit Diagram

In figure 4 is a diagram of a series of tools where when the Neo 6M GPS radio receives a coordinate position signal from the GPS of the peliharaan animal or when the deactive switch reads the GPS condition when the bracelet is removed, the Arduino nano will process GPS reading data and switches that are forwarded to MQTT by sim 800, information that has been received by the MQTT server at the broker in the process of publishing and subscribing to GPS data and the deactive condition of the tool. After the process is complete, the Actor can access cat tracking information in the form of monitoring the reading of coordinates, folders, and the condition of the GPS bracelet's Deactive GPS when released.

2.4 Data Recorder Design Stage with Arduino IDE and ThingSpeak.

In order for the SIM800L to access and send data to ThingSpeak, a *library* called "ThingSpeak" is needed that will help manage communication between the SIM800L and the ThingSpeak cloud platform. In addition, to be able to receive data from the GPS module, the "TinyGPS" library is needed which functions to process data from the GPS module and retrieve coordinate information.

Once the coordinate data has been retrieved from the GPS module using the TinyGPS library, the next step is to convert the data into a string form so that it can be sent to ThingSpeak. The coordinate data taken from the GPS module is usually numeric values, such as latitude and longitude. In the process of sending data to ThingSpeak, the data must be converted into HTTP URL format or parameters containing coordinate information in the form of strings. This format allows data to be transmitted over the HTTP/GET protocol to update data on the ThingSpeak channel.

With the help of the ThingSpeak and TinyGPS libraries, as well as the transformation of data into string form, animal tracker tools can access and send animal location data to ThingSpeak using the SIM800L module and GPS module efficiently and accurately. This process becomes important in the success of real-time animal monitoring and data collection for further analysis.

2.5 Tool Testing Phase

The testing phase is carried out to test the performance of animal *tracking* tools that have been designed with simulations in field areas. This trial aims to ensure that the tool can function properly in retrieving animal location data using the GPS module, sending data via the SIM800L module to the ThingSpeak cloud platform, and being able to read and analyze data received from ThingSpeak. In the trial phase, there are two tests conducted to test the performance of the animal tracker tool that has been designed:

1. Site Accuracy Testing:

This test was conducted by comparing the latitude and longitude values produced by the animal tracker tool with the latitude and longitude values provided by Google Maps. The tool is placed on a specific location, and the location detected by the GPS module will be compared with the actual location displayed on Google Maps. The results of this comparison will show the extent of the accuracy of the tool in taking animal location data.

2. Location Update Speed Testing:

This test aims to measure the speed of the tool in updating animal location data. The tool will be moved from one location to another, and the time it takes for the tool to update its latitude and longitude will be calculated. This test will provide information about how quickly the tool can deliver new location data to the ThingSpeak platform or other servers.

3. RESULTS AND DISCUSSION (11 pt)

In this study, making animal tracking tools and applications with testing

3.1 Animal Tracker Prototype

The prototype of this animal tracking tool is designed in the form of a necklace that can be hung around the pet's neck. The prototype casing is made of ABS plastic material. This tool has dimensions of 4.5 cm long, 2.5 cm wide, and 2 cm high, making it quite compact and suitable for use on farm animals.

This necklace-shaped design was chosen so that the tool can be comfortably attached to the neck of the animal without causing discomfort or disturbance to the animal. In addition, ABS plastic material provides the strength and durability necessary to protect the electronic components inside. With relatively small dimensions, this animal tracker tool can be applied to various types of animals without disturbing their mobility. This prototype is the beginning of further development to create an efficient animal tracking tool that can help in real-time monitoring of animals.



Figure 5. *Prototype animal tracking tool*

3.2 Testing Animal Tracking Tools

Accuracy testing is carried out at several location points, and the results are obtained in the form of latitude and longitude values. In this test, using the Google Maps application as a comparison of animal tracking applications. The test was conducted by comparing location data captured by the Animal Tracking application with location data displayed by the Google Maps application at each test location point. Latitude and longitude data obtained from both applications were then analyzed to assess the extent of

the accuracy of the animal tracker tool in recording and retrieving pet location data.

Using MIT App Inventor as an *Animal Tracking* app creation tool, this test aims to evaluate the performance and accuracy of apps created with the platform. The results of the test will give an idea of the level of accuracy and accuracy of the tool in tracking the location of animals at certain points. Evaluation of test results will help in identifying potential improvements or performance improvements in Animal Tracking applications created using MIT App Inventor, so that applications can provide more accurate and reliable data in real-time animal monitoring.

- First Point

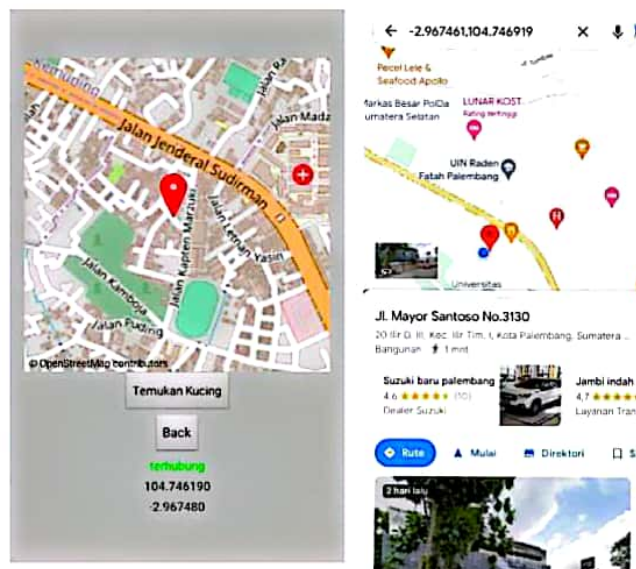

Figure 6. First point location accuracy testing

- Second Point

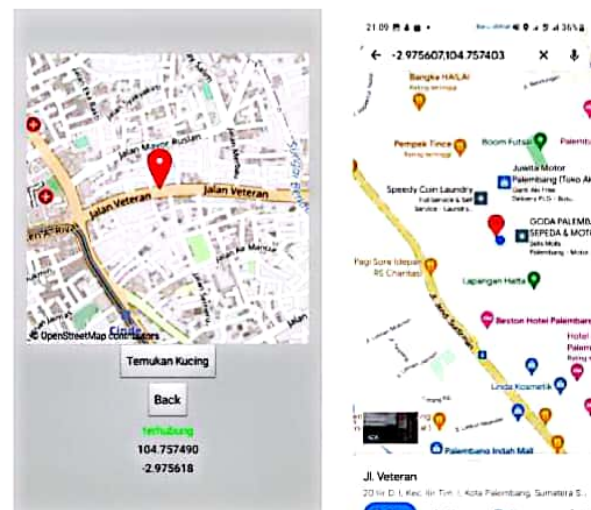

Figure 7. Second point location accuracy testing

- Third Point

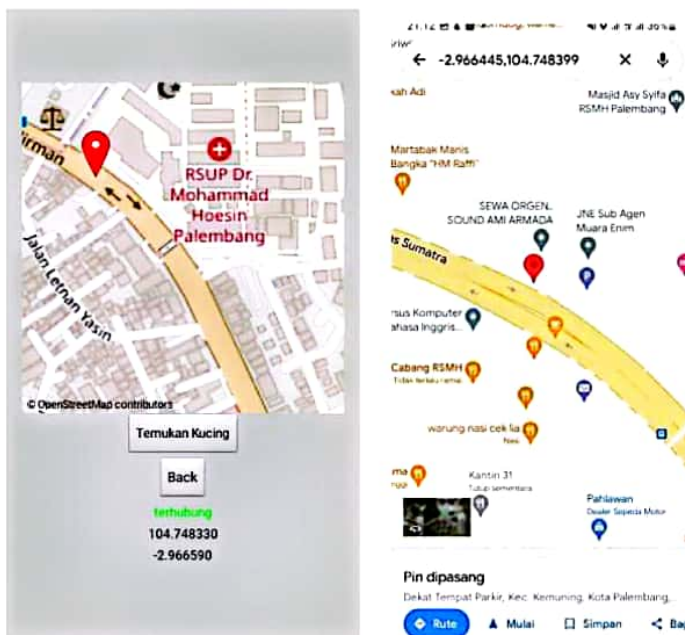

Figure 8. Third-point location accuracy testing

- Fourth Point

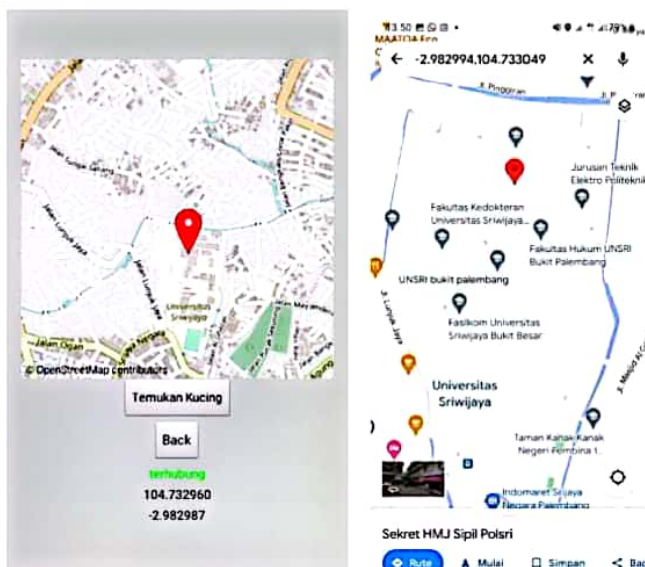

Figure 9. Fourth point location accuracy testing

Table 1. Comparison of Test Location Points

Experiment	App Animal Tracking		App Google Maps	
	Latitude	Longitude	Latitude	Longitude
1	-2.967480	104.746190	-2.967461	104.746919
2	-2.975618	104.757490	-2.975607	104.757403
3	-2.966590	104.748330	-2.966445	104.748399
4	-2.982987	104.732960	-2.982994	104.733049

Based on the data from table 1 above, the latitude and longitude values obtained by the Animal Tracking application and the Google MAPS application are slightly different.

1. Average *latitude* comparison

Average animal tracking app

$$(-2.967480) + (-2.975618) + (-2.966590) + (-2.982987)$$

$$= -11.892.675/4$$

$$= - 2.973.168,75$$

Average Google Maps app

$$(-2.967461) + (-2.975607) + (-2.966445) + (-2.982994)$$

$$= -11.892.507/4$$

$$= -2.973.126,75$$

(Average animal tracking app) – (Average GMAPS app)

$$= (- 2.973.168,75) – (-2.973.126,75)$$

$$= 42$$

2. Average *Longitude* comparison

Average animal tracking app

$$((104.746190) + (104.757490) + (104.748330) + (104.732960))/4$$

$$= 418.984.970/4$$

$$= 104.746.243$$

Average Google Maps app

$$((104.746919) + (104.757403) + (104.748399) + (104.733049))/4$$

$$= 418.985.770/4$$

$$= 104.746.444$$

(Average animal tracking app) – (Average GMAPS app)

$$= (104.746.243) – (104.746.444)$$

$$= -201$$

Based on the calculations above, the animal tracking application made has high accuracy. It can be seen from the difference in latitude and longitude in the animal tracking application and the Google MAPS application.

Table 2. Testing Location *update* speed

Location to-	Time
1	5s
2	4s
3	3s
4	5s

Average *update* speed

$$= (5+4+3+5)/4$$

$$= 4,25 \text{ s}$$

Based on the calculation above, it can be seen that the application delay is quite small on average of 4.25s.

3.3 Menu display in animal tracking application

The tracking process is the main system that functions to see in an interface where the state of the object used as an object to be tracked based on the coordinates of the GPS.

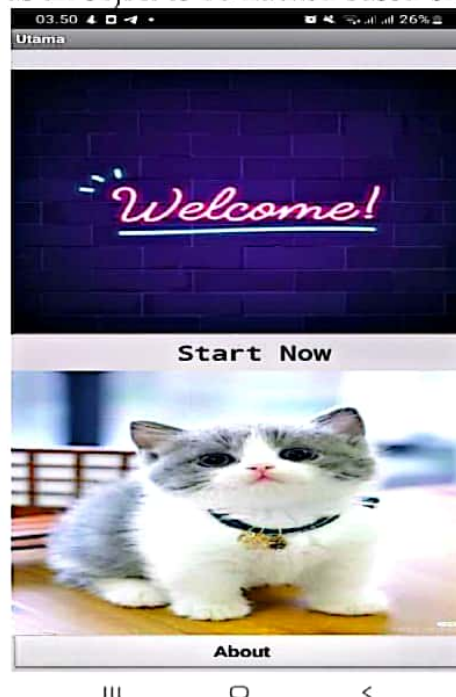

Figure 10. Home



Figure 11. Intro Page



Figure 12. Menu Page

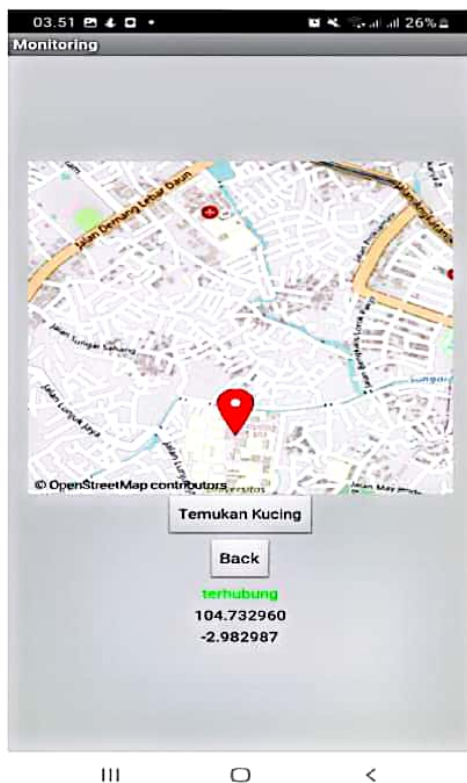

Figure 12. Monitoring Page

In figure 10 to 12 is the display of the animal tracking application which is accelerated using MIT Inventor where this application is equipped with a main page to start using the application which will then display the intro page after clicking "start now". On the intro page, you will be directed to the menu page to start tracking pets with the location of pets displayed in the form of GPS.

3.4 Black Box Testing on Applications

After designing the application, the system is tested using the *black box testing* method to analyze whether all the features in the application can be used. *Black box testing* serves to find out whether the functional needs of the application have been met or errors are still found. The following table of *black box* test results is shown in Table 3 for android-based applications.

Table 3. Black Box Testing Results Android-based Application

No	Testing Parts	Functions in Test	Input	Output	Test Results
1	Home	Start Now button Log in to System	Click Button	Log in to the system and display the intro page.	Accepted
2	Page Into	Next button Back button	Click the Click the	Go to Menu page Back to Main page	Accepted Accepted
3	Menu Page	Next button Back button	Click the Click the	Go to the Monitoring page Back to Intro page	Accepted Accepted
4	Monitoring Page	Find Cat button Back button	Click the Click the	Displays MAPS of cat presence Back to menu page	Accepted Accepted

4. CONCLUSION (11 pt)

After conducting research, it can be concluded that the Animal Tracking tool and application have high accuracy, this application can find out good latitude and longitude with a difference not too high in the comparison between the animal tracking application and the Google MAPS application. The speed of application updates is also good with a delay that is not too high. The application also has good functionality after doing black box testing. Animal Tracking tools and apps show great potential in helping pet owners optimize pet care and safety. By continuing to develop and improve this technology, it is expected to provide wider benefits for the animal enthusiast community.

REFERENCES (11 pt)

- [1] B. J. Christanto and F. Liauw, "Rumah Kebersamaan Antara Hewan Dan Manusia," *J. Sains, Teknol. Urban, Perancangan, Arsit.*, vol. 2, no. 1, p. 21, 2020, doi: 10.24912/stupa.v2i1.6745.
- [2] I. A. Putri, N. Fauziah, and Y. Atifah, "Analisis Perubahan Tingkah Laku Kucing Anggora (*Felis catus*) Betina Selama Masa Kebuntingan," *Pros. Semnas Bio Univ. Negeri Padang*, pp. 857–864, 2021.
- [3] E. D. L. S. L. Lubis, F. I. Harlin, N. A. P. Putri, and Y. Atifah, "Tingkah Laku Reproduksi pada Kucing di Kota Padang Sumatera Barat (Reproductive Behavior of Cats in Padang City , West Sumatera)," *Pros. SEMNAS BIO 2022 UIN Syarif Hidayatullah jakarta*, pp. 644–650, 2022.
- [4] F. P. Uditama, R. Primananda, and M. Data, "Perancangan Aplikasi Pemantauan Pendaki Gunung Menggunakan Wireless Network Dengan Protokol MQTT," *J. Pengemb. Teknol. Inf. dan Ilmu Komput. Univ. Brawijaya e-ISSN 2548-964X*, vol. 2 No 5, no. 5, pp. 2102–2108, 2018, [Online]. Available: <http://j-ptiik.ub.ac.id>
- [5] A. Z. Arfianto *et al.*, "Perangkat Informasi Dini Batas Wilayah Perairan Indonesia Untuk Nelayan Tradisional Berbasis Arduino Dan Modul Gps Neo-6M," *Joutica*, vol. 3, no. 2, pp. 163–167, 2018.
- [6] I. Irawati, F. Y. Roi, T. Y. Agung, and M. Lutfi, "Alat Pelacak Berbasis Long Range Wide Area Network (Lorawan)," *Jeis J. Elektro Dan Inform. Swadharma*, vol. 2, no. 2, pp. 44–48, 2022, doi: 10.56486/jeis.vol2no2.222.
- [7] A. P. Putra, "Sistem Keamanan Sepeda Motor Berbasis Iot (Internet of Things) Dengan Smartphone Menggunakan Nodemcu," *JTT (Jurnal Teknol. Terpadu)*, vol. 9, no. 1, pp. 77–87, 2021, doi: 10.32487/jtt.v9i1.1112.
- [8] G. Y. Saputra, A. D. Afrizal, F. K. R. Mahfud, F. A. Pribadi, and F. J. Pamungkas, "Penerapan Protokol MQTT Pada Teknologi Wan (Studi Kasus Sistem Parkir Univeristas Brawijaya)," *Inform. Mulawarman J. Ilm. Ilmu Komput.*, vol. 12, no. 2, p. 69, 2017, doi: 10.30872/jim.v12i2.653.
- [9] R. Rismayani, M. Patasik, N. S. Layuk, S. Saputra, and A. Muhajir, "Aplikasi Tracking Rekreasi dan Aktivitas Menggunakan Model View ViewModel di Provinsi Sulawesi Selatan," *CSRID (Computer Sci. Res. Its Dev. Journal)*, vol. 14, no. 2, p. 176, 2022, doi: 10.22303/csrid.14.2.2022.176-187.
- [10] I. H. Santoso and A. I. Irawan, "Analisis Perbandingan Kinerja Sensor Jarak HC-SR04 dan GP2Y0A21YK Dengan Menggunakan Thingspeak dan Wireshark," *J. Rekayasa Elektr.*, vol. 18, no. 1, pp. 43–52, 2022, doi: 10.17529/jre.v18i1.23359.

Coddingan Pada Arduino IDE

```
#include <SoftwareSerial.h>
SoftwareSerial gprsSerial(2,3);
#include <String.h>

float lat=123.354456;
float lon=-3.354456;
#include <TinyGPSPlus.h>
#include <SoftwareSerial.h>
static const int RXPin = 5, TXPin = 4;
static const uint32_t GPSBaud = 9600;
// The TinyGPSPlus object
TinyGPSPlus gps;
// The serial connection to the GPS device

int switch_;
void setup()
{
  pinMode(12,INPUT_PULLUP);
  Serial.begin(9600);

delay(500);
  pinMode(12,INPUT_PULLUP);
  Serial.println("gps");

  //Begin serial communication with Arduino and Arduino IDE (Serial
  Monitor)

  gprsSerial.begin(9600);          // the GPRS baud rate
  Serial.begin(9600);             // the GPRS baud rate
  delay(1000);

  gprsSerial.println("AT");
  delay(1000);
```



```

gprsSerial.println("AT+CPIN?");
delay(1000);

gprsSerial.println("AT+CREG?");
delay(1000);

gprsSerial.println("AT+CGATT?");
delay(1000);

gprsSerial.println("AT+CIPSHUT");
delay(1000);

gprsSerial.println("AT+CIPSTATUS");
delay(2000);

gprsSerial.println("AT+CIPMUX=0");
delay(2000);

ShowSerialData();

gprsSerial.println("AT+CSTT=\"web.qtel\""); //start task and
setting the APN,
delay(1000);

ShowSerialData();

gprsSerial.println("AT+CIICR"); //bring up wireless connection
delay(3000);

ShowSerialData();

gprsSerial.println("AT+CIFSR"); //get local IP adress
delay(2000);

ShowSerialData();

}

void loop()
{

```

```

//Serial.println("scan gps!!");
while (Serial.available() > 0)
if (gps.encode(Serial.read()))
{
lat=gps.location.lat();
lon=gps.location.lng();
switch_=digitalRead(12);
  Serial.println("!=" + String(lat,9));
  Serial.println("@=" + String(lon,9));
  Serial.println("#=" + String(switch_,2));
  // if 15 seconds have passed since your last connection,
  // then connect again and send data
  // if (millis() - lastConnectionTime > postingInterval) {

  if(lat==0&&lon==0){

lon=104.7329642501038;
lat=-2.982986853709167;

}

SEND();
}

}

void SEND(){

```

```

    if (gprsSerial.available())
        Serial.write(gprsSerial.read());

    gprsSerial.println("AT+CIPSPRT=0");
    delay(3000);

    ShowSerialData();

gprsSerial.println("AT+CIPSTART=\"TCP\", \"api.thingspeak.com\", \"80\
\"); //start up the connection
    delay(6000);

    ShowSerialData();

    gprsSerial.println("AT+CIPSEND");//begin send data to remote
server
    delay(4000);
    ShowSerialData();
    //api.thingspeak.com/update?api_key=GYP44NQUZ6DF8N&field1="

    String str="GET
https://api.thingspeak.com/update?api_key=GYP44NQUZ6DF8N&field1="
+ String(lon,6)
+"&field2="+String(lat,6)+"&field3="+String(switch_);
    Serial.println(str);
    gprsSerial.println(str);//begin send data to remote server

    delay(4000);
    ShowSerialData();

    gprsSerial.println((char)26);//sending
    delay(5000);//waitting for reply, important! the time is base on
the condition of internet
    gprsSerial.println();

    ShowSerialData();

```

```
gprsSerial.println("AT+CIPSHUT");//close the connection
delay(100);
ShowSerialData();
}

void ShowSerialData()
{
while(gprsSerial.available()!=0)
Serial.write(gprsSerial.read());
delay(5000);
}
```

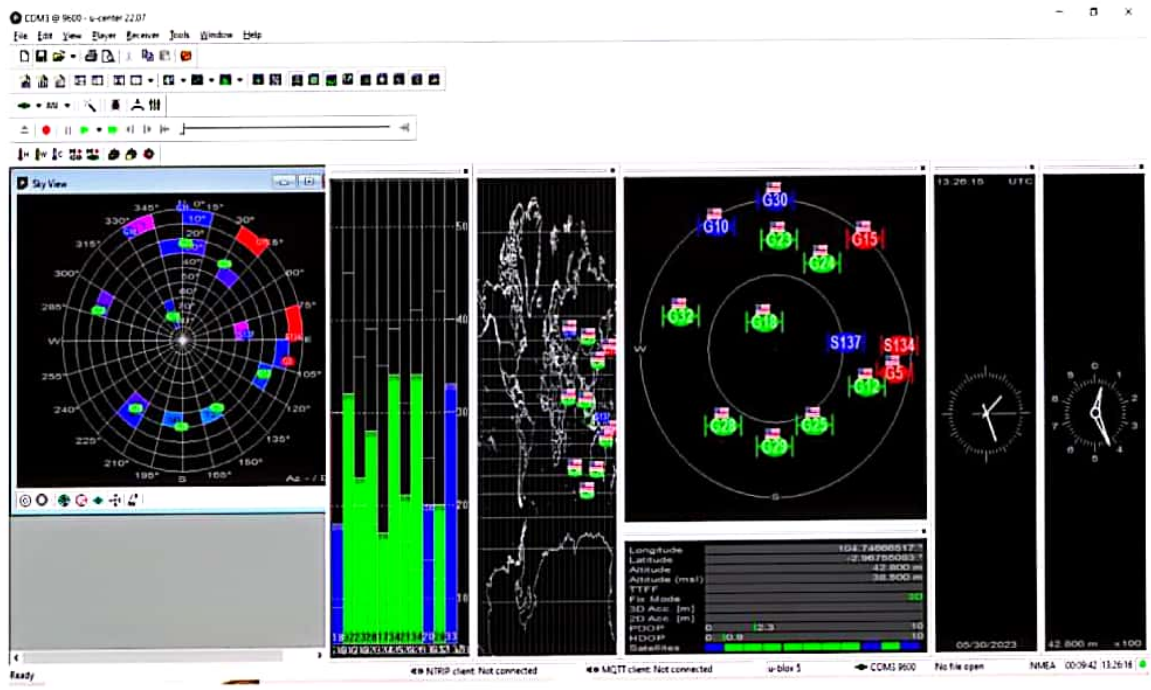
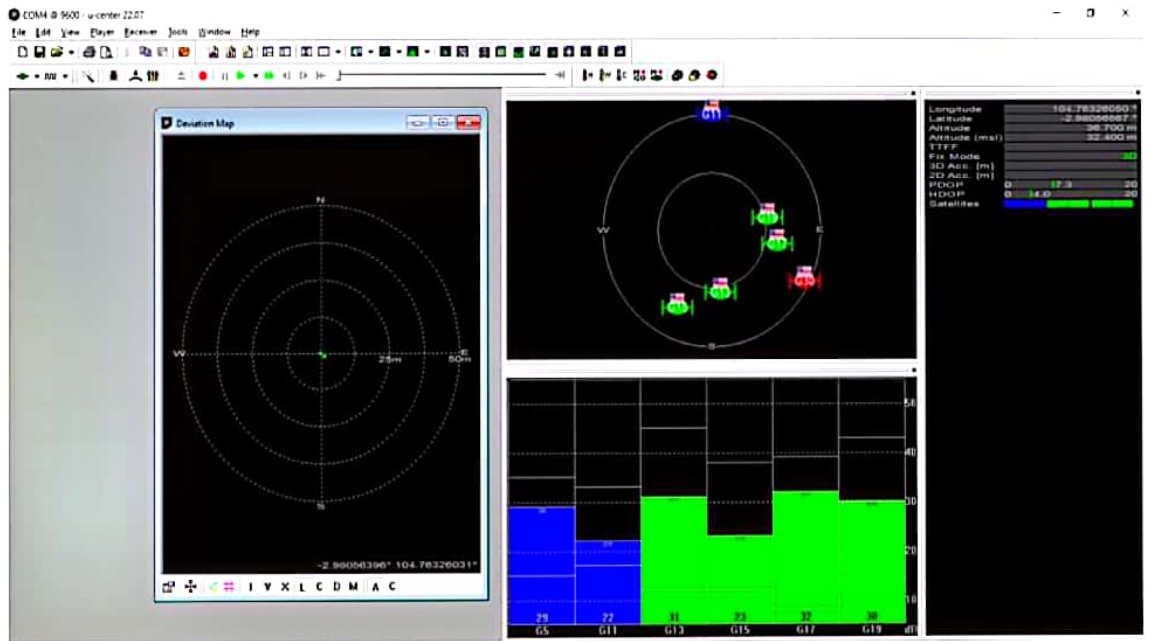

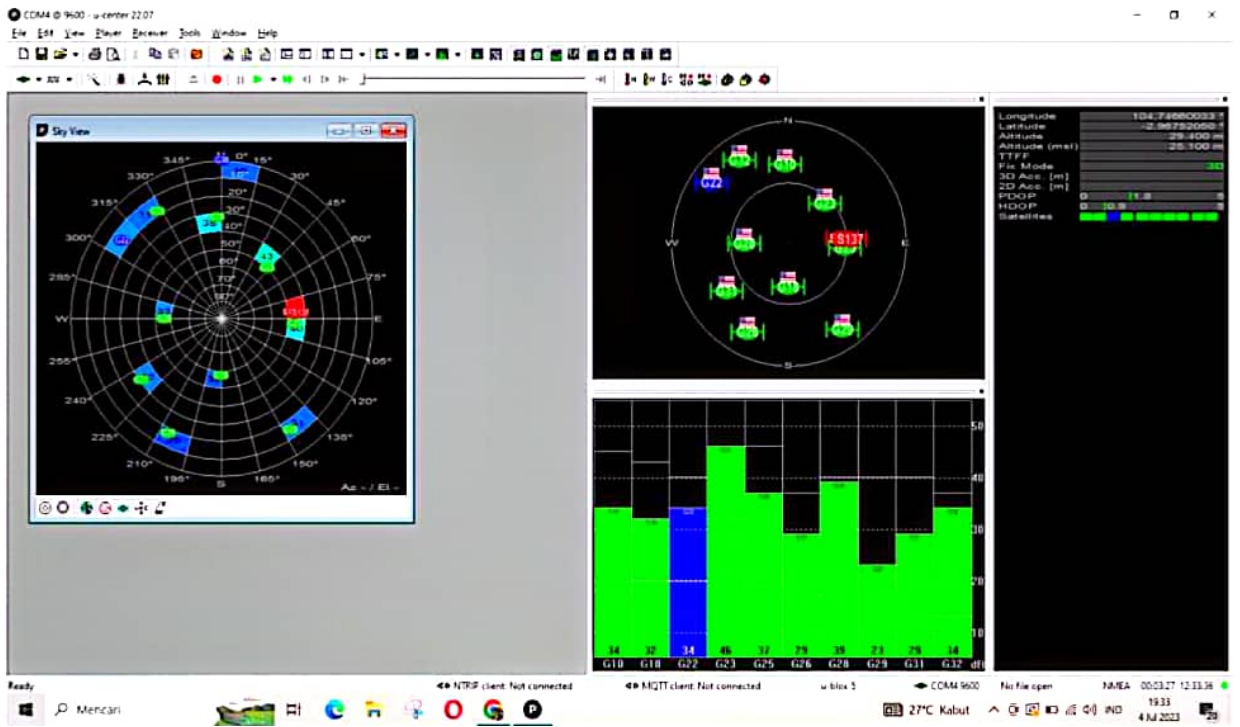
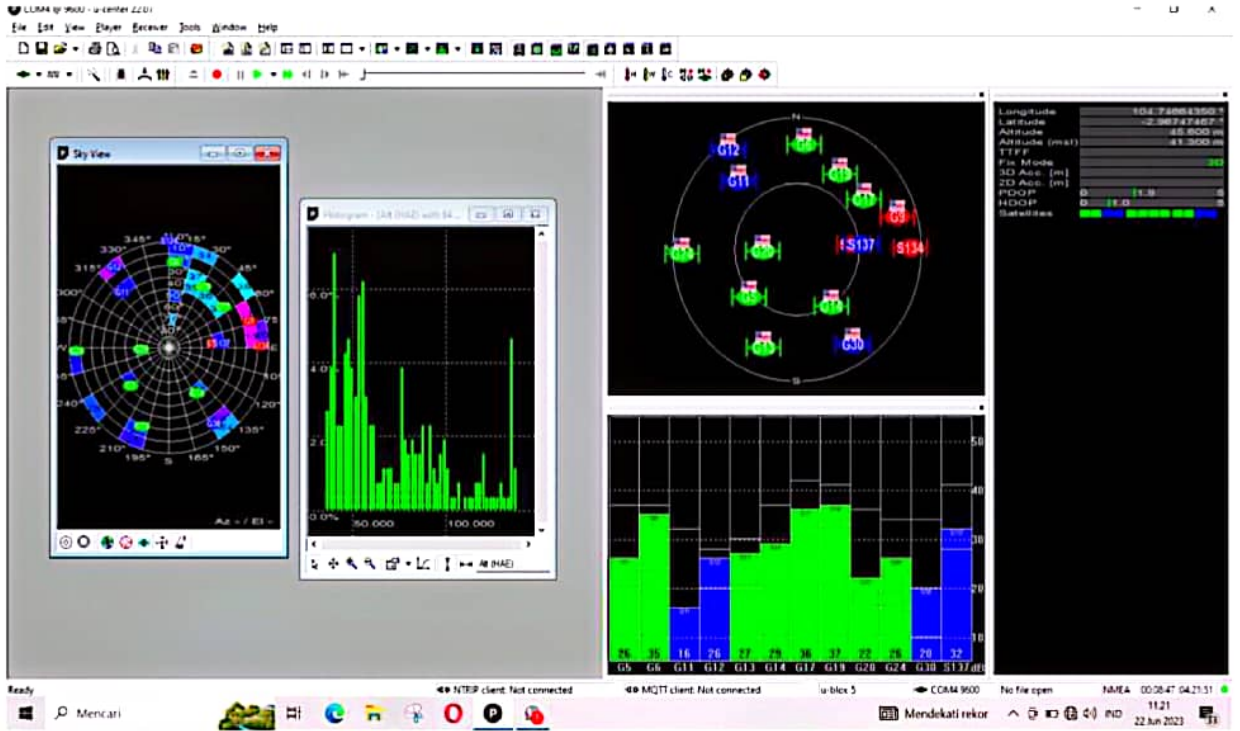
Implementasi Pada Hewan Peliharaan



