

No. 22 Tol. ± 0.1

Bubut
Milling

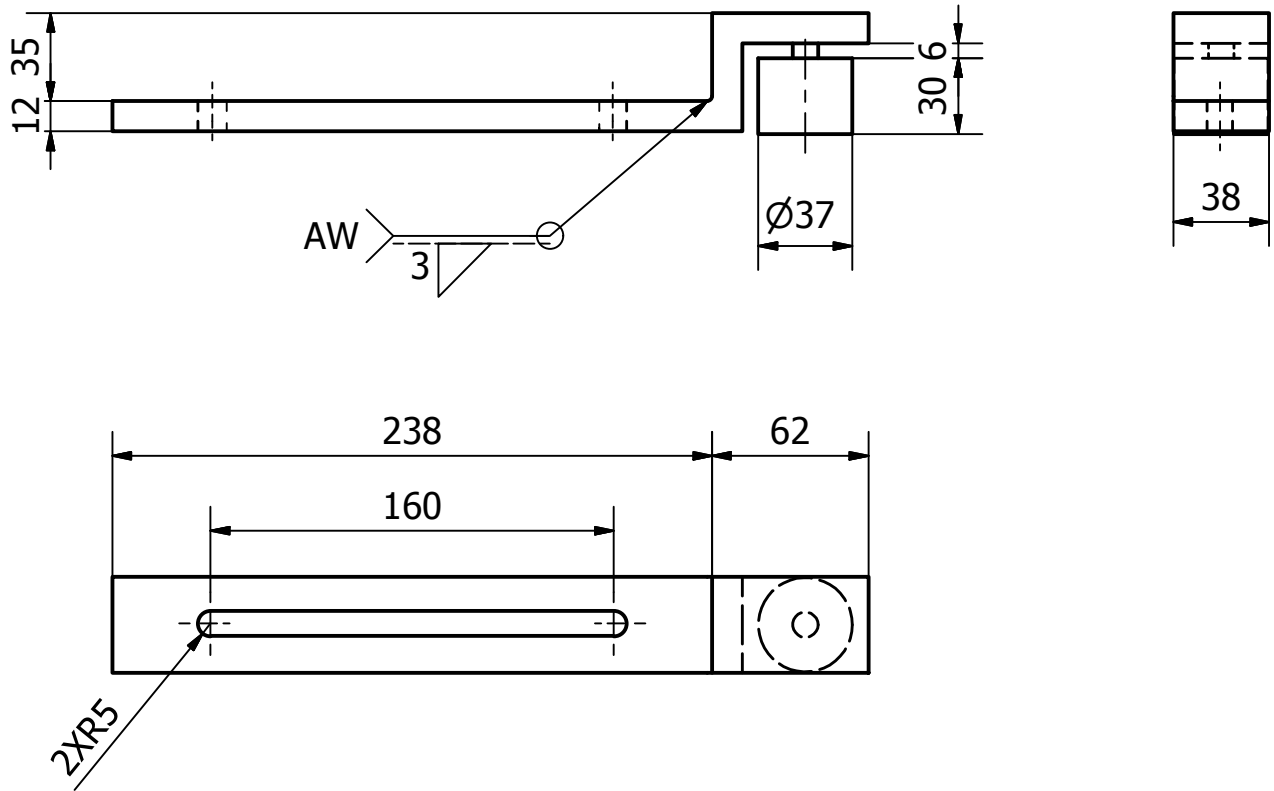

1	Pengarah Begel	22	ST40	300x38x47	Dibuat	
Jumlah	Nama Bagian	No. Bagian	Bahan	Ukuran	Keterangan	
III	II	I	Perubahan :			
				Skala	Digambar	TEAM
				1:2	Diperiksa	
			Politeknik Negeri Sriwijaya		DRA-ME 22/07/16	

Automatic Bending Machine

Politeknik Negeri Sriwijaya

DRA-ME 22/07/16