

LAMPIRAN

NO.1 TOL ± 0.1  BOR

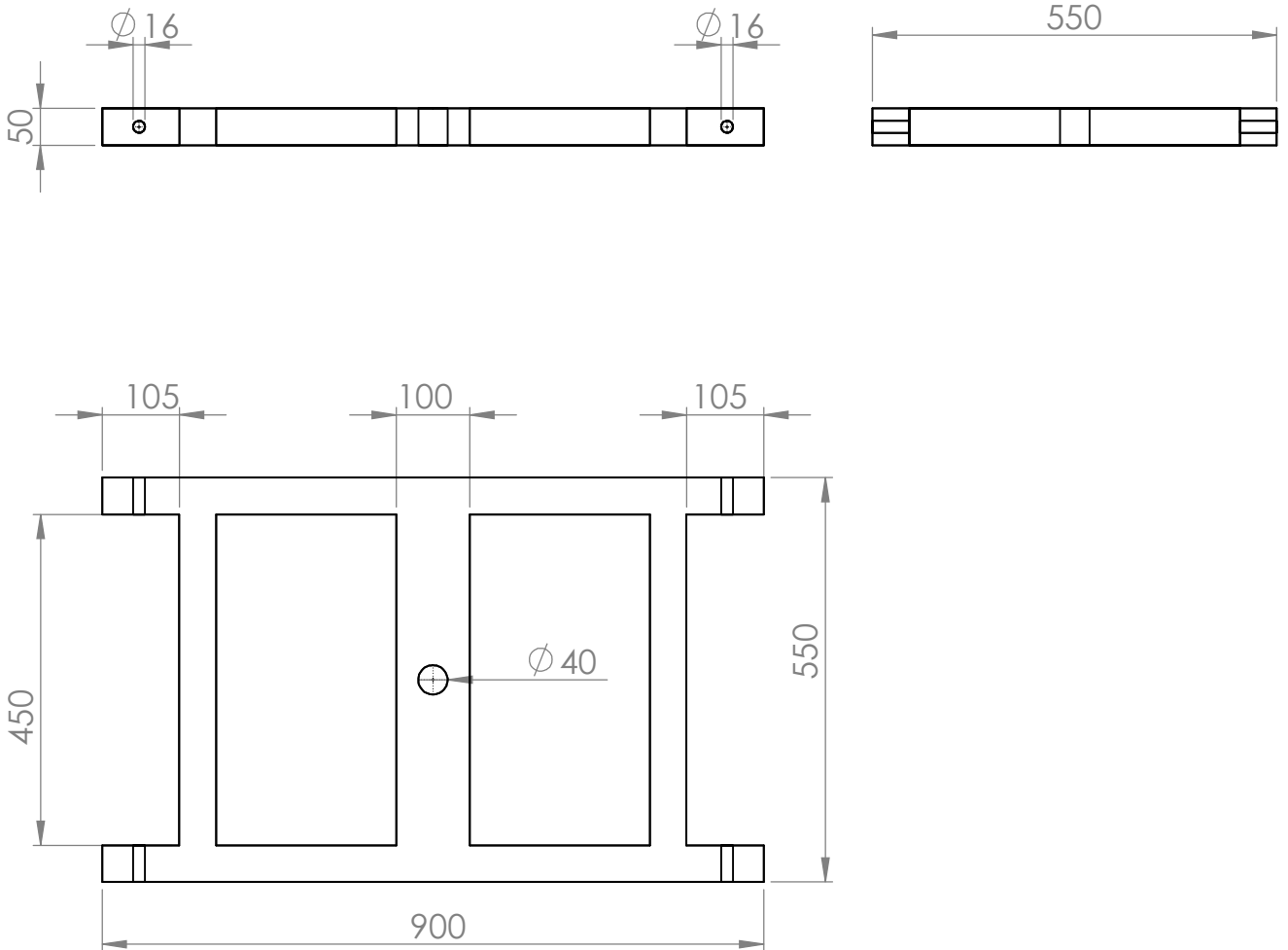
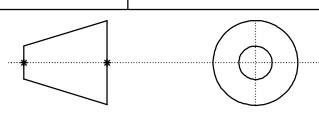
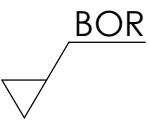

| | | | | | | | | |
|-----------------------------|--------------------|---|---------------------|--------------|---------------|---------------------------------------------------------------------------------------|---------------|------|
| | | 1 | RANGKA BAWAH | 1 | ST-37 | 900 X 550 X 50 | DIBUAT | |
| Jumlah | Nama Bagian | | No. Bagian | Bahan | Ukuran | Keterangan | | |
| III | II | I | Perubahan : | | |  | | |
| | | | RANGKA BAWAH | | | Skala : | Digambar | TEAM |
| | | | | | | 1 : 10 | Diperiksa | |
| POLITEKNIK NEGERI SRIWIJAYA | | | | | | DRA ME NO.1/TA/2017 | | |

NO.3 TOL ± 0.1  BOR

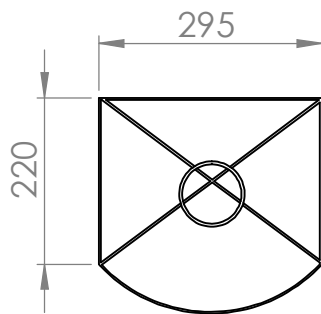
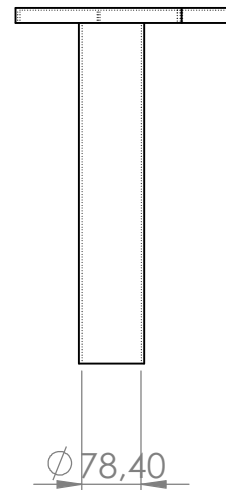
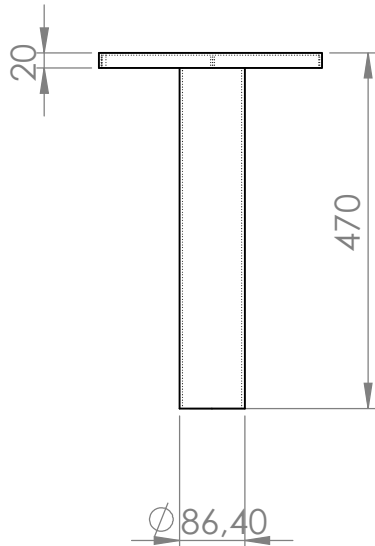

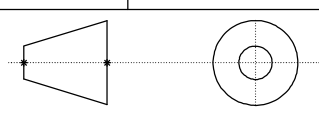
| | | | | | | | | | |
|-----------------------------|----|---|--------------------|------------|-------|---------------------|---------------------------------------------------------------------------------------|----------|------|
| | | 1 | RANGKA ATAS | 3 | ST-37 | 295 X 220 X 470 | DIBUAT | | |
| Jumlah | | | Nama Bagian | No. Bagian | Bahan | Ukuran | Keterangan | | |
| III | II | I | Perubahan : | | | |  | | |
| RANGKA ATAS | | | | | | Skala : | Digambar | 13/07/17 | TEAM |
| | | | | | | 1 : 10 | Diperiksa | | |
| POLITEKNIK NEGERI SRIWIJAYA | | | | | | DRA ME NO.3/TA/2017 | | | |

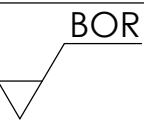
NO.4 TOL ± 0.1  BOR

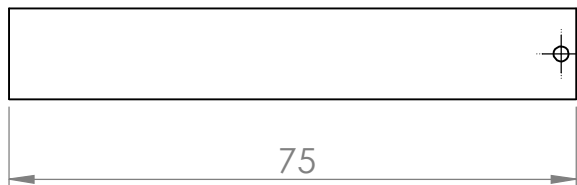
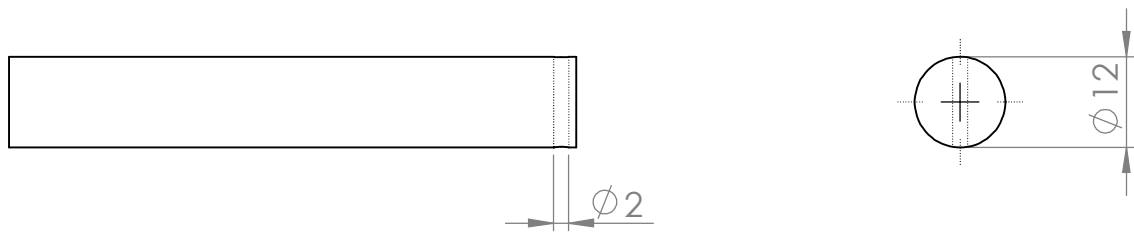

| | | | | | | | |
|--------|-------------|---|-----------------------------|-------|--------|---------------------------------------------------------------------------------------|----------|
| | | 1 | PIN HANDLE TUAS ARM | 4 | ST-37 | $\phi 12 \times 75$ | DIBUAT |
| Jumlah | Nama Bagian | | No. Bagian | Bahan | Ukuran | Keterangan | |
| III | II | I | Perubahan : | | |  | |
| | | | PIN HANDLE TUAS ARM | | | Skala : | TEAM |
| | | | | | | 1 : 1 | Digambar |
| | | | POLITEKNIK NEGERI SRIWIJAYA | | | DRA ME NO.4/TA/2017 | |

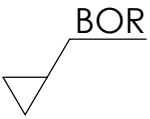
NO.5 TOL ± 0.1 

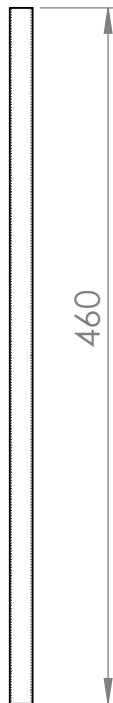
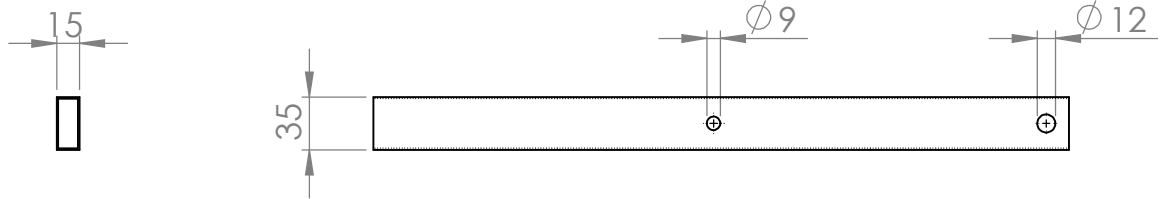

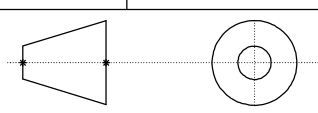
| | | | | | | | | |
|-----------------------------|----|---|-----------------|------------|-------|---------------------|---------------------------------------------------------------------------------------|------|
| | | 1 | HANDLE TUAS ARM | 5 | ST-37 | 460 X 15 X 35 | DIBUAT | |
| Jumlah | | | Nama Bagian | No. Bagian | Bahan | Ukuran | Keterangan | |
| III | II | I | Perubahan : | | | |  | |
| HANDLE TUAS ARM | | | | | | Skala : | Digambar | TEAM |
| | | | | | | 1 - 5 | Diperiksa | |
| POLITEKNIK NEGERI SRIWIJAYA | | | | | | DRA ME NO.5/TA/2017 | | |

NO.6 TOL ± 0.1  BOR

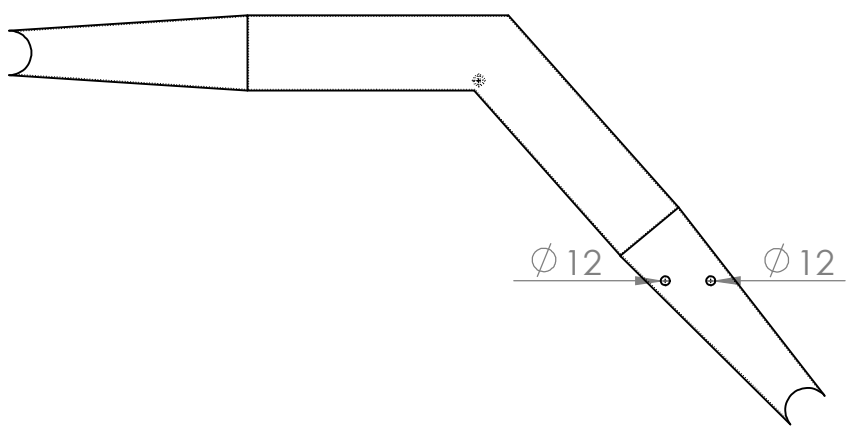
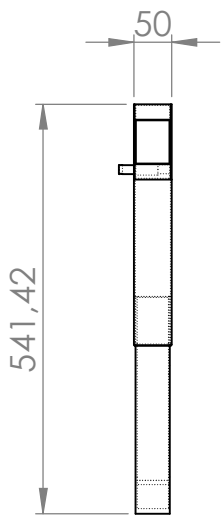

| | | | | | | | | |
|-----------------------------|----|----------|--------------------|-------------------|--------------|---------------------|---------------------------------------------------------------------------------------|------|
| | | 1 | BOOM | 6 | ST-37 | 1078 X 50 X 541 | DIBUAT | |
| Jumlah | | | Nama Bagian | No. Bagian | Bahan | Ukuran | Keterangan | |
| III | II | I | Perubahan : | | | |  | |
| | | | BOOM | | | Skala : | Digambar | TEAM |
| | | | | | | 1 : 10 | Diperiksa | |
| POLITEKNIK NEGERI SRIWIJAYA | | | | | | DRA ME NO.6/TA/2017 | | |

NO.7 TOL ± 0.1  BOR

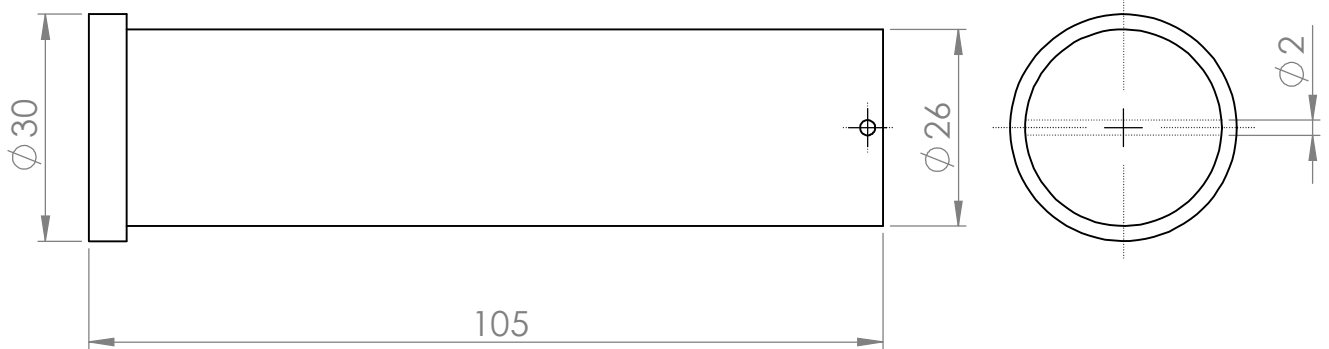

| | | | | | | | | |
|--------|-------------|---|-----------------------------|-------|--------|---------------------------------------------------------------------------------------|----------|------|
| | | 2 | PIN BANTALAN BOOM | 7 | ST-37 | ϕ 30 X 105 | DIBUAT | |
| Jumlah | Nama Bagian | | No. Bagian | Bahan | Ukuran | Keterangan | | |
| III | II | I | Perubahan : | | |  | | |
| | | | PIN BANTALAN BOOM | | | Skala : | Digambar | TEAM |
| | | | | | | | | |
| | | | POLITEKNIK NEGERI SRIWIJAYA | | | DRA ME NO.7/TA/2017 | | |

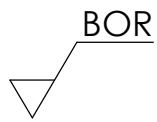
NO.8 TOL ± 0.1  BOR

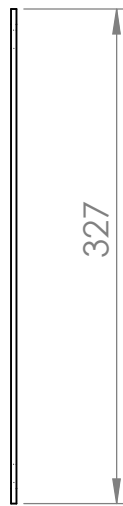
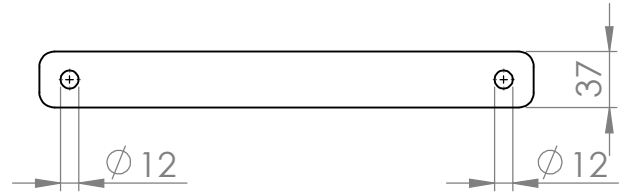
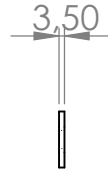

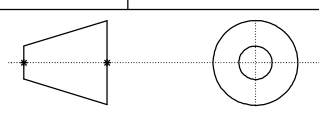
| | | | | | | | | |
|-----------------------------|----|---|---------------|------------|-------|---------------------|---------------------------------------------------------------------------------------|------|
| | | 2 | TUAS BUCKET 2 | 8 | ST-37 | 327 x 3,5 x 37 | DIBUAT | |
| Jumlah | | | Nama Bagian | No. Bagian | Bahan | Ukuran | Keterangan | |
| III | II | I | Perubahan : | | | |  | |
| TUAS BUCKET 2 | | | | | | Skala : | Digambar | TEAM |
| | | | | | | 1 : 5 | Diperiksa | |
| POLITEKNIK NEGERI SRIWIJAYA | | | | | | DRA ME NO.8/TA/2017 | | |

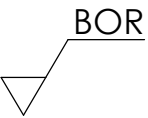
NO.9 TOL ± 0.1  BOR

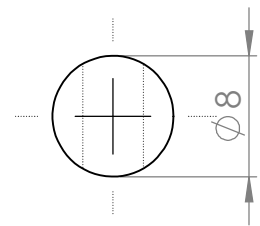
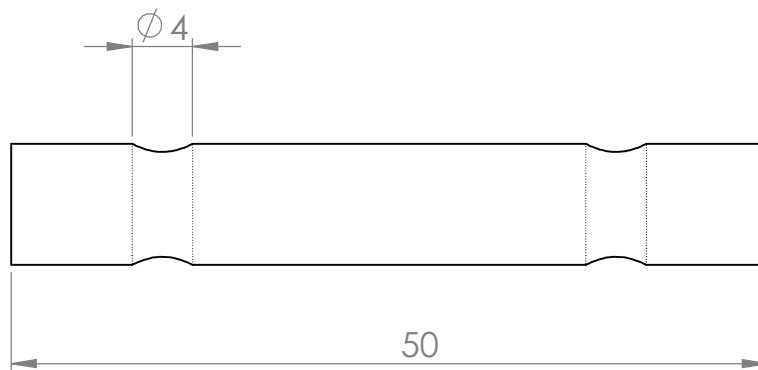

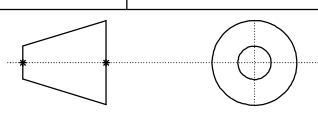
| | | | | | | | | |
|---------------|-----------|--------------------|------------------------------------|-------------------|--------------|---------------------------------------------------------------------------------------|-------------------|------|
| | | 2 | PIN TUAS BOOM KE BUCKET | 9 | ST-37 | ϕ 8 X 50 | DIBUAT | |
| Jumlah | | Nama Bagian | | No. Bagian | Bahan | Ukuran | Keterangan | |
| III | II | I | Perubahan : | | |  | | |
| | | | PIN TUAS BOOM KE BUCKET | | | Skala : | Digambar | TEAM |
| | | | | | | | | |
| | | | POLITEKNIK NEGERI SRIWIJAYA | | | DRA ME NO.9/TA/2017 | | |

NO.10 TOL ± 0.1  BOR

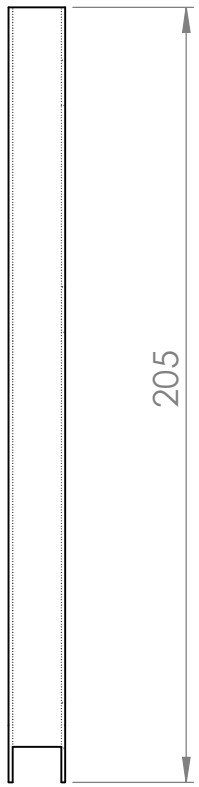
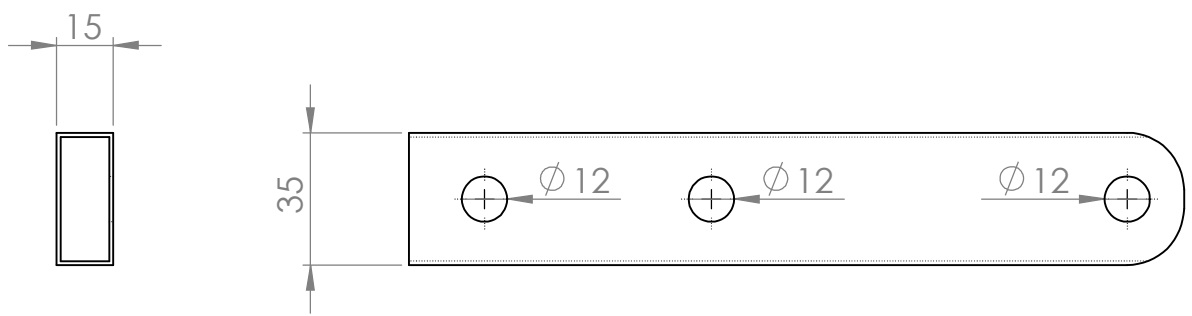

| | | | | | | | | |
|-----------------------------|-------------|---|----------------------|-------|--------|---------------------------------------------------------------------------------------|-----------|------|
| | | 1 | TUAS BUCKET | 10 | ST-37 | 205 X 15 X 35 | DIBUAT | |
| Jumlah | Nama Bagian | | No. Bagian | Bahan | Ukuran | Keterangan | | |
| III | II | I | Perubahan : | | |  | | |
| | | | TUAS BUCKET 1 | | | Skala : | Digambar | TEAM |
| | | | | | | | Diperiksa | |
| POLITEKNIK NEGERI SRIWIJAYA | | | | | | DRA ME NO.10/TA/2017 | | |

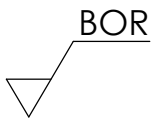
NO.11 TOL ± 1.0  BOR

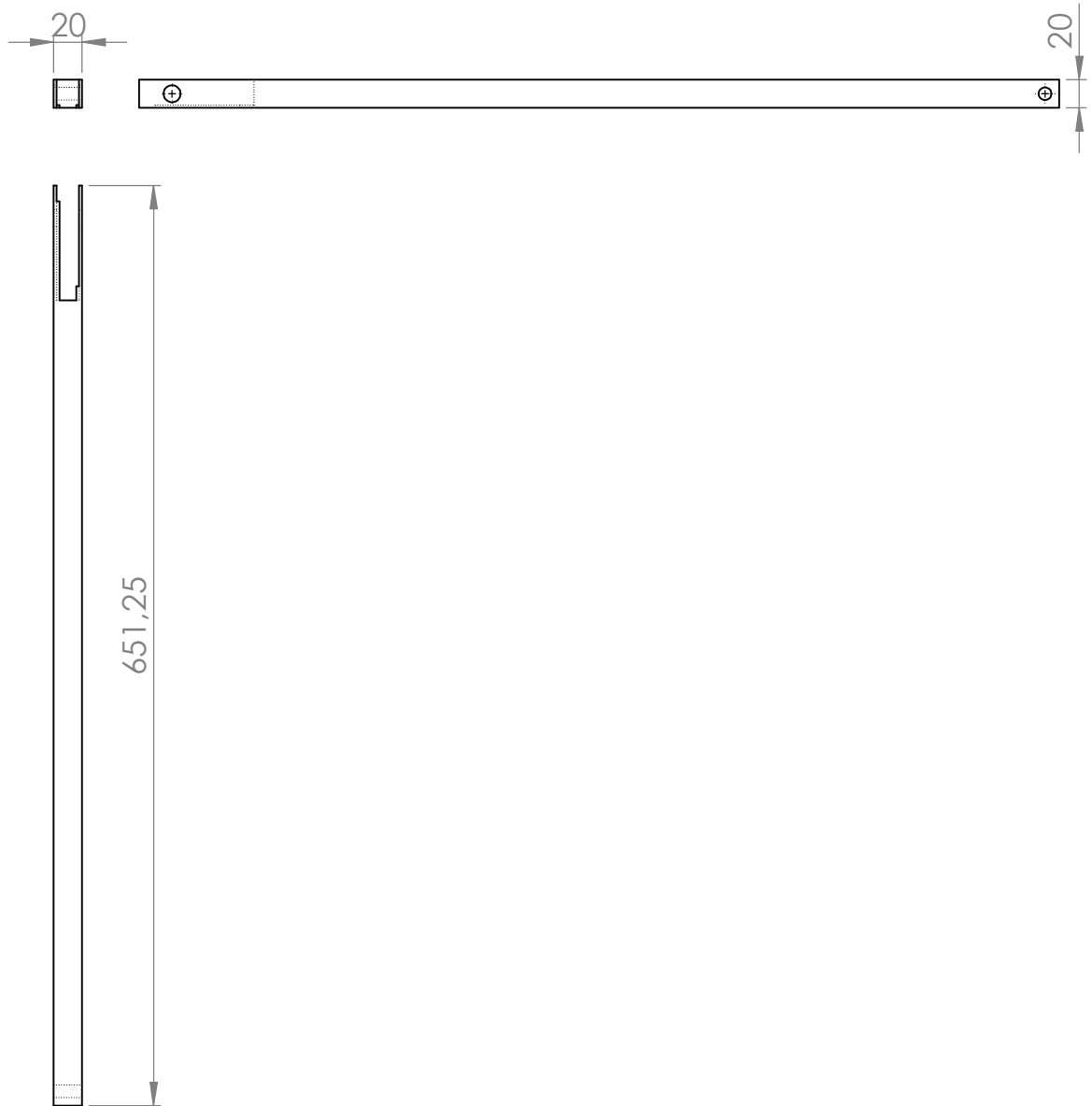

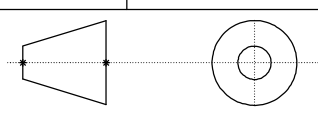
| | | | | | | | | |
|-----------------------------|----|-------------|---------------------|------------|-------|----------------------|---------------------------------------------------------------------------------------|------|
| | | 1 | TUAS BOOM KE BUCKET | 8 | ST-37 | 651 X 20 X 20 | DIBUAT | |
| Jumlah | | Nama Bagian | | No. Bagian | Bahan | Ukuran | Keterangan | |
| III | II | I | Perubahan : | | | |  | |
| TUAS BOOM KE BUCKET | | | | | | Skala : | Digambar | TEAM |
| | | | | | | 1 - 5 | Diperiksa | |
| POLITEKNIK NEGERI SRIWIJAYA | | | | | | DRA ME NO.11/TA/2017 | | |

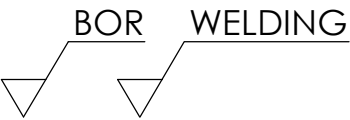
NO.12 TOL ± 0.1 

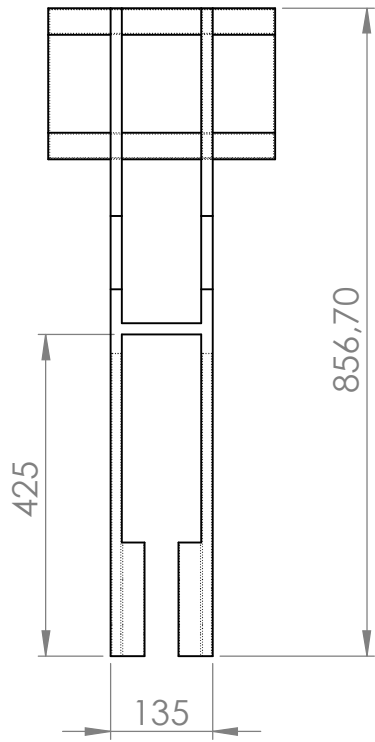
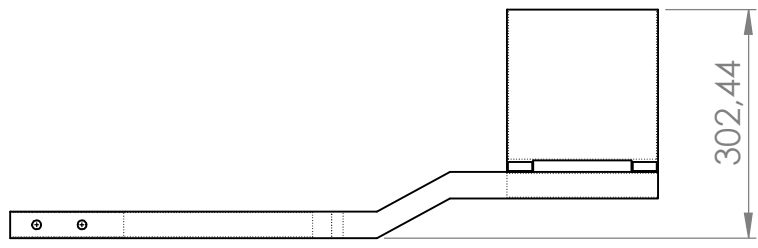
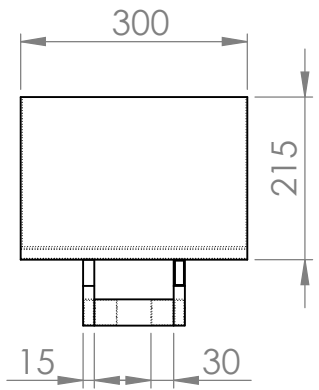

| | | | | | | | | |
|-----------------------------|-------------|---|----------------|-------|--------|---------------------------------------------------------------------------------------|-----------|------|
| | | 1 | COUNTER WEIGHT | 12 | ST-37 | 856 X 300 X 302 | DIBUAT | |
| Jumlah | Nama Bagian | | No. Bagian | Bahan | Ukuran | Keterangan | | |
| III | II | I | Perubahan : | | |  | | |
| COUNTER WEIGHT | | | | | | Skala : | Digambar | TEAM |
| | | | | | | 1 : 10 | Diperiksa | |
| POLITEKNIK NEGERI SRIWIJAYA | | | | | | DRA ME NO.12/TA/2017 | | |

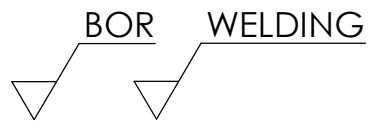
NO.13 TOL ± 0.1 

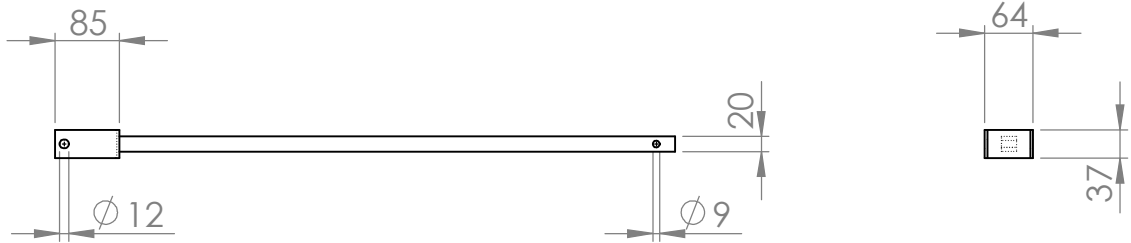

| | | | | | | | |
|-----------------------------|-------------|---|-------------|-------|----------------------|---------------------------------------------------------------------------------------|--------|
| | | 1 | TUAS ARM | 13 | ST-73 | 820 X 64 X 37 | DIBUAT |
| Jumlah | Nama Bagian | | No. Bagian | Bahan | Ukuran | Keterangan | |
| III | II | I | Perubahan : | | |  | |
| TUAS ARM | | | | | Skala : | Digambar | TEAM |
| | | | | | 1 : 10 | Diperiksa | |
| POLITEKNIK NEGERI SRIWIJAYA | | | | | DRA ME NO.13/TA/2017 | | |

NO.14 TOL ± 0.1 BOR WELDING

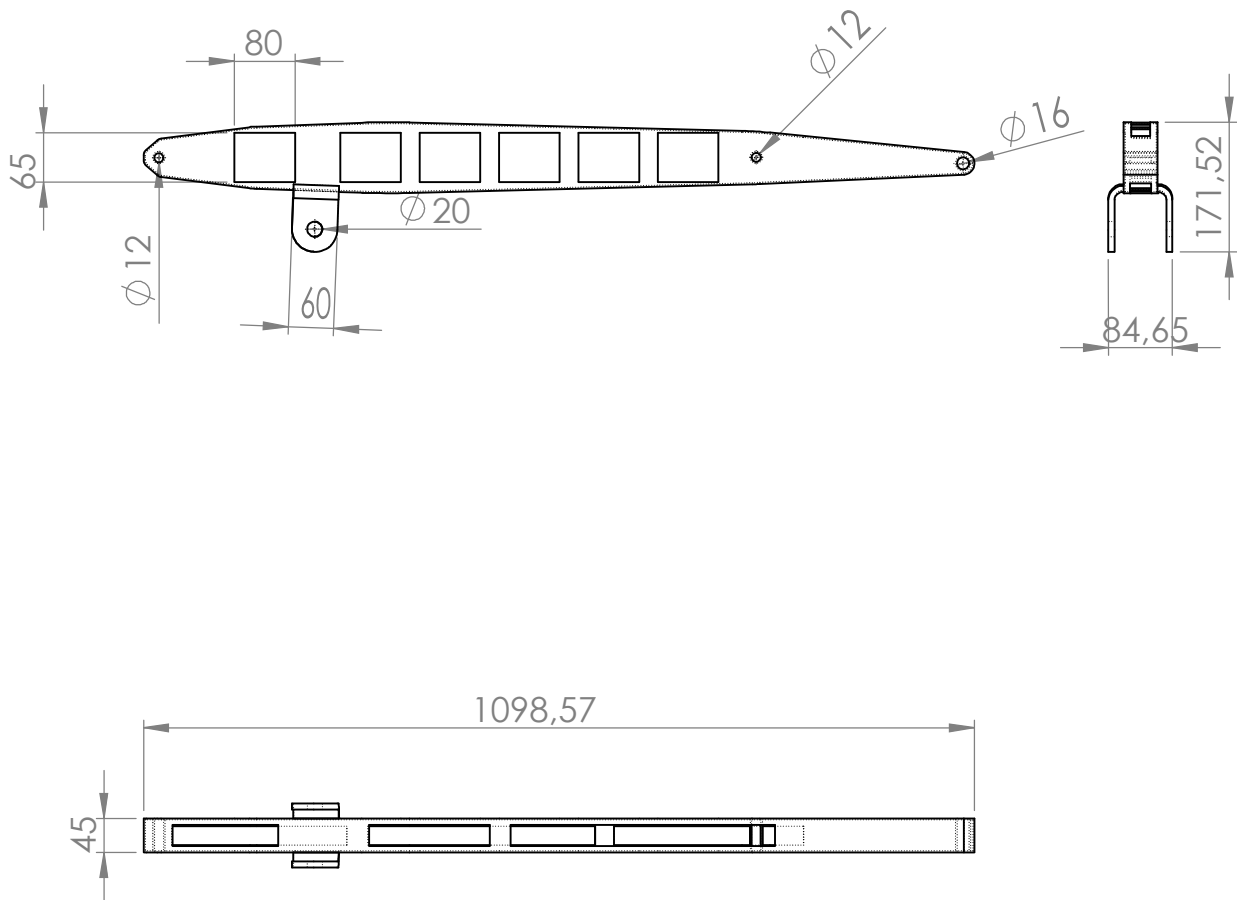

| | | | | | | | |
|-----------------------------|-------------|---|-------------|-------|----------------------|-----------------|--------|
| | | 1 | ARM | 14 | ST-37 | 1098 X 84 X 171 | DIBUAT |
| Jumlah | Nama Bagian | | No. Bagian | Bahan | Ukuran | Keterangan | |
| III | II | I | Perubahan : | | | | |
| ARM | | | | | Skala : | Digambar | TEAM |
| | | | | | | Diperiksa | |
| POLITEKNIK NEGERI SRIWIJAYA | | | | | DRA ME NO.14/TA/2017 | | |

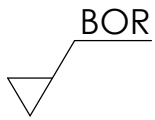
NO.15 TOL ± 0.1 

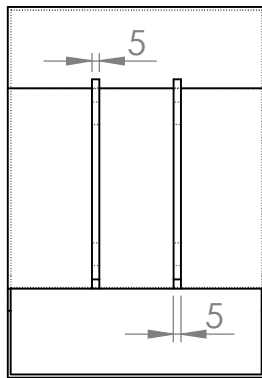
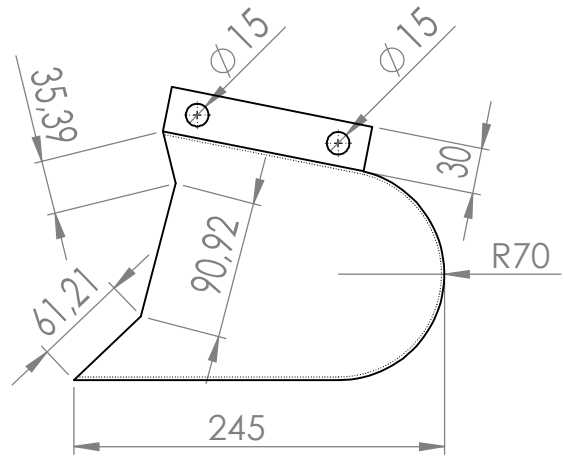
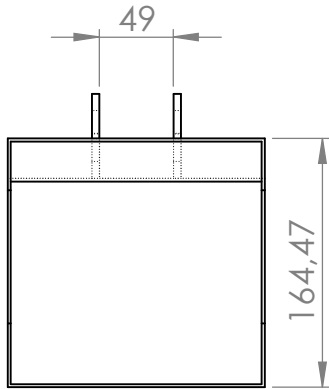

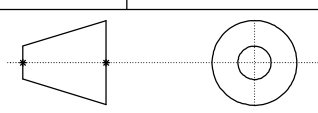
| | | | | | | | | |
|-----------------------------|----|---|---------------|------------|-------|----------------------|---------------------------------------------------------------------------------------|------|
| | | 1 | BUCKET | 15 | ST-37 | 245 X 175 X 164 | DIBUAT | |
| Jumlah | | | Nama Bagian | No. Bagian | Bahan | Ukuran | Keterangan | |
| III | II | I | Perubahan : | | | |  | |
| BUCKET | | | | | | Skala : | Digambar | TEAM |
| | | | | | | 1 : 5 | Diperiksa | |
| POLITEKNIK NEGERI SRIWIJAYA | | | | | | DRA ME NO.15/TA/2017 | | |

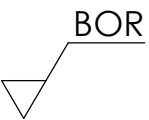
NO.16 TOL ± 0.1 

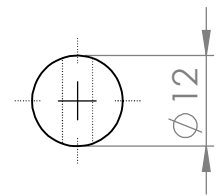
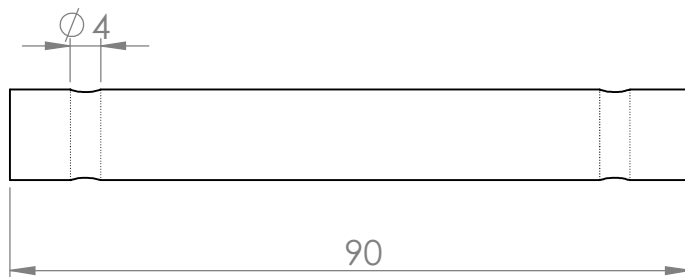

| | | | | | | | | |
|-----------------------------|----|-------------|-------------|------------|-------|----------------------|---------------------------------------------------------------------------------------|------|
| | | 2 | PIN ARM | 16 | ST-37 | ϕ 12 X 90 | DIBUAT | |
| Jumlah | | Nama Bagian | | No. Bagian | Bahan | Ukuran | Keterangan | |
| III | II | I | Perubahan : | | | |  | |
| PIN ARM | | | | | | Skala : | Digambar | TEAM |
| | | | | | | 1 : 1 | Diperiksa | |
| POLITEKNIK NEGERI SRIWIJAYA | | | | | | DRA ME NO.16/TA/2017 | | |

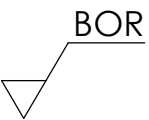
NO.16 TOL ± 0.1 

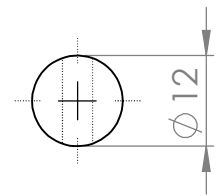
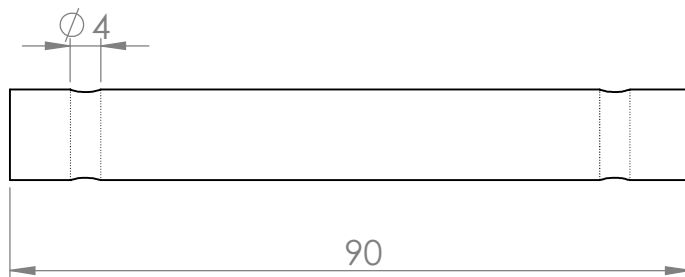

| | | | | | | | | |
|-----------------------------|----|---|-------------|------------|-------|----------------------|---------------------------------------------------------------------------------------|------|
| | | 2 | PIN ARM | 16 | ST-37 | ϕ 12 X 90 | DIBUAT | |
| Jumlah | | | Nama Bagian | No. Bagian | Bahan | Ukuran | Keterangan | |
| III | II | I | Perubahan : | | | |  | |
| PIN ARM | | | | | | Skala : | Digambar | TEAM |
| | | | | | | 1 : 1 | Diperiksa | |
| POLITEKNIK NEGERI SRIWIJAYA | | | | | | DRA ME NO.16/TA/2017 | | |

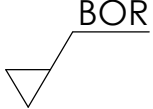
NO.17 TOL ± 0.1  BOR

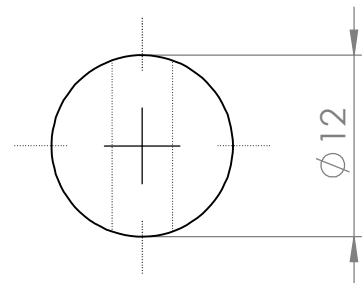
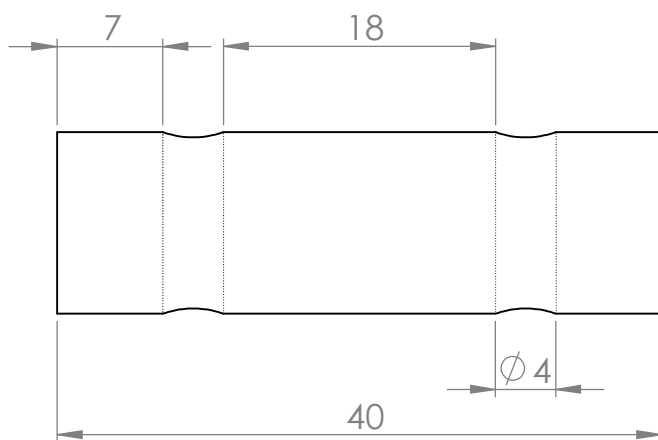

| | | | | | | | | |
|-----------------------------|-----------|--------------------|------------------------|-------------------|--------------|----------------------|---------------------------------------------------------------------------------------|------|
| | | 2 | PIN TUAS BUCKET | 17 | ST-37 | ϕ 12 X 40 | DIBUAT | |
| Jumlah | | Nama Bagian | | No. Bagian | Bahan | Ukuran | Keterangan | |
| III | II | I | Perubahan : | | | |  | |
| | | | PIN TUAS BUCKET | | | Skala : | Digambar | TEAM |
| | | | | | | | | |
| POLITEKNIK NEGERI SRIWIJAYA | | | | | | DRA ME NO.17/TA/2017 | | |



LEMBAR Bimbingan LAPORAN AKHIR

Lampiran 1

Nama : **RICKY IRWAN**
 NIM : **021 3020 1048**
 Jurusan/Program Studi : **TEKNIK MESIN / ALAT BERTENAGA**
 Judul Laporan Akhir : **RANCANG BANGUN SIMULASI EXCAVATOR MINIMAL**

Pembimbing I : **W. H. SAILON, M.T**
 Pembimbing II :

| No. | Tanggal | Isi dan Bimbingan | Tanda Tangan Pembimbing | |
|-----|------------|--------------------------------------------------------------|-------------------------|----|
| | | | I | II |
| 1 | 02-03-2019 | PENGACUAN JUDUL | | |
| 2 | 06-03-2019 | PENGACUAN PROPOSAL (REVISI) | | |
| 3 | 08-03-2019 | PENGACUAN PROPOSAL (ACC) | | |
| 4 | 14-03-2019 | BAB I (REVISI) 1. Latar Belakang | | |
| 5 | 03-04-2019 | BAB I (ACC) BAB I Konsultasi Rumus | | |
| 6 | 05-04-2019 | BAB I (REVISI) 1. Perhitungan Bab 2. Rumus Perhitungan | | |
| 7 | 08-04-2019 | BAB I (ACC) BAB II Konsultasi | | |
| 8 | 10-04-2019 | BAB II (REVISI) 1. Penambahan Gambar 2. Perhitungan | | |
| 9 | 05-05-2019 | BAB III (ACC) | | |

| No. | Tanggal | Daftar Simbolis | Tanda Tangan Pembimbing | |
|-----|------------|-------------------------------------------------------------|-------------------------|----|
| | | | I | II |
| 10 | 24-05-2019 | BAB IV (REVISI) 1. Tabel Pengujian 2. Tabel Perawatan | | |
| 11 | 10-06-2019 | BAB IV (ACC) | | |
| 12 | | <i>Concluded by (Signature)</i> | | |
| 13 | | | | |
| 14 | | | | |
| 15 | | | | |
| 16 | | | | |

Polembang
Ketua Jurusan/KPS

Ir. Saiful Effendi, M.T.
NIP. 196309121989011005

Catatan:

Siswa Jurusan/Kelas Program Studi Teknik Informatika untuk pelaksanaan bimbingan sesuai yang tertera dalam
Pencapaian Laporan Akhir sebagai monev/dorongan untuk bimbingan di
Lampiran penunjang LA di Tesis dan/atau dalam Laporan Akhir



KEMENTERIAN RISET, TEKNOLOGI, DAN PENDIDIKAN TINGGI
POLITEKNIK NEGERI SRINJAYA
Jalan Sri Jaya Negara, Palembang 30138
Telp. 0711-353414 Fax. 0711-365018
Website : www.psnrwiya.ac.id E-mail : info@psnr.ac.id



REKOMENDASI UJIAN LAPORAN AKHIR (LA)

Pembimbing Laporan Akhir memberikan rekomendasi kepada:

Nama Mahasiswa : **RUCI RAHAN**

NPM : **0611-3020-1048**

Jurusan / Program Studi : **TEKNIK MESIN / MEKATRONIKA**

Judul Laporan Akhir : **RANCANG BANGUN SIMULASI
EXCAVATOR MANUAL**

Mahasiswa tersebut telah memenuhi persyaratan dan dapat mengikuti Ujian Laporan Akhir (LA) pada tahun akademik 2017.

Palembang, Juli 2017

Ditetapkan oleh

Pembimbing I

Ir. H. Saiful, M.T.
NIP. 196005041993031001

Pembimbing II

Syamsul Rizal, S.T., M.T.
NIP. 197608212003121001



KEMENTERIAN RISET, TEKNOLOGI, DAN PENDIDIKAN TINGGI
POLITEKNIK NEGERI SRIWIJAYA

Jalan Raya Negeri, Palembang 30132

Telp: 0711-353414 Fax: 0711-325918

Website: www.pnsriwijaya.ac.id E-mail: rfo@pnsri.ac.id



PELAKSANAAN REVISI LAPORAN AKHIR

Merasakan berikut:

Nama

RICKI RAJANI

NPM

0611 - 3020 - 4048

Linier/Program Studi

TEKNIK MESIN / ALAT BEBAT

Judul Laporan Akhir

RANCANG BANGUN SIMULASI EXCAVATOR MANUAL

Telah melaksanakan revisi terhadap Laporan Akhir yang diajukan pada hari _____ tanggal _____ bulan _____ tahun _____. Pelaksanaan revisi terhadap Laporan Akhir tersebut telah disetujui oleh Dosen Penguji yang menandatangani revisi:

| No. | Komentar | Nama Dosen Penguji ¹⁾ | Tanggal | Tanda Tangan |
|-----|------------------|----------------------------------------|----------|--------------|
| | tdk ada revisi | IR. H. SARDON, M.T. | 3/8/17 | |
| | Tidak ada revisi | MUCH. YUSRI, ST., M.T. | 3/8-2017 | |
| | Sudah direvisi | ELLA SUNDARI, ST., MT. | 3/8/17 | |
| | Final, selesai | IR. SAFEL, M.T. | 23/8/17 | |
| | ARC | DEA SATHIA H. B. GMA. DPL. PPG, EPD | 27/8/17 | |

Palembang 3/8-2017

Ketua Penguji¹⁾

NP

Catatan:

- 1) Dosen penguji yang menandatangani revisi saat akan laporan akhir
- 2) Dosen penguji yang ditugaskan sebagai Ketua Penguji saat akan LA
- 3) Revisi pelaksanaan revisi ini harus ditandatangani dalam Laporan akhir