

Innovative MPEG-2 Audio/Video CODEC

Perfect for a Variety of Consumer Electronics Applications

CS92288 Features

- Single-chip, real time MPEG-2 audio/video CODEC with system mux/demux and OSD
- Supports real-time MPEG-1, MPEG-2 MP@ML, SP@ML and MP@LL encoding and decoding
- Support for constant and one-pass variable bit rate
 - IPB-pictures, CBR or VBR to 15 Mbps
 - I-pictures only to 30 Mbps
- Supports Transport, Program, and Elementary streams
- Support for real time encoding and decoding of two-channel digital audio in either Dolby® Digital or MPEG audio (Layer I, II, and III - MP3)
- Programmable system mux/demux supports VCD, SVCD, and DVD encoding and decoding
- 8-bit OSD support (2-bit text, 2-bit to 8-bit graphics)
- Supports multiple resolutions and scan rates
- Low external memory, e.g., NTSC:
 - 8 Mbytes for full D1 (720) NTSC/PAL pictures
- Intel/Motorola 16-bit host interface
- Generic 8-bit glueless interface to multiple devices such as the Philips 7146 PCI Bridge, Philips TriMedia, and USB controllers
- Integrated programmable video pre- & post-processors
- Integrated I²S interface
- 1.00 W at 108 MHz average power consumption
- Available in a 272 BGA package

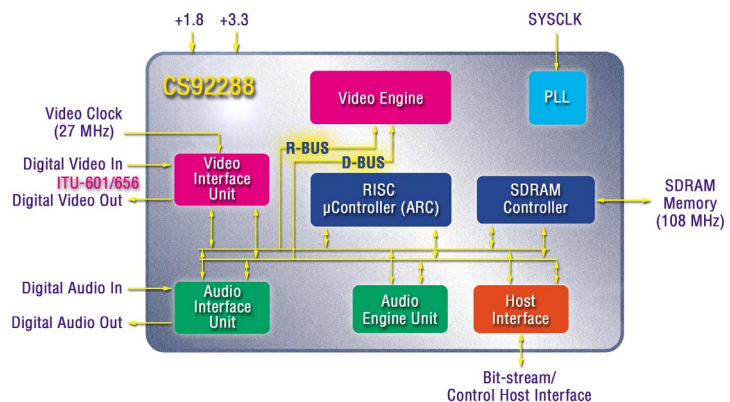

The CS92288 is a real-time MPEG-2 audio/video encoder/decoder (CODEC) with an integrated system multiplexor/demultiplexor and on-screen display (OSD) feature. It offers both audio and video real-time encoding and decoding in a single, highly integrated device. The CS92288 also supports the MPEG-1 and MPEG-2 digital-video standards as well as Dolby Digital and MPEG digital-audio standards. This innovative CODEC enables high-quality video recording in real time over a wide range of bit rates for a variety of consumer applications.

In encode mode, the CS92288 produces MPEG-compliant audio/video elementary, program and transport bit streams for broadcast and set-top boxes. In decode mode, the CS92288 accepts MPEG transport, program and audio/video elementary bit streams. The OSD feature supports both text and 2-bit, 4-bit, and 8-bit graphics enabling user menus, broadcast information, or status updates.

The CS92288 enables high-quality video and audio playback across the widest range of bit rates, offering cost-saving advantages to OEMs. Using a lower bit rate setting provides greater content storage capacity for end-users, which allowing OEMs to cut costs on disk drives by using smaller drives that still provide high visual quality. Several reference designs are available for fast development of consumer electronic products such as DVD recorders, DVD players, and video hard-disk recorders.

Features

Video

- NTSC: (720-D1, 704-D1, 640-VGA, 544, 480-2/3D1, 352-1/2D1) x 480, or 352 x 240 (CIF), or 176 x 112 (QCIF) at 30 or 29.97 Hz
- PAL: (720-D1, 704-D1, 640-VGA, 544, 480-2/3D1, 352-1/2D1) x 576, or 352 x 288 (CIS/SIF), or 176 x 144 (QCIF) at 25 Hz
- Film: (720-D1, 704-D1, 640-VGA, 544, 480-2/3D1, 352-1/2D1) x 480, or 352 x 240 (CIF), or 176 x 144 (QCIF) at 24 Hz
- ITU-R 656 or ITU-R 601
- Digital loopback
- Proprietary high performance motion estimation
 - Half-pel accuracy
 - Programmable search range
 - H search range - 63.5, 31.5, 15.5, 7.5 pel/frame
 - V search range - 31.5, 15.5, 7.5 pel/frame
 - Field, 16 x 8, and frame-mode prediction
- OSD Options
 - Logo On/Off
 - Command menu On/Off
 - Status menu On/Off
 - OSD special effects
- Pre- and post-processing
 - Horizontal and vertical cropping
 - Horizontal and vertical scaling
 - NTSC to PAL format conversion
 - Temporal and spatial filtering
 - Telecine and inverse-telecine

- Programmable encoding parameters
 - IBBBP, IBBP, IBP, IP, I GOP structures
 - User defined quantization matrices
 - Encoding time
 - Average bit rate
 - Active picture area selection
 - VBR and CBR

Audio

- Programmable, 24-bit, digital signal processor
- Input/Output sampling rates: 32, 44.1, 48 and 96 kHz
- Data resolution up to 24 bits/sample
- Two channel audio encoding or decoding in either MPEG (all layers) or Dolby Digital (AC-3)
- Supports stereo, joint stereo, or two mono channels
- 5.1 channels audio decoding (downmixed to two channels)
- Support for new audio algorithms via firmware

System Processor

- Based on powerful embedded ARC core
- System multiplexor and demultiplexor
- Programmable, supports encoding and decoding of DVD, VCD, SVCD, Elementary, Program, and Transport streams formats
- Programmable DMA transfer size
- Trick Play: fast and slow play forward, fast play backward

Technical overview

The CS92288 combines a programmable RISC core, programmable DSP core and dedicated processing units organized as a process pipeline. The RISC core supports system mux and demux requirements for a variety of system applications, including VCD, SVCD and DVD. The DSP supports dual-channel Dolby Digital encoding and MPEG (all layers) audio encoding and decoding. It is powerful enough to support additional audio formats, such as DTS or Dolby Pro Logic®. Integrated I²S support allows for a glueless interface to A/D and D/A converters.

MPEG Video

The CS92288 provides application program control over a large number of encoding parameters such as I, P, B-picture cadence, GOP structure and decoder buffer sizes.

Internal rate control provides a high degree of flexibility in relation to the output bit rate, including the ability to generate variable bit rate compressed video stream in one pass. This makes it suitable for storage sensitive applications such as digital camcorders and removable storage media.

Pre- and post-processing support includes pre- and post-filtering, temporal filtering, telecine (3:2 pulldown), inverse telecine, plus up and down chroma conversions.

Audio

The CS92288 supports MPEG-1 and MPEG-2 (all layers), Dolby Digital, and MP3. Additional audio compression and decompression algorithms can be supported via firmware upgrades.

Input/Output

The CS92288 can input or output MPEG-compliant program streams or audio and video elementary streams. Transport stream generation and decoding is also available via optional firmware upgrade.

Interfaces

The CS92288 includes a 64-bit SDRAM memory interface, video, and audio interfaces (with I²S), a 16-bit/8-bit Motorola/Intel host interface, a serial EPROM/Flash memory interface and JTAG.

Format Support

The CS92288 supports all the requirements of the VCD and Super VCD specifications. This includes MPEG-1 and MPEG-2 encoding and decoding at 1/2 (VCD), 2/3 (SVCD), or full D1 (DVD) resolutions, MPEG audio encoding and decoding, and an OSD. In addition, the CS92288 supports audio/video encoding and decoding at full D1 resolution using either the Dolby Digital (AC-3) or MPEG audio specifications.

Superior Video Quality

A patented motion search engine allows the CS92288 to yield better video quality than other MPEG encoders, even when these encoders apply wider search ranges. For TV interlaced signals, the CS92288 is one of few consumer-grade MPEG codecs that support motion estimation using frame, 16x8, and field prediction. Other encoders support only frame prediction. Our support for advanced modes in motion estimation, combined with our proprietary rate-control algorithms lends to a unique level of video quality at both low and high bit rates.

Superior Audio Features

A programmable DSP supports Dolby Digital and all MPEG audio formats, including MP3.

Superior Support

Cirrus Logic provides proven reference designs for affordable, high-quality, electronic products for consumer, PC and Internet applications.

DVD Recorder Reference Design

The new DVD Recorder reference design is a fully functional Total-E™ platform based on our highly integrated video processor, the CS98200, and our leadership video encoding solution, the CS92288 MPEG-2 CODEC to help manufacturers quickly get their DVD+RW recording products to market. It has all the features of a traditional VCR plus DVD playback, random access to recordings, no tape rewinding, superior video quality, 30-second advance button for skipping content and simple video editing. This platform solution dramatically reduces the silicon cost by integrating CPUs, DSPs, and video output into the DVD processor. A complete solution, along with the front-end digital video encoding chip solution and back-end DVD decoding chip solution, the DVD Recorder platform also includes the necessary ADCs and DACs for your next consumer-entertainment product.

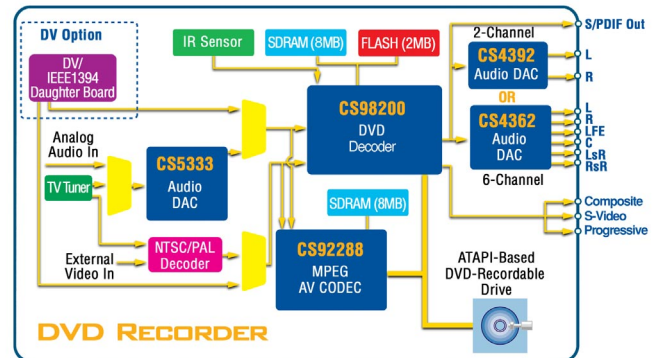

USB-DVR 2.0 Reference Design

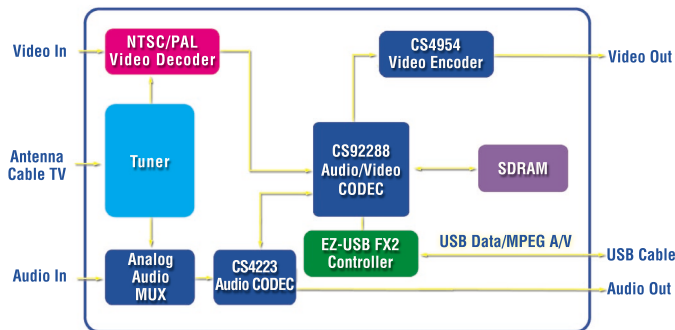

The USB DVR-2.0 is a complete reference design that makes it easy to capture, edit, view, and store audio, video and television signals on Microsoft Windows®-based personal computers with USB ports. It can output MPEG video to a computer display or a standard NTSC/PAL video monitor. Our CS92288 MPEG-2 audio/video CODEC is the heart of the reference design. It's a single chip, real-time MPEG audio/video encoder/decoder featuring a programmable system mux/demux that encodes/decodes VCD, SVCD and DVD bit-streams with frame accurate lip sync. The USB-DVR 2.0's modular design enables development of multiple PC products from a single hardware platform with a constant form factor. Now OEMs (Original Equipment Manufacturers) and ODMs (On-Demand Manufacturers) can quickly bring to market new PC DVD-focused products at competitive price points.

Cirrus Logic, Inc. Corporate Headquarters

2901 Via Fortuna
Austin, Texas 78746
USA
T: (800) 888-5016
T: (512) 851-4000
F: (512) 851-4977
www.cirrus.com

WORLDWIDE SALES OFFICES

United States
Cirrus Logic, Inc.
2901 Via Fortuna
Austin, Texas 78746
USA
T: (800) 888-5016
T: (512) 851-4000
F: (512) 851-4977

Japan
Cirrus Logic K.K.
Aioi Sonpo, Bldg. 6F
5-6 Niban-cho, Chiyoda-ku
Tokyo, Japan 102-0084
T 81-3-5226-7390
F 81-3-5226-7677

Asia Pacific
Cirrus Logic Intl. Ltd.
20F., Ocean Building
80 Shanghai Street
Kowloon, Hong Kong, China
T 852-2376-0801
T 852-2314-9920
F 852-2375-1202

Europe
Cirrus Logic U.K.
Girdler House
Quebec Road
Henley-on-Thames,
Oxfordshire RG9 1EY
United Kingdom
T: 44-1491-414-030
F: 44-1491-410-976

WORLDWIDE DISTRIBUTION

Please access our Web site, www.cirrus.com/en/contacts, for your nearest local distributor.

This datasheet has been download from:

www.datasheetcatalog.com

Datasheets for electronics components.