

SENIOR THESIS:  
WIRELESS ELECTRICITY AND IMPEDANCE MATCHING

JONATHAN RAIMAN,  
(SUPERVISED BY GREGORY OGIN, POMONA COLLEGE)

Abstract



Figure 1. Nikola Tesla's transmitter tower, death ray, or Wardenclyffe tower. [17]

In this thesis we perform impedance matching in a circuit with an inductively coupled load. We give an overview of the literature in the field of wireless power transfer and coupled mode theory in the context of electromagnetic systems. We construct an analytical model of the circuit and provide steps to minimize the phase difference between the voltage and current in our circuit and maximize the power sent to the coupled load. Finally we suggest ways to extend the experiment to improve the efficiency of the transfer and replicate the experiments performed by M. Soljagic's Research Group at MIT in 2005.

## Introduction

How do you efficiently wireless transfer power between two circuits? How do you minimize the power needed to power inductively coupled loads while maximizing the power delivered to the load? Optimization problems such as this one occur frequently when designing transformers, wireless power transfer systems, or radios, and play a significant role to understand the recent advancements made in wireless power transfer schemes, in particular those by M. Soljacic's MIT Research Group in 2005 when they transferred with 40% efficiency over 2 m using solenoid air coils or those by Intel's research labs in 2008 when they switched to 30 cm tall pancake coils and achieved over 75% efficiency. In this thesis we replicate same axis wireless power transfer across two inductively coupled circuits at 1 kHz and provide suggestions to extend this experiment to more closely replicate the experiments carried out at MIT and Intel.

This thesis is organized as follows. First we will introduce the theory behind impedance matching, by analyzing the frequency component of the different parts of our circuit. We then give a brief introduction to coupled mode theory in the context of electromagnetic systems by considering resonating coils. Then we give an overview of the common emitter amplifier that is used to strengthen the signal we want to transfer. We then perform adjustments on our circuit to compensate for some of its design flaws until it performs as intended. We compare our predicted circuit behavior with the experiment. Our experiment's behavior agrees with our theoretical model. Finally we suggest several ways to extend this experiment to explore higher frequency behavior and approach more closely the experiments done at MIT and Intel.

## Background

### History.

The majority of the field of wireless power transfer was fathered by Nikola Tesla through his many inventions, and most notably alternating current and radio. Using AC current and coils he was able to demonstrate incandescent bulbs lit wirelessly in 1894 [16]. This method has been largely reproduced and many how-to guides exist online today [20]. However inductive methods and electromagnets rely on field that decay fast as function of distance and are thus are best suited for short distance transfers or in transformers using an iron core[6].

Tesla was well aware of these limitations despite his access to a nearly unlimited power for his own experiments while at Colorado Springs as he wrote in 1919:

It was clear to me from the very start that the successful consummation could only be brought about by a number of radical improvements. Suitable high frequency generators and electrical oscillators had first to be produced. The energy of these had to be transformed in effective transmitters and collected at a distance in proper receivers. Such a system would be manifestly circumscribed in its usefulness if all extraneous interference were not prevented and exclusiveness secured. . .

Indeed he considered his earlier inventions building blocks for his later experiments with high frequency generators and larger scale transmission schemes [1, 14]. In particular one of his famous high frequency apparatus was the tesla coil [15] which

helped develop his theory of radiant energy that culminated in the construction of the Wardenclyffe tower. This tower was meant to become a global communications and energy transfer system with 30 towers spread around the globe [16, 14]. Unfortunately due to lack of funding<sup>1</sup>, a falling-out with Westinghouse, and Tesla's progressive mental and physical health deterioration this scheme was never implemented.

Current State of the Art (2005/2008).

In 2005 Prof. Marin Soljagic's research group at MIT rebooted the efforts for wireless electricity over medium and long range by using evanescent wave coupling<sup>2</sup> to power a 60W light bulb using 60 cm 5-turn air coils 2 m away with 40% efficiency [7]. Unlike past inductive methods whose field decays rapidly with distance, this new scheme uses strong coupling. Strong coupling is a regime where a resonator's evanescent waves overlaps with another resonator, thereby achieving the coupling through a method akin to tunneling atop regular resonant induction, and thus strongly reducing transmission losses [2].



Figure 2. Intel's Pancake Coils in 2008

In the wake of this publication Prof. Soljagic and several colleagues from MIT founded a startup, WiTricity, where the technology would be incorporated into consumer and industry products [19]. The publication also spurred several research groups around the globe to reproduce and improve on the results. Most notably Intel achieved a transmission efficiency of 75% in 2008 by changing the geometry to a 30cm 10 turn pancake coil [9].

Past Experiment (2010).

In 2010 as a continuation of an Independent Study led by Prof. Brian Penprase and as a final project for the Electronics course taught by Prof. Dwight Whitaker I constructed 6 resonant coils, of which one was a pancake coil. The aim of the

<sup>1</sup>In 1914 Nikola Tesla signed off the deed to the tower to the owners of the New York Hotel to pay off years of late rent on the two penthouse suites he was occupying.

<sup>2</sup>An evanescent wave is the near field of an element emitting waves, where the field decays exponentially with distance. This field is used to transfer power between the primary and secondary coil of a transformer with an iron core, and behaves like quantum tunneling with electromagnetic waves instead of quantum mechanical wave functions.

project was to reproduce in part or fully the apparatus presented in 2005 by Prof. Soljacic by constructing a 9.9Mhz amplifier, a receiver and emitter couple, and lighting a lamp or an LED at a distance. As a result of this project I now have a working amplifier that can be connected to a 40V power supply, several coils, and a working prototype that can light up an LED a meter away. Coils of various sizes, geometries, and wire length were used and made little difference as emitter-coils, but considerably changed the receiver coil's resonant frequency. It therefore appears that the receiver coil is largely defined by its inductive load, while the emitter circuit can easily compensate and absorb changes in inductance. However the current scheme is inefficient and most of power does not get transmitted. I currently believe that because the resistors in the amplifier were getting very hot ( $\approx 125^{\circ}\text{C}$ ) poor load balancing of the coil is causing most of the current to be diverted. Therefore in this thesis a portion will be focused on impedance matching the previous coils to render them efficient before implementing other changes to the overall experimental setup.

## Goal

We try to replicate same-axis energy transfer as done in the published experiments by building a regular inductively coupled power transfer circuit operating at 1 kHz, and give options for improvement.

## Apparatus

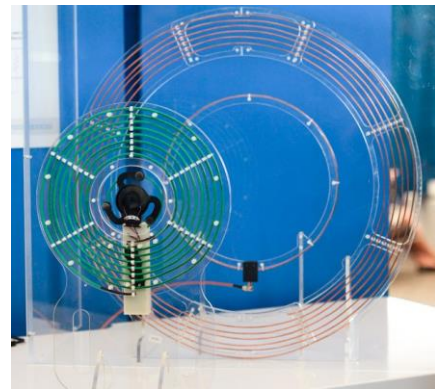
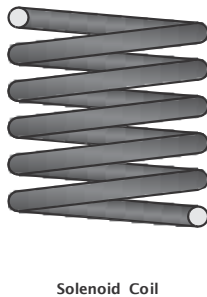
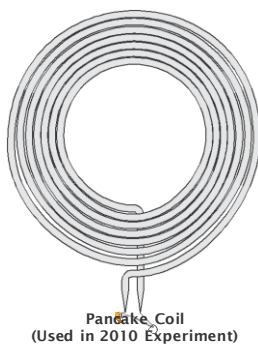

The experiment will consist of an emitter-coil and 1 receiver-coil. The emitter coil will be connected to a 40 V power supply, a custom common emitter amplifier driven at 1 kHz, and a function signal generator. The receiver will be connected to a  $100\Omega$  load, a capacitor, and the oscilloscope placed in parallel with the load to measure the voltage in the receiving coil.

The experiment requires two coax cables to connect the amplifier to the antenna and the signal source and the construction of a 200-turn emitter coil ( Figure 3), and one of the coils originally used in the 2010 experiment.



Figure 3. Emitter coil, 10.5 cm radius, 200 turns of magnet wire.

### 1. Theory: Impedance Matching

High frequency circuits carry many additional phenomenon over their DC or low frequency counterparts: most notably circuit elements that were constant and resistive, such as resistors, now have a variable resistance due to the skin effect. Loops within the circuit can also become inductors and capacitors by virtue of their geometric shape. Therefore great care must be taken to design a circuit that has a predictable behavior despite these effects.

A circuit in the gigahertz range faces two problems: the skin depth will become very small making the resistance of the circuit huge and leading to larger internal resistive losses, and the small wavelength (0.3 m at 1 Ghz, vs 300 km at 1 kHz) will cause any wire longer than  $\lambda = \frac{c}{f}$  to become an antenna.

In this thesis we will be impedance matching a circuit operating in the kHz range, thereby avoiding many issues that become significant at higher frequencies.

#### Description of the Problem

In high frequency circuits there arises a problem of impedance matching: components of the circuit gain a non-resistive aspect that causes signals traveling within to shuttle large currents that are out of phase with the voltage, and therefore do no useful work in the circuit. To achieve maximal power transfer the circuit must be impedance matched to minimize these effects.

The circuit we are considering is a driving coil with some inductance  $L_1$  and self-capacitance  $C_1$ , along with some resistive portion  $R_{\text{coil}}$ . The receiving coil also has an associated inductance  $L_2$ , and a resistance associated to the load and the coil  $R_L$ .

The coils are have a mutual inductance  $M$ , and a current  $I_{\text{in}}$  enters the driving coil's circuit at a voltage  $V_{\text{in}}$ , and enters the driving coil with a voltage  $V_1$  and a current  $I_1$ . We denote  $V_2$  the voltage in the receiving coil with a current  $I_2$ . These elements are visible in the circuit diagram below ( Figure 4).

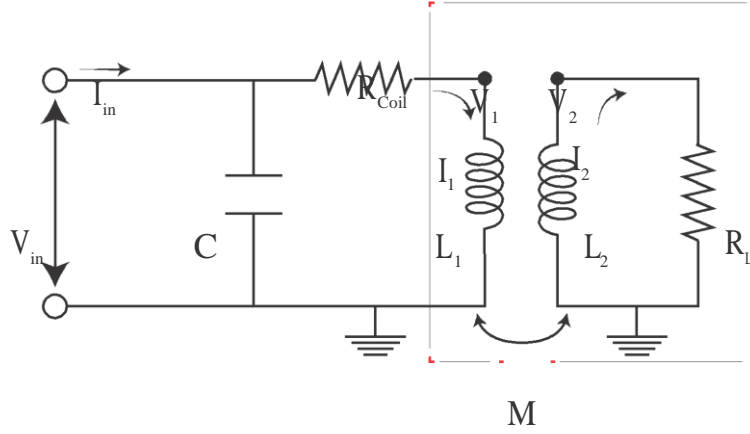

Figure 4. Circuit diagram of the driving coil and receiving coil

This model can be made more complicated in order to include the capacitance between other parts, the self-capacitance of the coils, and the overall inductance of the loops of wire throughout. However we will focus our attention on this simplified circuit to gain insight into the problem and a workable model in the kHz regime.

### 1.1. Circuit Analysis

We will work in the Fourier domain to analyze our circuit. We first need express the equivalent impedance of our circuit  $Z_{eq}$ . For the purposes of this thesis a circuit is impedance matched if  $Z_{eq}$  is purely resistive, a real number. We can also express  $Z_{eq}$  in terms of the current and voltage entering the circuit:

$$Z_{eq} = \frac{V_{in}}{I_{in}}$$

Using Kirchoff's circuit laws, which state that the sum of all currents meeting at a point is zero – all current entering a point must exit, we can find  $Z_{eq}$ . Let us first find the equivalent impedance for the boxed portion of the circuit:

$$\sum_{k=1}^{\infty} I_k = 0$$

In the time domain, where  $M$  is the mutual inductance, and  $L_1$  and  $L_2$  are the inductance of the emitter and receiver coil, respectively, the equations are:

$$(1) \quad V_1 = L_1 \frac{dI_1}{dt} - M \frac{dI_2}{dt}$$

$$(2) \quad V_2 = L_2 \frac{dI_2}{dt} - M \frac{dI_1}{dt}$$

$$(3) \quad V_2 = I_2 R_L.$$

We can now Fourier transform these three equations, where  $\omega$  is the angular frequency of the time varying input current:

$$(4) \quad V_1 = i\omega L_1 I_1 - i\omega M I_2$$

$$(5) \quad V_2 = i\omega L_2 I_2 - i\omega M I_1$$

$$(6) \quad V_2 = I_2 R_L.$$

We now want to find the equivalent impedance  $Z_{\text{ind}} = \frac{V_1}{I_1}$  by expressing  $I_2$  and  $V_2$  in terms of  $V_1$  and  $I_1$  and the circuit component values:

$$\begin{aligned} I_2 R_L &= i\omega L_2 I_2 - i\omega M I_1 \\ I_2 (R_L - i\omega L_2) &= -i\omega M I_1 \\ I_2 &= \frac{-i\omega M I_1}{R_L - i\omega L_2}, \end{aligned}$$

we can now take our expression for  $I_2$  and replace it in our equation for  $V_{\text{in}}$ :

$$\begin{aligned} V_1 &= I_1 \left( i\omega L_1 - \frac{\omega^2 M^2}{R_L - i\omega L_2} \right) \\ \frac{V_1}{I_1} &= Z_{\text{ind}} = i\omega L_1 - \frac{\omega^2 M^2}{R_L - i\omega L_2}. \end{aligned}$$

We have now obtained an equivalent impedance for the inductive part of the circuit,  $Z_{\text{ind}}$ , and we must now add in the capacitor  $C$  and resistor  $R_C$  to find  $Z_{\text{eq}}$ :

$$\begin{aligned} \frac{1}{Z_{\text{eq}}} &= \frac{1}{i\omega C} + \frac{1}{R_C + Z_{\text{ind}}} \\ &= i\omega C + \frac{1}{R_C + Z_{\text{ind}}} \\ Z_{\text{eq}} &= i\omega C + \frac{1}{R_C + Z_{\text{ind}}}^{-1} \end{aligned}$$

$Z_{\text{eq}}$  can be expressed as a function of  $C, L_1, L_2, M, \omega, R_L$ . We can find experimentally what the actual self-capacitance and self-inductance of the coils that were prepared in the past.

## 1.2. Inductance

1.2.1. Mutual Inductance. The receiver and the emitter coil share a geometric property  $M$ , the mutual inductance of the coils. This property relates how a change in flux in one coil reflects a change in current in the other. The relation is given by Neumann's formula for two loops of wire with several turns each:

$$(7) \quad M = \frac{\mu_0}{4\pi} \frac{\int_{C_{\text{emitter}}} \mathbf{I}_{\text{emitter}} \cdot d\mathbf{s}_{\text{emitter}} \int_{C_{\text{receiver}}} \mathbf{I}_{\text{receiver}} \cdot d\mathbf{s}_{\text{receiver}}}{|\mathbf{R}_{\text{emitter,receiver}}|} = k \frac{\mathbf{P}}{L_1 L_2},$$

where  $k$  is a factor between 0 and 1 that depends on the geometry of the coils and their relative positions. We can estimate  $\frac{\mathbf{P}}{L_1 L_2}$  by calculating the self inductance  $L$  of the coils.

1.2.2. Self Inductance. We can also find the inductance of each coil from the following equation with  $r$  the radius of the coil,  $N$  the number of turns,  $s$  the spacing between coils,  $a$  the wire thickness, and  $H$  the height of the coil ( $N \times$  (  $\underbrace{\text{spacing between coils}}_{=s}$  + wire thickness ) -  $s$ ):

$$(8) \quad L \approx \frac{\mu_0}{4\pi} \frac{I \cdot I}{C \cdot C^0} \frac{ds \cdot ds^0}{|R|} \Big|_{|R| > a/2} \approx \frac{N_{\text{turns}}^2 \times r^2}{9r + H} = \frac{N_{\text{turns}}^2 \times r^2}{9r + N \times (a + s) - s}$$

The coils currently built have wire thickness  $a \approx 5$  mm,  $s \approx 1$  mm, and  $r \approx 30$  cm. Therefore:

$$L \approx 3.5\text{mH}$$

### 1.3. Resistance

1.3.1. Coil Resistance. Both coils are made of copper and are subject to time varying current, therefore they will exhibit the skin effect. In conductors subject to Alternating Current the variation in magnetic field at the center causes an EMF to favor electron concentration on the outskirts of the conductor, on the skin. Therefore a conductor's actual conducting area is reduced and the resistivity of the wire at high frequency goes up with frequency.

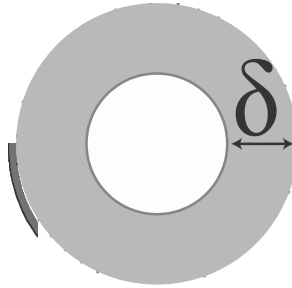

The skin depth in a wire at frequency  $f$ , permeability  $\mu$ , and conductivity  $\sigma$ :

$$(9) \quad \delta = \sqrt{\frac{1}{\pi f \mu \sigma}}$$

At low frequencies the skin depth is so deep that it does not affect the actual area the current will travel in, however a higher frequencies this effect becomes more pronounced (Table 1).

Table 1. Skin depth in a copper wire at different frequencies

Frequency (Hz)	$10^3$	$10^6$	$10^9$
$\delta$ ( $\mu\text{m}$ )	2061.6648	65.1956	2.0617

At Mhz and Ghz frequencies the skin depth is much shallower than the thickness of our wire. However at 1 kHz the skin depth is close to 2 mm, or about the thickness



of our wire, so it has no effect in our circuit. We can therefore calculate the resistance of our coil of 200 turns with 14 gauge wire, with wire diameter 1.628mm, radius  $\approx 10.5$  cm, and using the resistivity of copper at  $20^\circ$   $\rho_{20^\circ} = 1.68 \times 10^{-8} \Omega \cdot \text{m}$ , by using Ohm's law:

$$\begin{aligned} R_C &\approx \rho_{20^\circ} \cdot L/A = \frac{\rho_{20^\circ} \cdot 2\pi \cdot 10.5 \text{cm} \cdot 200}{\pi \cdot 0.000814^2} \\ &\approx 1.09 \Omega \end{aligned}$$

When we measured our coil's resistance we found that it is in fact  $1.7 \Omega$ . We can attribute this difference to the wire, which was slightly bent and damaged during the winding and construction of the solenoid.

#### 1.4. Power

In the context of power transfer between coils the best circuit is the one that will maximize the power expended in the load, and minimize the power lost in the coil. Therefore in this section we will consider the power expended overall, across the emitter-coil  $R_C$ , and across the receiving load and coil  $R_L$ .

We assume that  $V_{in}$  is a sinusoidal input of the form:

$$V_{in} = V_0 e^{i\omega t},$$

then to find the power delivered to the circuit we consider  $V_{rms}$  and  $I_{rms}$ , where the current and the voltage are out of phase by some phase  $\phi$ . Minimizing  $\phi$  will insure that the power delivered is maximized. The power that is actually needed to drive the circuit is  $P_{apparent}$ , while the power that does useful work in the circuit as opposed to being shuffled back and forth in the inductor is the  $P_{delivered}$  which depends on the cosine of the phase  $\phi$ .

$$\begin{aligned} V_{in}(\omega) &= V_0 e^{i\omega t} \\ I_{in} &= \frac{V_0 e^{i(\omega t + \phi)}}{Z_{eq}} \\ I_{in \text{ rms}} &= \frac{V_0 \sqrt{2}}{|Z_{eq}|} \\ P_{apparent} &= V_{rms} I_{in \text{ rms}} \\ &= \frac{V_0}{\sqrt{2}} I_{in \text{ rms}} \\ &= \frac{V_0^2}{2|Z_{eq}|} \\ (10) \quad P_{delivered} &= P_{apparent} \cos(\phi) \end{aligned}$$

If we define the voltage coming in,  $V_{in}$ , to have no phase, then  $\phi$  is the argument of the root-mean squared of the current:

$$\phi = \text{Arg}(I) = \text{Arg} \frac{V_{rms}}{Z_{eq}}.$$

To find the power dissipated through the receiver we proceed as follows:

$$\begin{aligned}
 I_{1 \text{ rms}} &= I_{\text{in rms}} - (\text{current through capacitor}) \\
 &= \frac{V_0}{|Z_{\text{eq}}|} - \frac{V_0}{i\omega C} \\
 I_{2 \text{ rms}} &= \frac{-i\omega M}{R_L - i\omega L_2} I_{1 \text{ rms}} \\
 V_{2 \text{ rms}} &= I_{2 \text{ rms}} R_L \\
 &= \frac{-i\omega M}{R_L - i\omega L_2} R_L I_{1 \text{ rms}} \\
 P_{\text{receiver(delivered)}} &= \frac{V_{2 \text{ rms}}^2}{R_L}
 \end{aligned}$$

and again by combining we find the receiver's power to be the following:

$$\begin{aligned}
 P_{\text{receiver(delivered)}} &= \frac{-i\omega M}{R_L - i\omega L_2} \frac{R_L^2}{R_L} I_{1 \text{ rms}}^2 \\
 &= \frac{-i\omega M}{R_L - i\omega L_2} \frac{R_L^2}{R_L} \frac{V_0}{|Z_{\text{eq}}|} \sqrt{\frac{1}{2}} - \sqrt{\frac{1}{2}} \frac{V_0}{i\omega C} \\
 (11) \quad P_{\text{receiver(delivered)}} &= \frac{V_0^2}{2} \frac{-i\omega M}{R_L - i\omega L_2} \frac{R_L}{R_L} \frac{1}{|Z_{\text{eq}}| - |i\omega C|}
 \end{aligned}$$

### 1.5. Capacitance

Using Mathematica we plot the power delivered to the circuit. If we take  $M = 0$  then the circuit we are modeling is a tank circuit. We can check that our model behaves as expected in this case by comparing a tank circuit's power vs frequency plot to our circuit's power vs frequency plot when  $M = 0$ :

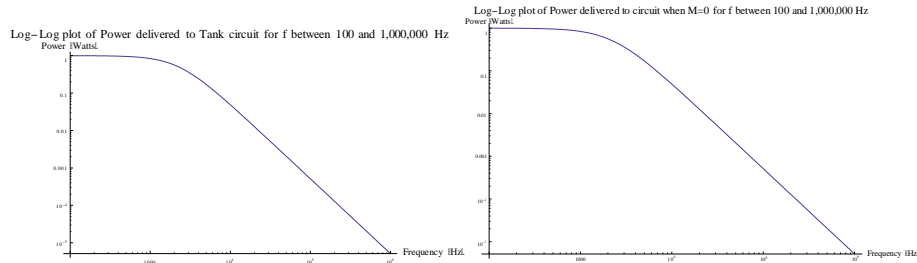

(a) Tank circuit, with  $R = 50\Omega, L_1 = 3511\mu\text{H}, C = 1000\mu\text{F}$

(b) Our circuit, with  $R = 50\Omega, L_1 = 3511\mu\text{H}, M = 0, L_2 = 30\mu\text{H}, C = 1000\mu\text{F}$

**Figure 5.** When the mutual inductance is 0 our circuit's power dissipation is the same as a tank circuit's power dissipation.

The model behaves as expected. We can now introduce the coupled circuit by setting the mutual inductance to be some value defined by the geometric factor  $k$

and our coil's self-inductances. If  $k = 1$ , then all the flux leaving one coil enters the other, however if the coils are spaced apart by some amount this is no longer true. Finally if the coils are placed perpendicular to each other and on the same axis, then none of the flux exiting the first coil enters the receiving coil and in this case  $k = 0$ . For our purposes we are assuming the coils are facing each other and concentric, at some short distance relative to the coil diameter such that  $k = 0.5$ . When this is true we can now compare the power delivered to the load for various capacitances and inductances (Figure 7).

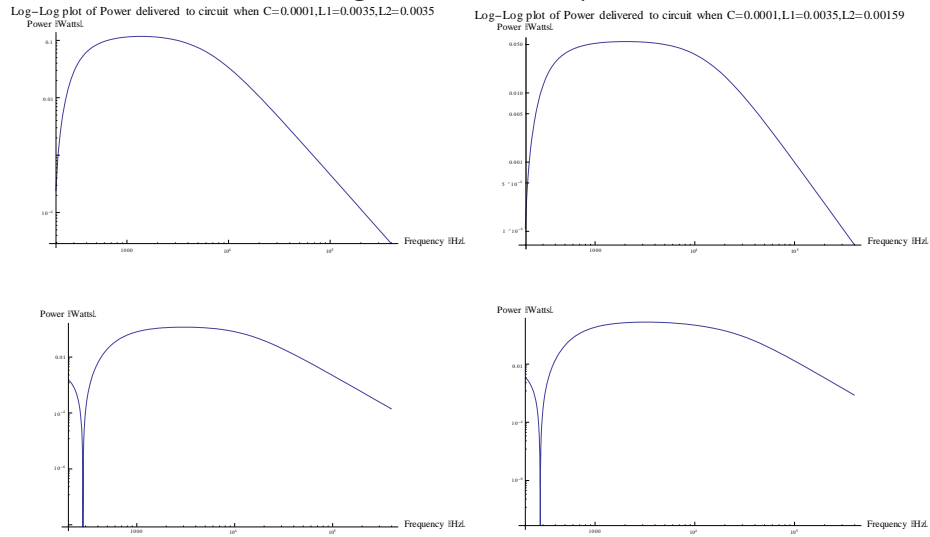
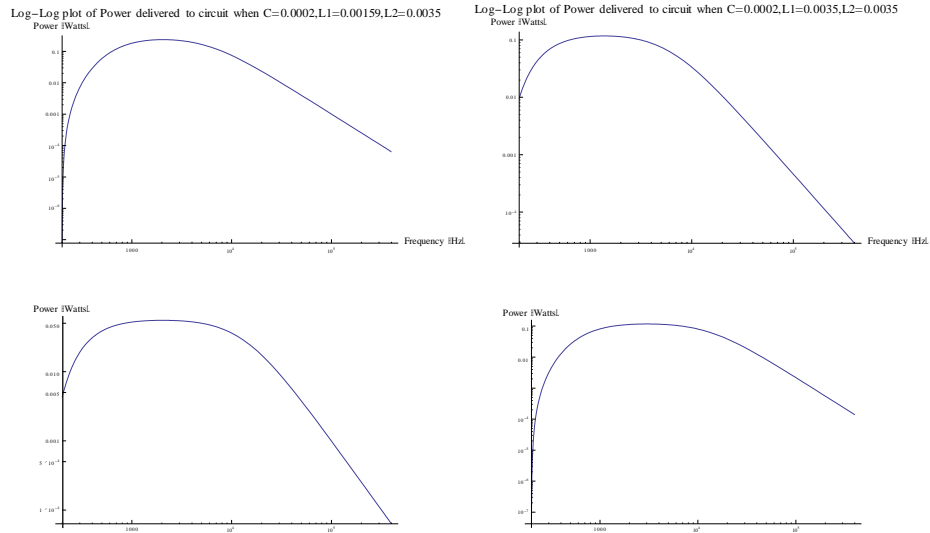
Figure 6.  $C_1 = 1000\mu\text{F}$ Figure 7.  $C_1 = 2000\mu\text{F}$ 

In the plots above we see that increasing the capacitance broadens the optimum operating frequency range but does not change the resonant frequency of our circuit. Increasing the inductance of the emitter coil,  $L_1$ , raises the resonant frequency, and

varying the inductance of the receiver coil,  $L_2$ , reduces the optimum operating frequency range.

## 2. Coupled Mode Theory

In this thesis we only perform analysis based on lumped circuit elements  $L$ ,  $C$  and  $R$ , however the circuits studied built for the experiments done at MIT and Intel [7] rely on coupled mode theory. To gain insight into the high levels of power transfer efficiency achieved in their experiments and to understand how this differs from inductive schemes like those found in transformers we provide a brief overview of couple mode theory.

### 2.1. Energy in coupled resonators

In coupled mode theory the total energy of each resonator within a group is described by a complex amplitude scaled so that the square of the absolute value of this amplitude is equal to the total energy stored in this resonator. The resonator is then defined by a resonant frequency – the imaginary part of the amplitude – and a real part that represents its dissipation of power – losses and power taken up by a load.

To understand this better let us consider the amplitude of the  $n^{\text{th}}$  such resonator in a system, which we call  $a_n(t)$ , where  $\omega_n$  is the frequency of this resonator, and  $a_m(t)$  is the complex amplitude of the  $m^{\text{th}}$  other resonators interacting with coupling coefficients  $\kappa_{nm}$ , and  $\Gamma_n$  is the decay constant of this resonator – the rate at which power is dissipated through Ohmic losses, radiation, and delivered to the load. The rate of change of this amplitude is:

$$\dot{a}_n(t) = i(\omega_n + i\Gamma_n)a_n(t) + \sum_{m=n} i\kappa_{nm}a_m(t) + F_n(t).$$

Furthermore let us note that André Kurs shows in [8] that  $\kappa_{nm} = \kappa_{mn}$ , and  $\kappa_{mn}$  is real. Lastly, let us note that  $F_n(t)$  is the driving term in the system – this is the source that powers the set of resonators.

In the case of an uncoupled and undriven oscillator we can find  $a_0(t)$ , the complex amplitude as follows:

$$a_0(t) = e^{-i\omega_0 t - \Gamma_0 t},$$

where  $\omega_0$  is the resonant frequency of this oscillator, and  $\Gamma_0$  is the decay constant in this oscillator due to absorption and electromagnetic radiation.

### 2.2. Efficiency and Eigenfrequency splitting

Here we present the method developed in André Kurs's master thesis [8] on coupled mode theory for finding the eigenfrequencies of the system and how to determine the efficiency of the system based on the separation between the different eigenfrequencies.

Let us consider a similar case to the one we are studying where we have a source with some complex amplitude  $a_S(t)$  and a driven element (receiver coil in our case) with complex amplitude  $a_D(t)$ . We can apply our equation for the time varying amplitude to these elements:

$$\begin{aligned}\dot{a}_S &= -i(\omega_S - i\Gamma_S)a_S - i\kappa a_D \\ \dot{a}_D &= -i(\omega_D - i\Gamma_D)a_D - i\kappa a_S.\end{aligned}$$

From these two differential equations we can now eigenfrequencies for the system:

$$\begin{aligned}\omega_1 &= \frac{1}{2}[\omega_S + \omega_D - i(\Gamma_S + \Gamma_D)] + \frac{1}{2} \sqrt{4\kappa^2 + (\omega_S - \omega_D)^2 (\Gamma_S - \Gamma_D)^2 - 2i(\Gamma_S - \Gamma_D)(\omega_S - \omega_D)}^{1/2}, \\ \omega_2 &= \frac{1}{2}[\omega_S + \omega_D - i(\Gamma_S + \Gamma_D)] - \frac{1}{2} \sqrt{4\kappa^2 + (\omega_S - \omega_D)^2 (\Gamma_S - \Gamma_D)^2 - 2i(\Gamma_S - \Gamma_D)(\omega_S - \omega_D)}^{1/2}.\end{aligned}$$

In the experiment performed at MIT the resonators are two identical coils of copper tubing, therefore they have  $\omega_S = \omega_D = \omega_0$  and  $\Gamma_S = \Gamma_D = \Gamma$ , and more generally in the case of identical resonators these eigenfrequencies greatly simplify to:

$$\omega_{1,2} = \omega_0 - i\Gamma \pm \kappa.$$

Therefore we note that the two frequencies are split by 2 times the coupling coefficient,  $2\kappa$ .

The same method can be applied to a driven case, where we drive the source with some sinusoidal input  $F e^{i\omega t}$ , and we get:

$$\begin{aligned}a_S &= \frac{[\Gamma_D - i(\omega - \omega_D)] F e^{-i\omega t}}{\kappa^2 + \Gamma_S \Gamma_D - (\omega_S - \omega)(\omega_D - \omega) + i[\Gamma_S(\omega_D - \omega) + \Gamma_D(\omega_S - \omega)] - i\kappa F e^{-i\omega t}} \\ a_D &= \frac{-i\kappa F e^{-i\omega t}}{\kappa^2 + \Gamma_S \Gamma_D - (\omega_S - \omega)(\omega_D - \omega) + i[\Gamma_S(\omega_D - \omega) + \Gamma_D(\omega_S - \omega)]}\end{aligned}$$

Solving again for the frequencies in the case of identical coils we obtain:

$$\omega_{1,2}^0 = \omega_0 \pm \sqrt{\kappa^2 - \Gamma^2}.$$

It is therefore possible to calculate  $\kappa$  and get the frequency splitting by experimentally measuring the rate of power dissipation  $\Gamma$  in the coils.

Using this parameter it is then possible to find the efficiency of the transfer by considering the power lost in the driven coil versus the power in the receiver coil.

The decay constant in the driven coil is the sum of the decay constant due to radiation and ohmic losses,  $\Gamma_D$ , and another constant related to the power going towards a load,  $\Gamma_L$ , which we can group into a new decay constant:  $\Gamma_D^0 = \Gamma_D + \Gamma_L$ . The power delivered to the load is thus  $\Gamma_L |a_D|^2$ . The efficiency  $\eta$  is then the ratio of this power to the overall power lost in the system:  $\Gamma_S |a_S|^2 + (\Gamma_D + \Gamma_L) |a_D|^2$ :

$$\begin{aligned}\eta &= \frac{\Gamma_L |a_D|^2}{\Gamma_S |a_S|^2 + (\Gamma_D + \Gamma_L) |a_D|^2} \\ &= \frac{\Gamma_L \kappa^2}{\Gamma_S [(\Gamma_D + \Gamma_L)^2 + (\omega - \omega_D)]^2 + (\Gamma_D + \Gamma_L) \kappa^2},\end{aligned}$$

The denominator is minimized when  $\omega = \omega_D$  – when the coils are driven at resonance. In this case the equation for efficiency reduces to:

$$\eta = \frac{(\Gamma_L/\Gamma_D)\kappa^2/(\Gamma_S\Gamma_D)}{[1 + \Gamma_L/\Gamma_D]\kappa^2/(\Gamma_S\Gamma_D) + [1 + \Gamma_L/\Gamma_D]^2}.$$

In this case maximizing the efficiency is equivalent to impedance matching the circuit by varying the elements in the driven and source circuit [8, 18]. In this case we find that the efficiency is maximized when  $\Gamma_L = \Gamma_D \sqrt{1 + \kappa^2/\Gamma_S\Gamma_D}$ . Efficiency therefore depends on the dimensionless parameter  $\kappa/\sqrt{\Gamma_S\Gamma_D}$ . In fact we find that the efficiency is a curve that asymptotes to 1 as  $\kappa/\sqrt{\Gamma_S\Gamma_D}$  goes to infinity [8] as shown in Figure 8.

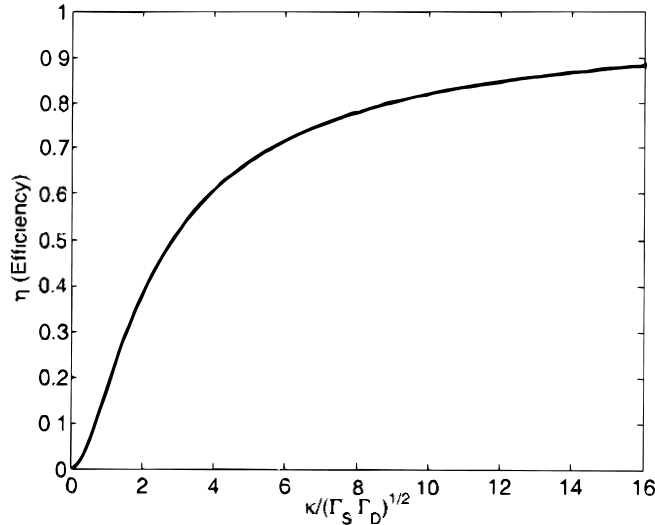

Figure 8. Efficiency of transfer between source and driven element as a function of  $\kappa/\sqrt{\Gamma_S\Gamma_D}$  (Source André Kurs [8]).

The transfer therefore becomes efficient when  $\kappa \geq \sqrt{\Gamma_S\Gamma_D}$ . André Kurs gives an excellent description of the intuition behind this solution:

$\sqrt{\Gamma_S\Gamma_D}$  is essentially the rate at which the source and device dissipate energy, while  $\kappa$  is a measure of how fast the two objects exchange energy. If  $\kappa \geq \sqrt{\Gamma_S\Gamma_D}$ , then the energy travels from the source to the device before too much of it gets wasted away.

Indeed as the ratio of power exchange to that lost during any time interval grows, then so does the efficiency of the transfer. To be concrete this means that circuits made of two resonators – similar to the constructed for this thesis – with similar dimensions and parameters as those used by MIT, when impedance matched and tuned at a frequency between 1-50MHz (this range is identified as optimal in [8, 7, 10] for these parameters) then the power delivered to the load will be greater than the power lost to radiation and dissipation during a given time interval.

### 3. Theory: Amplifier

#### 3.1. Common Emitter Amplifier

In the idealized circuit we consider earlier we ignored how the voltage source is generated. In the actual circuit our function generator has a high impedance and is not capable of maintaining the signal we want. We therefore use a common emitter amplifier to decrease the impedance of our function generator and create a more robust voltage source that oscillates at the frequency we want. We include below a diagram of the amplifier and the voltage source:

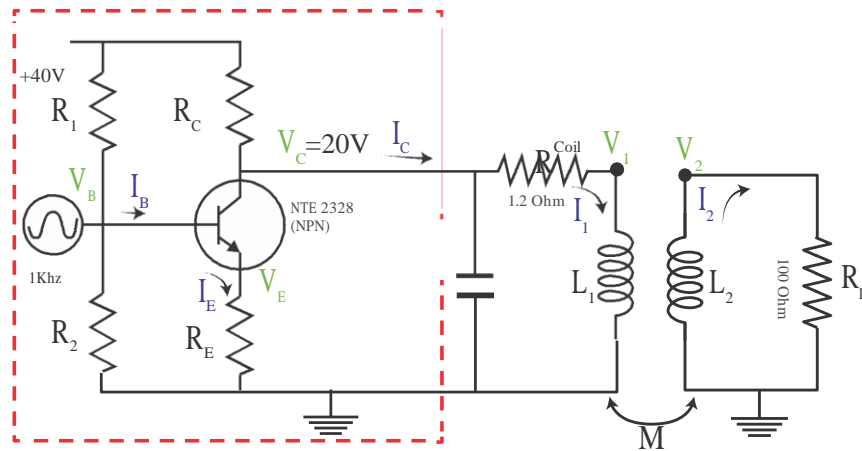

Our function generator outputs a signal with amplitude 1V. If we want to have an amplitude of 10V in our inductor and our input is 1V, then we need 10× gain. To achieve this we use an active component, an NPN transistor. These transistors take a small current entering the base, and turn it into a large current at the collector and the base. From the following properties of a transistor we can design a common emitter amplifier that amplifies our function generator's output and gives us lower output impedance so that we can power our coil. To do so we need a quiescent voltage – the voltage when there is no signal coming in – to be as close as possible to half of the voltage coming in to give our output the greatest range possible ( $\pm 10V$ ):

$$\text{Voltage Gain} = \frac{V_{\text{out}}}{V_{\text{in}}} = 10,$$

$$V_C = 20 \text{ V}$$

If we make some assumptions about our transistor we can solve for the resistor values  $R_1$ ,  $R_2$ ,  $R_E$ , and  $R_C$ :



$$\begin{aligned}\text{Voltage Gain} &\approx -\frac{R_C}{R_E} \\ 0.05 \cdot R_C &\approx R_E \\ I_C &\approx I_E \\ I_C R_C &= 20 \text{ V},\end{aligned}$$

Finally in a transistor the following relationship holds:

$$V_E + 0.60 \text{ V} = V_B,$$

Finally we call  $R_1$  and  $R_2$  a voltage divider that biases the amplifier. We can ignore  $R_E$  and  $R_C$  when calculating the values for  $R_1$  and  $R_2$  if the current going into the base,  $I_B$  is negligible, or equivalently if  $R_E$  is much larger than  $R_2$ . Transistors exhibit a form of “lensing”<sup>3</sup> where the impedance of the resistor  $R_E$  appears larger to the voltage divider by a multiplication by the factor  $\beta$ .

$\beta$  is a property of the transistor, and for our purposes our transistor an NPN NTE 2328 has  $\beta$  between 55 and 160. It is often assumed that  $\beta = 75$  however it does not matter specifically what value  $\beta$  is as long as we assume that it is somewhere between 60 and 100, which is true within the regime we are operating at.

Because all our resistor values depend on  $R_C$  we will solve for it first. In RF circuits the impedance of the load is commonly  $50\Omega$ . In our circuit we have  $Z_{eq} = 1.2\Omega$ , but we can correct for this later by adding resistors in series, so we can assume that a load comparable to the typical load of an RF circuit will be used.

$R_C$  therefore plays the role of the Thevenin resistance of our power source. Setting the thevenin resistance to be less than or equal to our load will ensure the least sag in the power source and will maximize the power delivered. If we set  $R_C = 25\Omega$ , then we can find the current we want in our collector and from there we can determine the rest of the resistances we need.

$$\begin{aligned}I_C R_C &= 20 \text{ V} \\ I_C &= 0.8 \text{ A} \\ &\approx I_E,\end{aligned}$$

Using  $I_E$  and the voltage gain we want we can find  $V_E$ :

$$\begin{aligned}\text{Voltage Gain} &\approx -\frac{R_C}{R_E} \\ R_E &= \frac{1}{10} R_C \\ &= 2.5 \approx 2.8\Omega(\text{actual}) \quad \text{lowest impedance, highest power rating available for experiment.} \\ V_E &= I_E \cdot R_E = 2.24 \text{ V} \\ V_B &= V_E + 0.6 \text{ V} = 2.84 \text{ V},\end{aligned}$$

<sup>3</sup>The transistor hides the impedance of the power source, and increases by the factor  $\beta$  the impedance of the load placed after the transistor with respect to the signal source.

We now have the resistor for our amplifier. We still need to construct a voltage divider by finding  $R_1$  and  $R_2$  such that  $\frac{R_2}{R_1+R_2} \cdot 40 \text{ V} = 2.84 \text{ V}$ . We solve for  $R_1$  and  $R_2$  below:

$$R_2 = \frac{929}{71} R_1,$$

If we set  $R_1 = 871\Omega$ , then  $R_2 = 66\Omega$ . Picking  $R_2 = 47\Omega$  is better since we want  $R_2 \ll \beta R_E = 210$ , and this does not change the ratio  $R_1 : R_2$  too much.

We are now ready to construct and test the circuit's behavior and compare it to our model.

## 4. Experiment

We assembled the amplifier and placed the emitter coil,  $L_1$ , on a non-metallic chair to ensure flux lines were not obstructed by any other material before they reach the receiver coil. The receiver coil was elevated to be concentric with the emitter coil and displaced on this axis up 3 meters away from the emitter.

We find that when setting up the coil and circuit as described above we do not get any voltage gain in the amplifier and we have a small voltage in our receiver coil. Furthermore the quiescent voltage is  $2\text{V} \pm 0.1\text{V}$  instead of the expected 20 V. Therefore the inductive method is working in principle but there remains many aspects to optimize that we describe below.

### 4.1. Quiescent Voltage

We suspect there are two design flaws that explain why the quiescent voltage is lower than we expected. First we assumed that the current going to the base of the transistor,  $I_B$ , was negligible because we assumed that  $R_2 \ll \beta R_E$ . However  $\beta R_E \approx 4 \times R_2$ , so this approximation does not appear to hold in this case. Second our amplifier cannot handle a load that has an impedance much smaller than its Thevenin resistance. Since our amplifier has a thevenin resistance of  $25\Omega$  and our coil has an impedance of  $1.7\Omega$  the power supply's output will sag unless we make this load have a higher impedance, by adding resistors in series with it for instance.

4.1.1. Improved base current circuit design. To reduce the base current we can either make  $R_E$  larger or make  $R_2$  smaller. Because a larger  $R_E$  would make  $R_C$  larger too to maintain the voltage gain we want, thereby increasing the thevenin resistance, so we can only make  $R_2$  smaller.

Simply opting for a smaller  $R_2$  would cause a huge amount of current to go through  $R_1$ . Therefore we decided to use a separate power source, a 6V alkaline battery, to supply power to the voltage divider, allowing us to use smaller values for  $R_1$  and  $R_2$ . This alternate circuit is shown in the figure below (Figure 9).

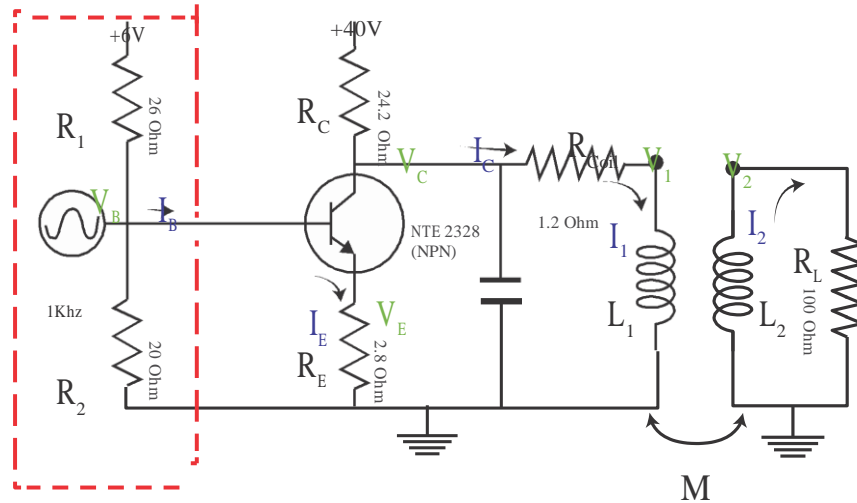

Figure 9. Voltage divider with separate power supply, lower  $R_2$ , and lower base current

In this new setup we reduce the power dropped over the resistors in  $R_1$  and  $R_2$ , while maintaining the same voltage at the base. This allows us to reduce the current going to the base by making  $R_2$  more than half as small as before, so that it becomes safe again to assume  $R_2 \approx \beta R_E$ .

4.1.2. Improved base current circuit results. After we implemented the changes in 9 we increase the quiescent voltage to  $2.67V \pm 0.05V$ . The current going to the base is  $542\mu A \pm 1\mu A$ . To have a quiescent voltage of 20V we need a collector and emitter current of 0.8A, and a load that is about equal to the collector resistance,  $R_C$ , in order for the quiescent voltage to be at half the input voltage of 40V. We found the collector current to be  $0.92A \pm 0.01A$  which will give us a quiescent voltage of 17V once we have a load that is closer to  $25\Omega$  placed after the collector resistor  $R_C$ .

Our the oscilloscope we find that the output signal is a clipped sinusoid. The quiescent voltage is still too low to allow for both the negative and positive parts of the sine wave to be reproduced and amplified:

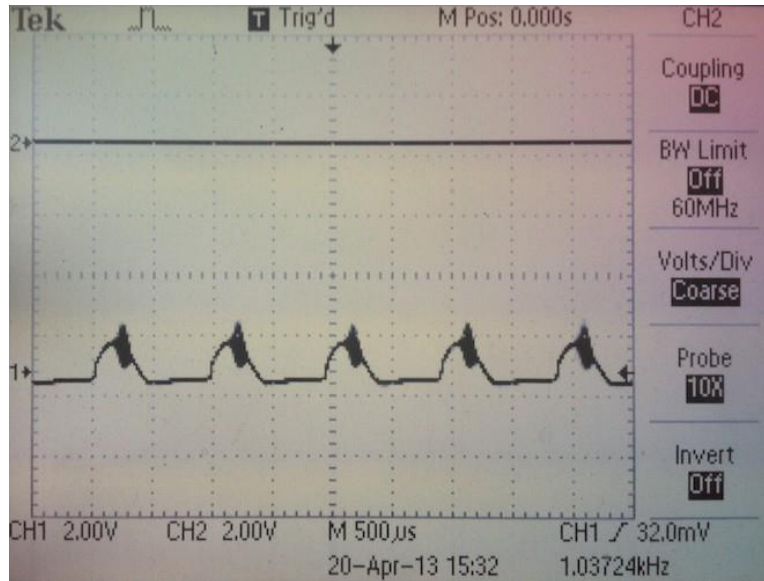

Figure 10. Voltage after amplification seen at the coil is a clipped sinusoid

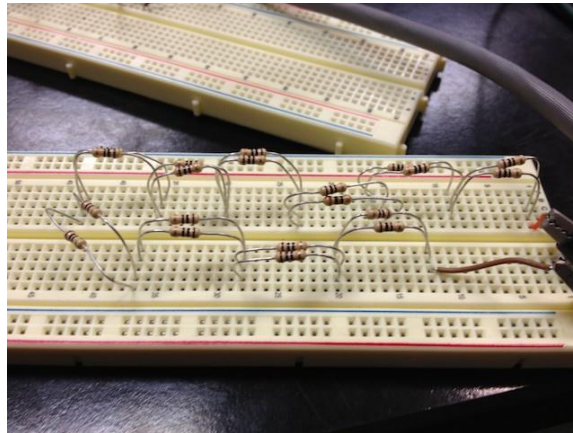
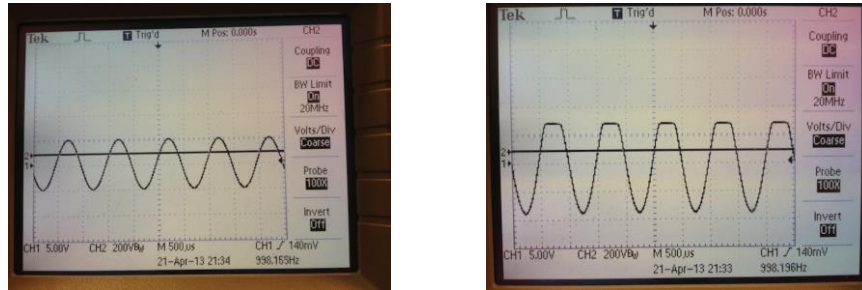

Figure 11.  $50\Omega$  distributed across 20  $10\Omega$  resistors.

4.1.3. Increasing load circuit design. The other design flaw we faced was that our coil's impedance did not match the output impedance of our amplifier. Due to time constraints we did not construct a coil with a higher impedance and did not have a lower impedance amplifier to use. We instead added resistors in series with the coil to raise the impedance of the load. The power that goes through these resistors is wasted, but this solution allows us to test the behavior of the circuit just the same. This addition raised the quiescent voltage to  $19.9V \pm 0.1V$ , precisely where we intended our quiescent voltage to be. The oscilloscope showed a full sine

wave amplified 5 times without clipping (Figure 12a), and 10 times with some clipping in the circuit at +8V (Figure 12b).



(a) Voltage Gain  $\approx 5$ , remains sinusoidal (b) Voltage Gain  $\approx 10$ , Clipped sinusoidal

Figure 12. Greater voltage gain, no visible distortion apart from clipping remaining on amplified signal in coil.

#### 4.2. Voltage in the receiver coil

We measured the amplitude of the sine wave using an oscilloscope across the receiving coil's capacitor and found that the voltage drops off as the inverse cube root of distance.

Distance (cm) $\pm 1$ cm	0	5	10	15	30.48	38.1	50.8	63.5	76.2
Voltage (mV) $\pm 20$ mV	250	225	210	200	205	250	225	210	200
Distance (cm) $\pm 1$ cm	88.9	101.6	114.3	127	139.7	152.4	165.1	292.1	
Voltage (mV) $\pm 20$ mV	200	175	170	165	150	150	150	125	

Table 2. Receiver Voltage vs. Emitter-Receiver Distance

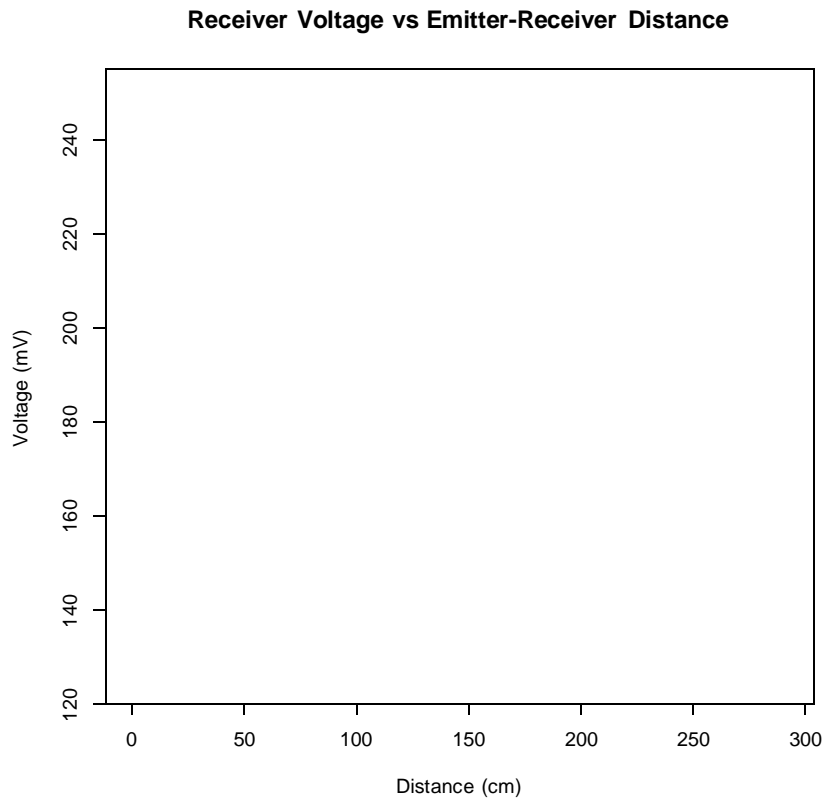

Figure 13

The 5 shortest distance measurements (in red Figure 13) were made before the rest of the measurements, and the apparatus was turned off between the two sets, so we will be ignoring these points during our the rest of our analysis. On the remaining points we perform a least squares power law fit which we plot in red below (Figure 14).

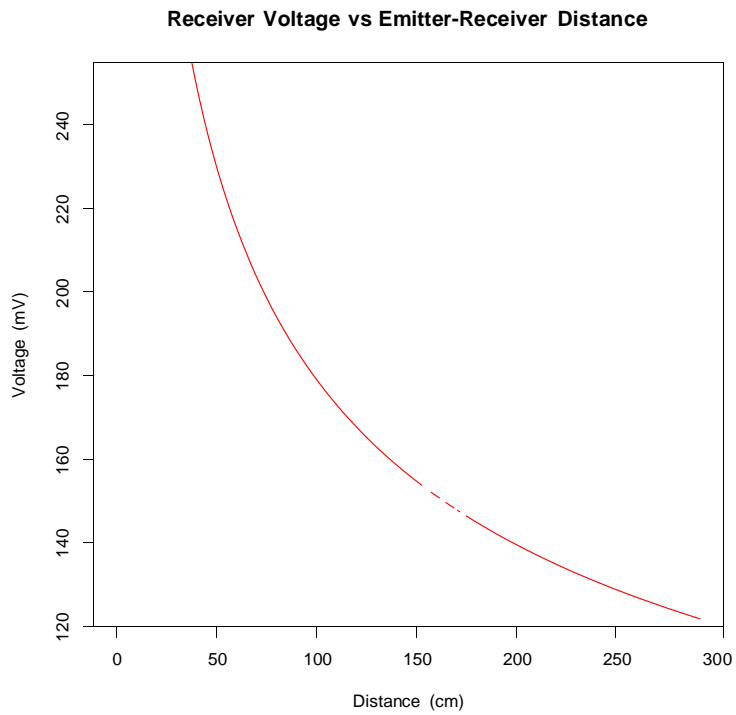

Figure 14

During the experiment we added a  $1000\mu\text{F}$  capacitor to the receiving coil to increase the charge stored in the coupled circuit. These changes are shown in the figure below, (Figure 15).

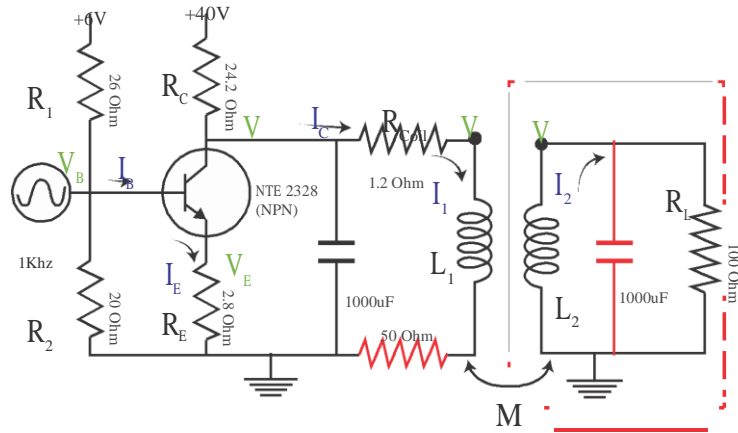
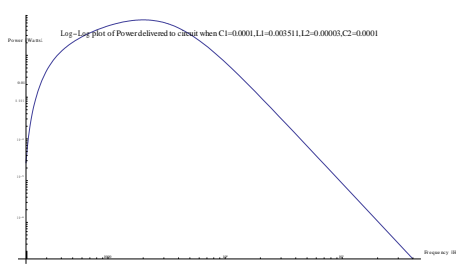

Figure 15. Circuit with amplifier, additional resistors in series with  $L_1$  and capacitor in coupled circuit

Performing the same type of analysis as in the previous section we can determine the expected power delivered to the coupled load for different capacitances in the receiving coil:



Figure 16.  $C_1 = 1000\mu\text{F}$



(a) Adding a capacitor bumped the resonant frequency higher than 1kHz

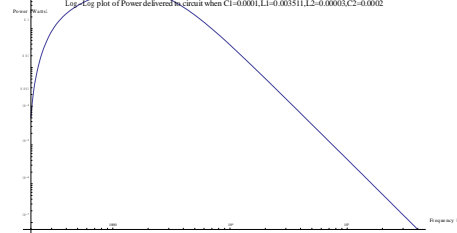

(b) Increasing the capacitance of  $C_2$  decreases the resonant frequency ( $\omega_0 = \sqrt{1/LC}$  in an RLC circuit) back to 1kHz

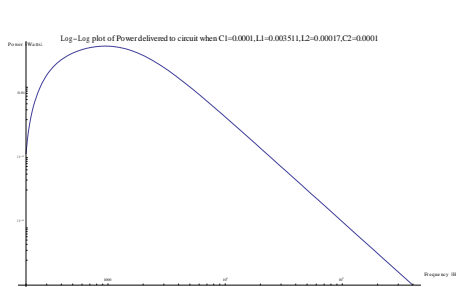

(c) Increasing the inductance of  $L_2$  also decreases the resonant frequency as expected in an RLC circuit (Figure 16b).

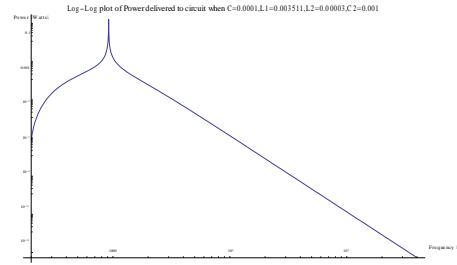

(d) Delivered power in coupled circuit different from apparent power – capacitor current and voltage no longer in phase in coupled circuit

We can see in Figure 16d that multiplying by the cosine of the phase – the argument of the complex impedance of our coupled circuit – a very sharp peak appears at 1kHz when power delivered is maximized when using a capacitance for  $C_2$  of  $10^3 \mu\text{F}$ . We need to change our equation for the power in our receiver because our load  $R_L$  is now complex. We denote it  $Z_L$  below, and recalculate the apparent power in the receiver:

$$Z_L = \frac{1}{R_L} + i\omega C_2$$

$$P_{\text{receiver apparent}} = \frac{V^2}{2} \frac{1}{|Z_L - i\omega L_2|^2} \frac{1}{|Z_{\text{eq}}|} - |i\omega C|^2$$

We can find the phase by calculating the complex impedance of our coupled circuit. To find  $Z_{\text{eq coupled}}$  we also include the inductance of the receiver coil  $L_2$  that is also responsible for the phase difference between the current and the voltage in an RLC circuit:

$$\begin{aligned}
Z_{\text{eq coupled}} &= \frac{1}{i\omega L_2} + \frac{1}{R_L} + i\omega C_2^{-1} \\
\phi_{\text{coupled}} &= \text{Arg}[Z_{\text{eq coupled}}] \\
P_{\text{receiver apparent}} &= \frac{\omega^2 M^2}{2 |Z_L - i\omega L_2|^2} |Z_L| \frac{1}{|Z_{\text{eq}}|} - |i\omega C_2|^2 \cos(\phi_{\text{coupled}}),
\end{aligned}$$

With our updated equation for the delivered power in the receiver we find that a larger capacitor in the receiver will increase the delivered power to the load.

## 5. Conclusion

Our model reasonably predicts the behavior of same-axis resonant induction between two RLC circuits at 1kHz. In particular we find the inductance of the coils is critical to efficient power transfer, while the capacitance of the receiving coils mainly affects the resonant frequency and optimum frequency range. A practical design of this system therefore could decide on a value for  $C_1$  and  $C_2$  based on the tolerances of their production, favoring a greater capacitance when the optimum frequency range needs to be greater, and a lower capacitance when the remainder of the components have greater precision.

The experiments done at MIT in 2005 and intel in 2008 were the inspiration for this experiment. There are several ways we can extend this experiment to further study the behavior the circuits used in their experiments. First our circuit is not efficient overall. The experiments done at MIT and Intel make use of coupled-mode theory to transfer energy more efficiently by exchanging power between the coils through evanescent waves in a way that is allows the power transferred and stored in the field to be greater than the one lost per cycle through Ohmic and radiative losses, allowing for efficient power transfer [10, 2, 7].

In their experiment the energy that we transfer is considered part of the radiative losses, however their scheme is most efficient once the circuit is impedance matched. Therefore applying the methodology explored in this thesis to the frequency range they recommend would allow the experimenter to replicate and explore this method. The frequency range desired corresponds to the situation where the power delivered to the load during a given time interval exceeds the losses in the source and driven element. For the dimensions and parameters used by MIT they recommend driven the circuit and using coils that have a resonant frequency between 1 and 50Mhz.

A future experiment could impedance match a circuit tuned at a megahertz frequency, where the coupled mode method is efficient. Higher frequencies introduce problems relating to the skin effect and to the behavior of loops in the circuit. In fact the oxidation on the coils used in [7] is believed by the authors to have increased the resistivity of their coils, decreasing the Q factor – bandwidth of resonant frequency. To remedy this they recommend using silver plated coils. Changes would also be needed to be made to our circuit and amplifier: the loops and wavelength-long or longer wires can act as inductors at megahertz frequencies, therefore using a more centralized design, possibly on a printed circuit board, would reduce these effects.

Finally, one might imagine our experiment could be extended to consider off-axis power transfer, and specifically improvements to the geometry of the receiver and emitter coils. In A Chiral Route to Negative Refraction by J.B. Pendry, [12], which discusses objects with negative refraction the topic of novel shapes is discussed

which could offer better resonators at smaller dimensions as described in [7], “by working with more elaborate geometries for the resonant objects.” Perhaps using omnidirectional spherical antennas allows current and future wireless power transfer techniques to remain efficient during motion, permits new configurations of charger receiver couples, such as on the move charging, and improves redundancy and reliability of small receivers where vibrations frequently cause large rotations off the transmission axis. There is strong evidence that transmission efficiency could be greatly improved through geometry given the rapid improvement of coupling efficiency from the original 40% transmission efficiency over 2 m using a solenoid shaped air coil achieved in 2005 by the M. Soljacic’s MIT Research Group to over 75% in 2008 at Intel’s research labs by switching to a 30 cm-tall pancake coil [7, 9]. A bi- or tri-axial antenna coil system allows flux to generate emf in the antenna regardless of the orientation of emitter receiver couples by using isotropism.

Appendix A.  
Mathematica Source Code

```

1 (* Our_circuit_*)
2
3 Zind[w, C, M, L1, L2, RL, RC] =
4   I*w*L1 - (w^2*M^2)/(RL - I*w*L2);
5 Zeq[w, C, M, L1, L2, RL,
6   RC] = (I*w*C + 1/(RC + Zind[w, C, M, L1, L2, RL, RC])
7   )^(-1);
8 ZeqCoupled[w, RL, C2] = (1/(RL) + I*w*C2)^-1;
9 ZeqCoupledArg[w, RL, C2, L2] =
10  Arg[(1/(I*w*L2) + 1/(RL) + I*w*C2)^-1];
11 PowerApparent[V0, w, C, M, L1, L2, RL,
12  RC] = (V0^2)/(2*Abs[Zeq[w, C, M, L1, L2, RL, RC]]);
13 PowerDelivered[V0, w, C, M, L1, L2, RL, RC] =
14  PowerApparent[V0, w, C, M, L1, L2, RL, RC]*
15  Cos[Arg[Zeq[w, C, M, L1, L2, RL, RC]]];
16 Irms[V0, w, C, M, L1, L2, RL,
17  RC] = (V0/(Abs[Zeq[w, C, M, L1, L2, RL, RC]]*2^0.5) -
18  V0/(Abs[1/(I*w*C)]*2^0.5));
19 Irms[V0, w, C, M, L1, L2, RL, RC] =
20  Abs[(-I*w*M)/(RL - I*w*L2)]*Irms[V0, w, C, M, L1, L2,
21  RL, RC];
22 PowerReceiverApparent[V0, w, C, M, L1, L2, RL,
23  RC] = (V0^2/2)*(Abs[(-I*w*M)/(RL - I*w*L2)]^2)*
24  Abs[RL]*(1/Abs[Zeq[w, C, M, L1, L2, RL, RC]] - Abs[I*w
25  *C])^2;
26 LogLogPlot[
27  PowerApparent[10, 2*Pi*f, 1000*10^-6, 0, 3511*10^-6,
28  3511*10^-6, 100,
29  50], {f, 100, 1000000},
30  AxesLabel -> {Style["Frequency (Hz)", FontSize -> 14],
31  Style["Power (Watts)", FontSize -> 14]},
32  PlotLabel ->
33  Style["Log-Log plot of Power delivered to circuit when
34  M=0 for f \
35  between 100 and 1,000,000 Hz", FontSize -> 18]]
36
37 (* Tank Circuit Comparison *)
38
39 ImpTank[w, C, L1, R] = (I*w*C + 1/(R + I*w*L1))^(-1);
40 CurrentTank[V0, w, C, L1, R] = V0/(ImpTank[w, C, L1,
41  R]);
42 LogLogPlot[
43  Abs[CurrentTank[10, 2*Pi*f, 0.0020, 30*10^-6, 5]], {f,
44  100

```

```

39 1000000}];
40 PowerTankResistor[V0_, w_, C_, L1_,
41   R_] = (V0^2)/(2*Abs[ImpTank[w, C, L1, R]]);
42 LogLogPlot[
43   PowerTankResistor[10, 2*Pi*f, 1000*10^-6, 3511*10^-6,
44     50], {f, 100,
45     1000000},
46   AxesLabel -> {Style["Frequency (Hz)", FontSize -> 14],
47     Style["Power (Watts)", FontSize -> 14]},
48   PlotLabel ->
49     Style["Log-Log plot of Power delivered to Tank circuit
50     for f \
51     between 100 and 1,000,000 Hz", FontSize -> 18]]
52 (* Power delivered to receiver with capacitor *)
53
54 Manipulate[
55   LogLogPlot[
56     PowerReceiverApparent[10, 2*Pi*f, cc, 0.5*(L1*L2)^0.5,
57       L1, L2,
58       ZeqCoupled[2*Pi*f, 100, cc2], 5], {f, 200, 400000},
59     PlotRange -> All,
60     AxesLabel -> {Style["Frequency (Hz)", FontSize -> 14],
61       Style["Power (Watts)", FontSize -> 14]},
62     PlotLabel ->
63       Style[StringForm[
64         "Log-Log plot of Power delivered to circuit when \
65         C='1',L1='2',L2='3',C2='4'", cc, L1, L2, cc2], FontSize
66         -> 18]], {cc,
67         0.00010, 0.5}, {L1, 3.5*10^-3, 0}, {L2, 3.5*10^-3, 0},
68         {cc2, 0.0001,
69         0.5}]
70 Manipulate[
71   LogLogPlot[
72     PowerReceiverApparent[10, 2*Pi*f, cc, 0.5*(L1*L2)^0.5,
73       L1, L2,
74       ZeqCoupled[2*Pi*f, 100, cc2], 5]*
75       Cos[ZeqCoupledArg[2*Pi*f, 100, cc2, L2]], {f, 200,
76         400000},
77     PlotRange -> All,
78     AxesLabel -> {Style["Frequency (Hz)", FontSize -> 14],
79       Style["Power (Watts)", FontSize -> 14]},
80     PlotLabel ->
81       Style[StringForm[
82         "Log-Log plot of Power delivered to circuit when \
83         C='1',L1='2',L2='3',C2='4'", cc, L1, L2, cc2], FontSize
84         -> 18]], {cc,

```

```

79 0.00010, 0.5}, {L1, 3.5*10^-3, 0}, {L2, 3.5*10^-3, 0},
    {cc2, 0.0001,
80 0.5}]

```

## References

- [1] Anderson, Leland I., “Nikola Tesla On His Work With Alternating Currents and Their Application to Wireless Telegraphy, Telephony, and Transmission of Power,” 21st Century Books, 2002.
- [2] Aoki, T. , Dayan, B. , Wilcut, E. , Bowen, W. P., Parkins, A. S., Kippenberg, T. J., Vahala, K. J., and Kimble, H. J., “Observation of strong coupling between one atom and a monolithic microresonator,” *Nature*, Volume 43, 12 October 2006.
- [3] Bansal, D., Vaish, S. K., and Singh, A., “Minor Project Report on Wireless Power Transmission,” Bajaj Institute of Technology and Management, Department of Electronics and Communication Engineering, October 2009.
- [4] Chemandy Electronics Ltd, “Calculator for Skin Effect Depth,” 9 March 2013, <http://chemandy.com/calculators/skin-effect-calculator.htm>.
- [5] Dengler, Richard, “Self inductance of a wire loop as a curve integral,” arXiv:1204.1486, (2012).
- [6] Doherty, P., “Force Between Magnets” Exploratorium 8 July 2003. <http://isaac.exploratorium.edu/~pauld/activities/magnetism/forcebetweenmagnets.html>
- [7] Kurs, André., Karalis, A., Moffat, R., Joannopoulos, J.D., Fischer, P. , Soljacic, M., “Wireless Power Transfer via Strongly Coupled Magnetic Resonances” *Science Magazine*, Volume 317 6 July 2007.
- [8] Kurs, André, “Power Transfer Through Strongly Coupled Resonances”, Master thesis, Master of Science in Physics, Massachusetts Institute of Technology, September 2007.
- [9] Markoff, John, “Intel Moves to Free Gadgets of Their Recharging Cords,” *New York Times*, 21 August 2008, [http://www.nytimes.com/2008/08/21/technology/21intel.html?\\_r=3&ref=technology&oref=slogin&oref=slogin&](http://www.nytimes.com/2008/08/21/technology/21intel.html?_r=3&ref=technology&oref=slogin&oref=slogin&).
- [10] Moffatt, Robert Alexander, “Wireless Transfer of Electric Power,” Senior Exercise, Bachelor of Science in Physics, Massachusetts Institute of Technology, June 2009.
- [11] Office for Resource Efficiency (ORE), “Wall Warts,” Gunnison, CO, 19 October 2012, <http://www.resourceefficiency.org/wall-warts>.
- [12] Pendry, J. B., “A Chiral Route to Negative Refraction”, *Science* Vol. 306 no. 5700 pp. 1353-1355, 19 November 2004
- [13] Raiman, Jonathan, “Wireless Power Transmission,” 2011, <http://www.youtube.com/watch?v=jfNC3qaxoqY>.
- [14] Seifer, Marc J., “Wizard: The Life and Times of Nikola Tesla,” Citadel Press, 1998.
- [15] Tesla, Nikola, U.S. patent, 1,119,732, 1914.
- [16] Tesla, Nikola, “Experiments with Alternating Currents of Very High Frequency and Their Application to Methods of Artificial Illumination,” *AIEE*, Columbia College, N.Y., 20 May 1891.
- [17] Vassilatos, Gerry, “Borderland Visionaries, Radio & Communications Research, Tesla Technology,” *Journal of Borderland Research* - Vol. 52, No. 02, 1996.
- [18] Waters, Benjamin H., Sample, Alanson P., and Smith, Joshua R., “Adaptive Impedance Matching for Magnetically Coupled Resonators”, *PIERS Proceedings*, Moscow, Russia, August 19-23, 2012.
- [19] Witricity Corporation, “Witricity Corp. – About the Company,” 24 April 2013, <http://www.witricity.com/pages/company.html>.
- [20] Yates, Alan, “About Wireless Power Transfer,” Alan Yates’ Laboratory, 24 April 2013, [http://www.youtube.com/watch?v=r1UT4NuygmQ&list=PL8E2158CC794021DB&index=2&feature=plpp\\_video](http://www.youtube.com/watch?v=r1UT4NuygmQ&list=PL8E2158CC794021DB&index=2&feature=plpp_video) and <http://www.vk2zay.net>.