

MG996R High Torque Metal Gear Dual Ball Bearing Servo

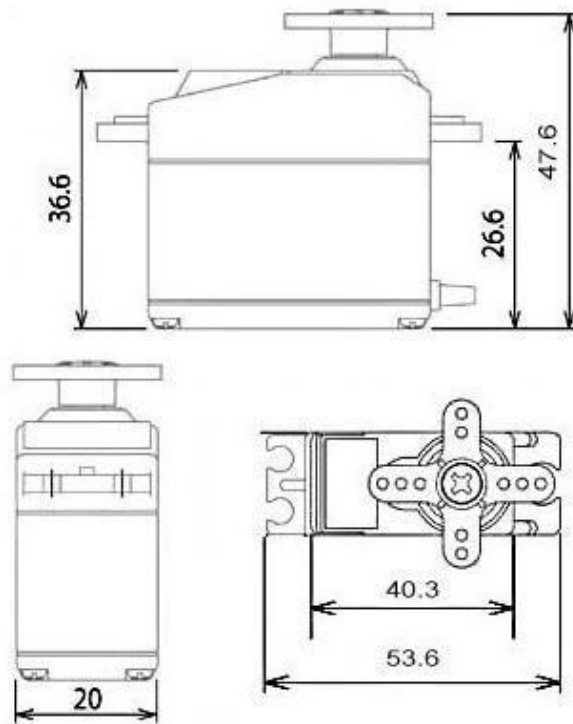

This High-Torque MG996R Digital Servo features metal gearing resulting in extra high 10kg stalling torque in a tiny package. The MG996R is essentially an upgraded version of the famous MG995 servo, and features upgraded shock-proofing and a redesigned PCB and IC control system that make it much more accurate than its predecessor. The gearing and motor have also been upgraded to improve dead bandwith and centering. The unit comes complete with 30cm wire and 3 pin 'S' type female header connector that fits most receivers, including Futaba, JR, GWS, Cirrus, Blue Bird, Blue Arrow, Corona, Berg, Spektrum and Hitec.

This high-torque standard servo can rotate approximately 120 degrees (60 in each direction). You can use any servo code, hardware or library to control these servos, so it's great for beginners who want to make stuff move without building a motor controller with feedback & gear box, especially since it will fit in small places. The MG996R Metal Gear Servo also comes with a selection of arms and hardware to get you set up nice and fast!

Specifications

- Weight: 55 g
- Dimension: 40.7 x 19.7 x 42.9 mm approx.
- Stall torque: 9.4 kgf·cm (4.8 V), 11 kgf·cm (6 V)
- Operating speed: 0.17 s/60° (4.8 V), 0.14 s/60° (6 V)

- ❑ Operating voltage: 4.8 V a 7.2 V
- ❑ Running Current 500 mA – 900 mA (6V)
- ❑ Stall Current 2.5 A (6V)
- ❑ Dead band width: 5 μ s
- ❑ Stable and shock proof double ball bearing design
- ❑ Temperature range: 0 °C – 55 °C

