

NO.2 TOL ± 0.2

$\sqrt{N7}$ DRILL

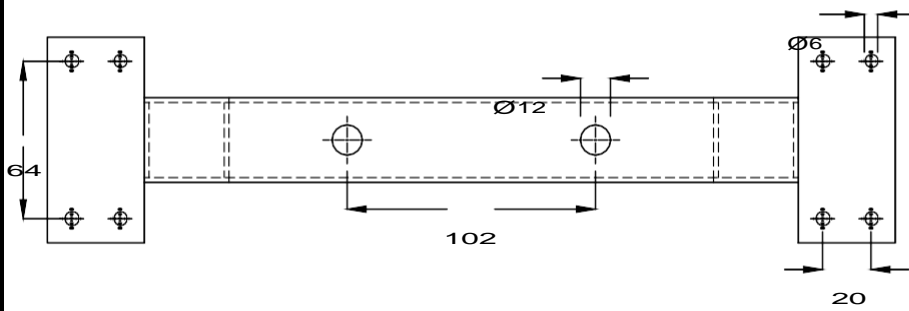
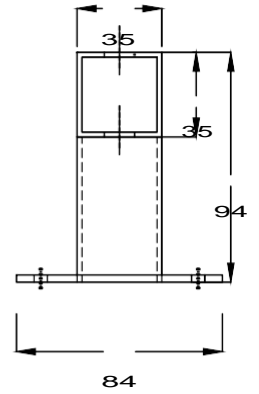
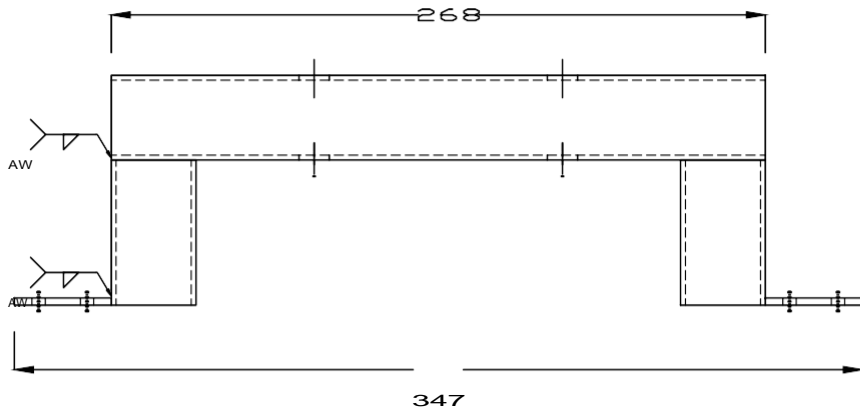

| Jumlah | Nama Bagian | No. Bag | Bahan | Ukuran | Keterangan |
|--------|---|---------|--------------|------------------------------|---------------------------|
| 1 | Dudukan Roda Gigi Bawah | 2 | Besi Persegi | 35 x 35 x 2 | Dibuat |
| III | Perubahan | | | | |
| | DUDUKAN RODA GIGI BAWAH | | | Skala 1 : 5 | Digambar RESKY. A.L |
| | Jurusan Teknik Mesin Politeknik Negeri Sriwijaya | | | Diperiksa GMF/2018/02 | |

NO.3 TOL ± 0.2

N7 DRILL

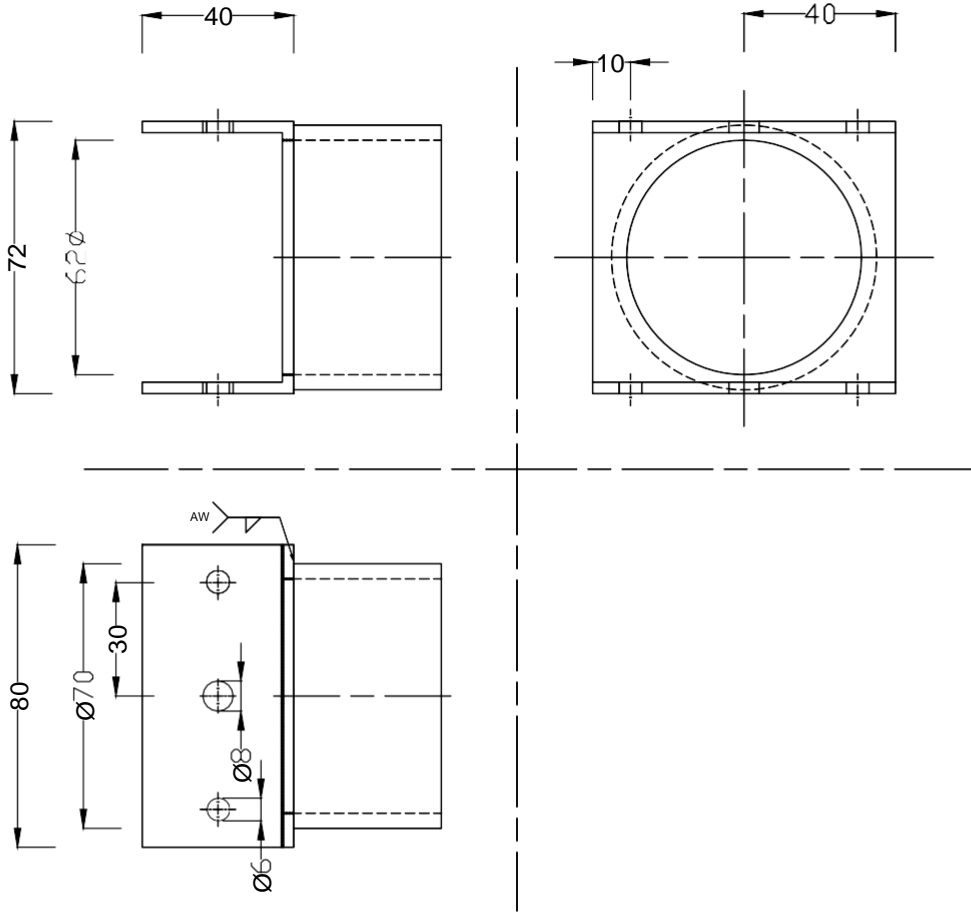

| | | | | | | | | |
|---|-----------|--------------------|-------------------------------|----------------|-------------------|-----------------------|-------------------|----------------|
| | | 1 | Ragum Mata Potong dan Bearing | 3 | Profil U dan Pipa | 80 x 80 x 78 | Dibuat | |
| Jumlah | | Nama Bagian | | No. Bag | Bahan | Ukuran | Keterangan | |
| III | II | I | Perubahan | | | | | |
| RAGUM MATA POTONG DAN BEARING | | | | | | Skala 1 : 2 | Digambar | RESKY. A. L |
| | | | | | | | Diperiksa | |
| Jurusan Teknik Mesin Politeknik Negeri Sriwijaya | | | | | | GMF/2018/03 | | |

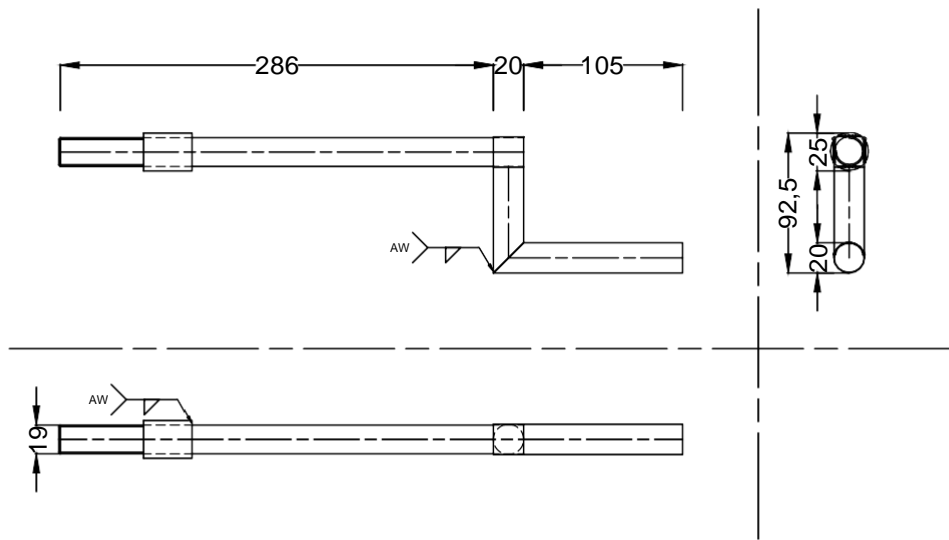

| | | | | | | | | |
|---|----|---|--------------------|----------------|---------------|------------------------------|-------------------|----------------|
| | | 1 | Pedal Roda Gigi | 4 | Pipa Galvanis | 392 x 88 x 19 | Dibuat | |
| Jumlah | | | Nama Bagian | No. Bag | Bahan | Ukuran | Keterangan | |
| III | II | I | Perubahan | | | | | |
| PEDAL RODA GIGI | | | | | | Skala 1 : 5 | Digambar | RESKY. A. L |
| | | | | | | | Diperiksa | |
| Jurusan Teknik Mesin Politeknik Negeri Sriwijaya | | | | | | GMF/2018/04 | | |

NO.5 TOL ± 0.2 $\sqrt{N7}$ DRILL

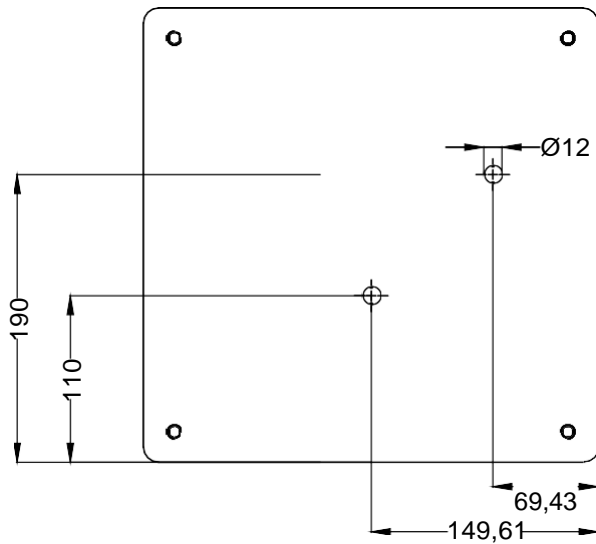
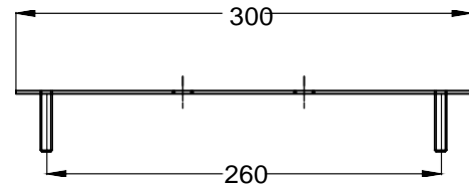
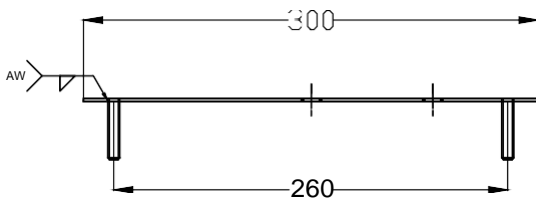

| | | | | | | | | |
|---|-----------|----------|--------------------|----------------|--------------|------------------------------|-------------------|----------------|
| | | 1 | Plat Pelapis Meja | 5 | Plat Besi | 300 x 300 x 2 | Dibuat | |
| Jumlah | | | Nama Bagian | No. Bag | Bahan | Ukuran | Keterangan | |
| III | II | I | Perubahan | | | | | |
| PLAT PELAPIS MEJA BENGKOK | | | | | | Skala 1 : 5 | Digambar | RESKY. A. L |
| | | | | | | | Diperiksa | |
| Jurusan Teknik Mesin Politeknik Negeri Sriwijaya | | | | | | GMF/2018/05 | | |

NO.6 TOL ± 0.2 N7 DRILL

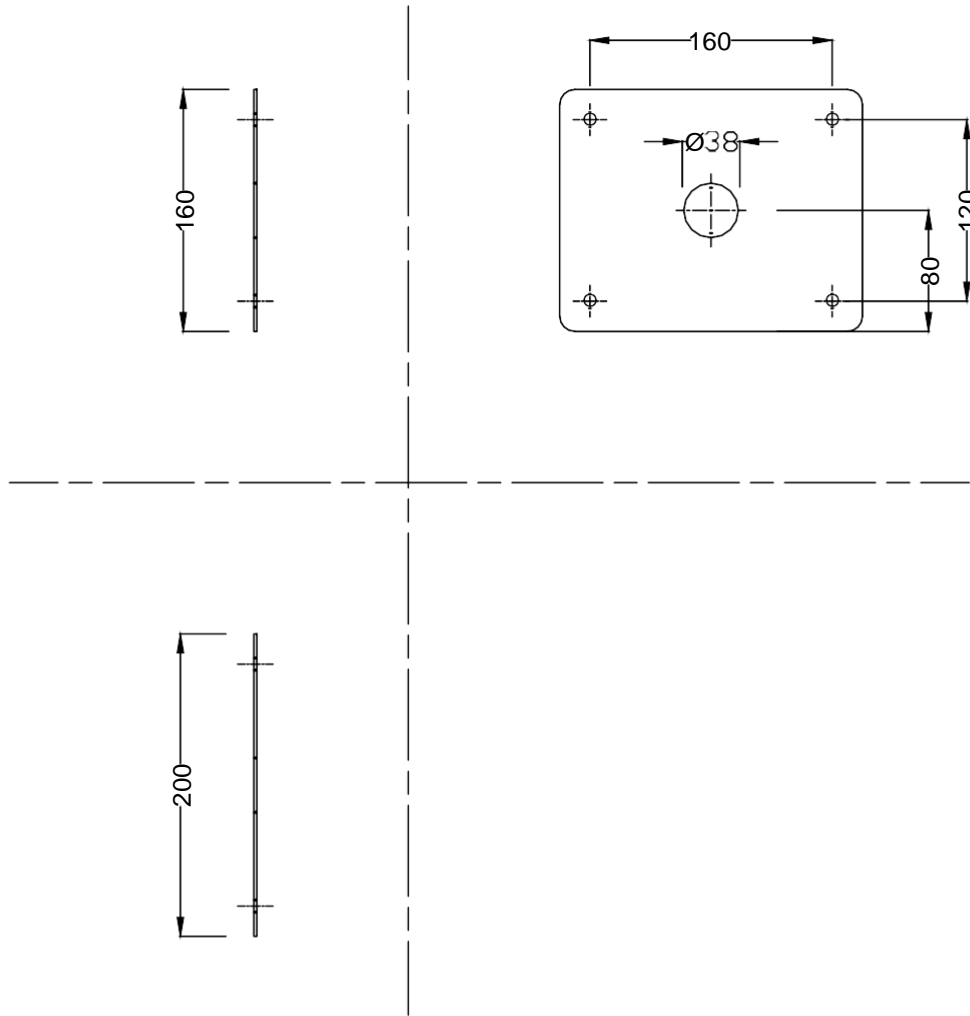

| | | | | | | | | |
|---|----|---|----------------------------|----------------|--------------|-----------------------|-------------------|----------------|
| | | 1 | Plat Pelapis Meja Pemotong | 6 | Plat Besi | 160 X 200 X 2 | Dibuat | |
| Jumlah | | | Nama Bagian | No. Bag | Bahan | Ukuran | Keterangan | |
| III | II | I | Perubahan | | | | | |
| PLAT PELAPIS MEJA PEMOTONG | | | | | | Skala 1 : 5 | Digambar | RESKY. A. L |
| | | | | | | | Diperiksa | |
| Jurusan Teknik Mesin Politeknik Negeri Sriwijaya | | | | | | GMF/2018/06 | | |

NO.7 TOL ± 0.2 N7 DRILL

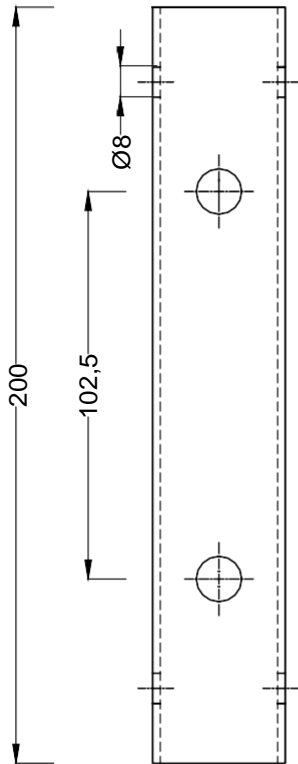
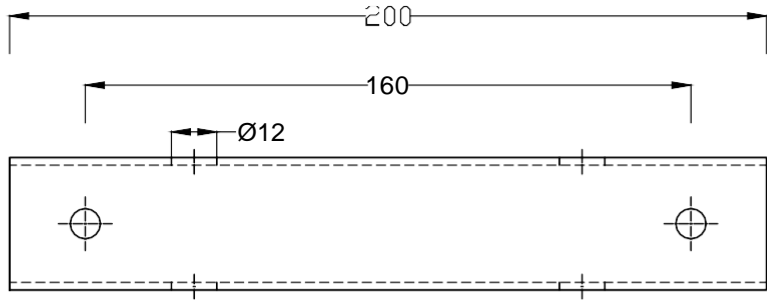
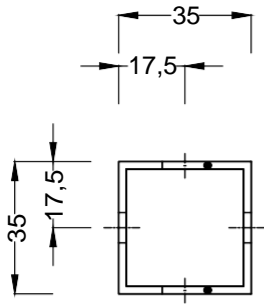

| | | | | | | | | |
|---|----|---|--------------------|----------------|--------------|------------------------------|-------------------|----------------|
| | | 1 | Dudukan Bearing | 7 | Besi Persegi | 35 x 35 x 2 | Dibuat | |
| Jumlah | | | Nama Bagian | No. Bag | Bahan | Ukuran | Keterangan | |
| III | II | I | Perubahan | | | | | |
| DUDUKAN BEARING | | | | | | Skala 1 : 2 | Digambar | RESKY. A. L |
| | | | | | | | Diperiksa | |
| Jurusan Teknik Mesin Politeknik Negeri Sriwijaya | | | | | | GMF/2018/07 | | |

NO.8 TOL ± 0.2

N7 DRILL

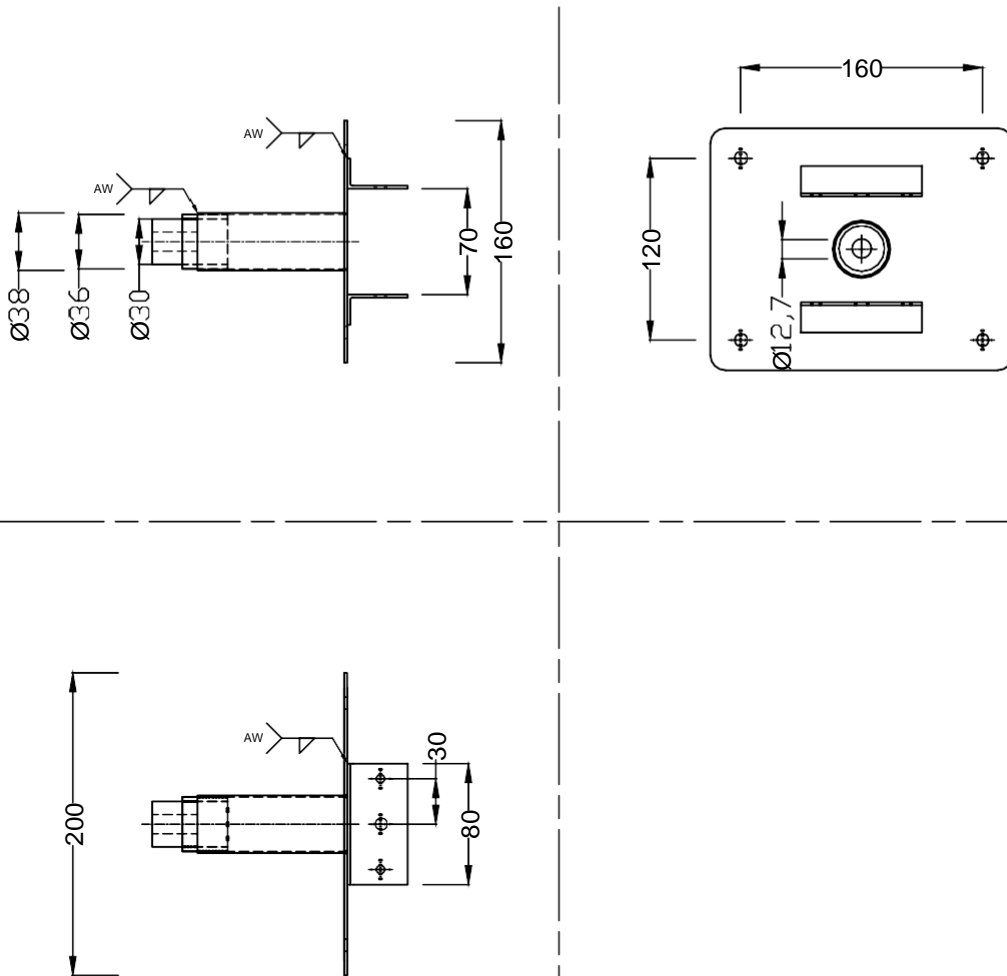

| | | | | | | | | |
|---|-----------|----------|------------------------|----------------|--------------------|------------------------------|---|--|
| | | 1 | Dudukan Roda Gigi Atas | 8 | Plat Besi dan Pipa | 160 x 200 x 150 | Dibuat | |
| Jumlah | | | Nama Bagian | No. Bag | Bahan | Ukuran | Keterangan | |
| III | II | I | Perubahan | | | | | |
| DUDUKAN RODA GIGI ATAS | | | | | | Skala 1 : 5 | Digambar RESKY. A. L Diperiksa | |
| Jurusan Teknik Mesin Politeknik Negeri Sriwijaya | | | | | | GMF/2018/08 | | |

NO.9 TOL ± 0.2

N7 DRILL

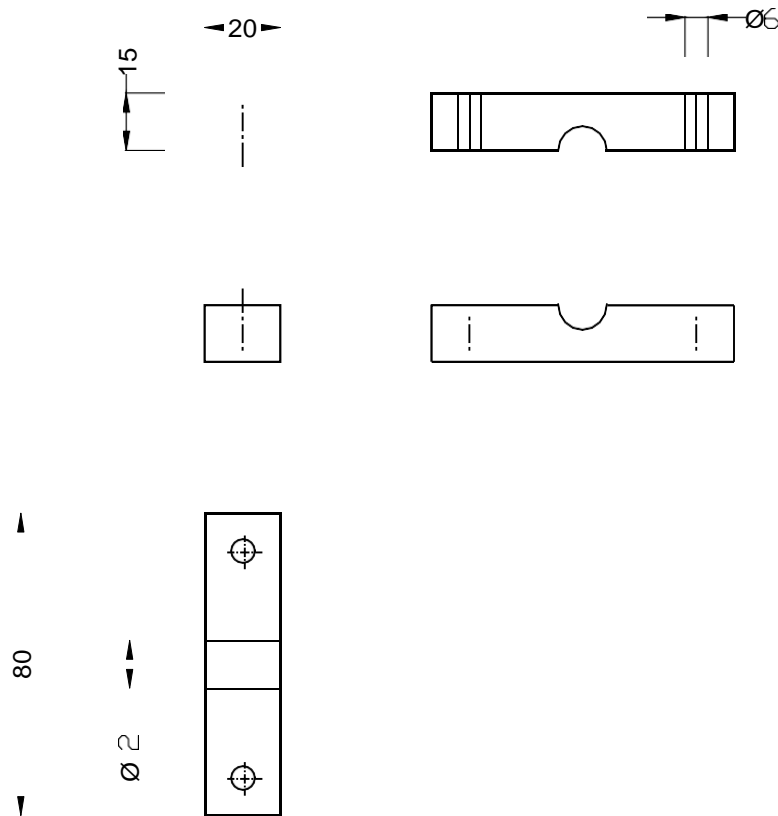

| Jumlah | Nama Bagian | No. Bag | Bahan | Ukuran | Keterangan |
|--------|--------------|---------|-------|--------------|------------|
| 1 | Ragum Tubing | 9 | Besi | 80 x 30 x 20 | Dibuat |
| III | Perubahan | | | | |
| II | | | | | |
| I | | | | | |

RAGUM TUBING

Skala
1 : 2

Digambar
Diperiksa

RESKY.
A. L

DRILL
N7
NO.10 TOL ± 0.2

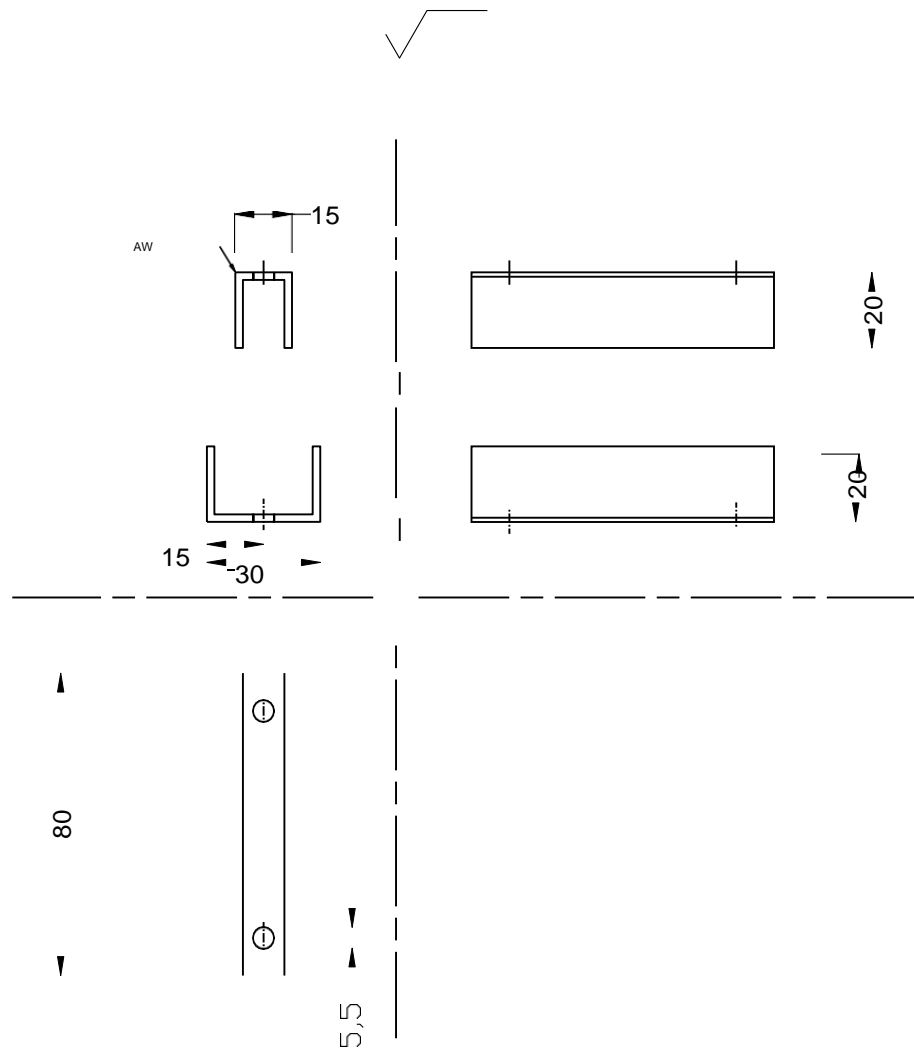

| | | | | | | | | |
|---|-----------|----------|--|----------------|--------------|-----------------------|-------------------|----------------|
| | | 1 | Duduksn Mata Potong dan <i>Bearing</i> | 10 | Plat Besi | 80 x 30 x 20 | Dibuat | |
| Jumlah | | | Nama Bagian | No. Bag | Bahan | Ukuran | Keterangan | |
| III | II | I | Perubahan | | | | _____ | _____ |
| DUDUKAN MATA POTONG DAN BEARING | | | | | | Skala 1 : 2 | Digambar | RESKY. A. L |
| | | | | | | | Diperiksa | |
| Jurusan Teknik Mesin Politeknik Negeri Sriwijaya | | | | | | GMF/2018/10 | | |

NO.11 TOL ± 0.2

N7 DRILL

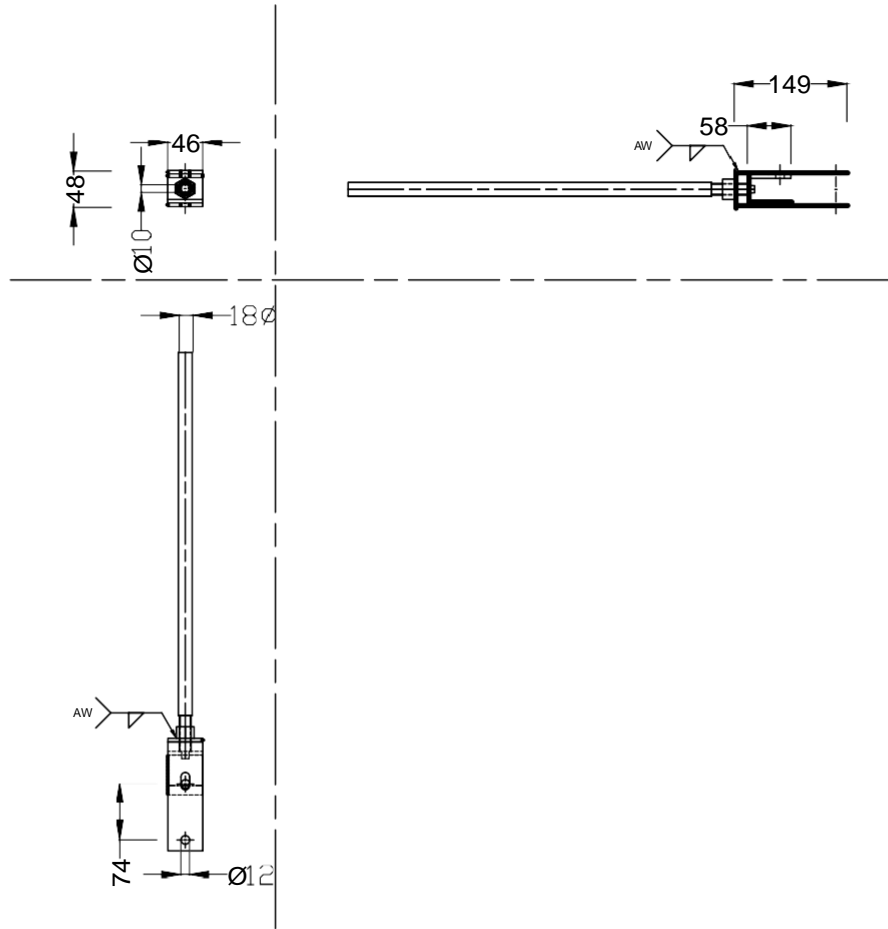

| | | | | | | | | |
|---|----|---|-----------------------|----------------|---------------------|-------------------------------|-------------------|----------------|
| | | 1 | Pedal Role Pembengkok | 11 | Plat Besi dan Poros | 686 x 50 x 48 | Dibuat | |
| Jumlah | | | Nama Bagian | No. Bag | Bahan | Ukuran | Keterangan | |
| III | II | I | Perubahan | | | | | |
| PEDAL ROLE PEMBENGGKOK | | | | | | Skala 1 : 10 | Digambar | RESKY. A. L |
| | | | | | | | Diperiksa | |
| Jurusan Teknik Mesin Politeknik Negeri Sriwijaya | | | | | | GMF/2018/11 | | |

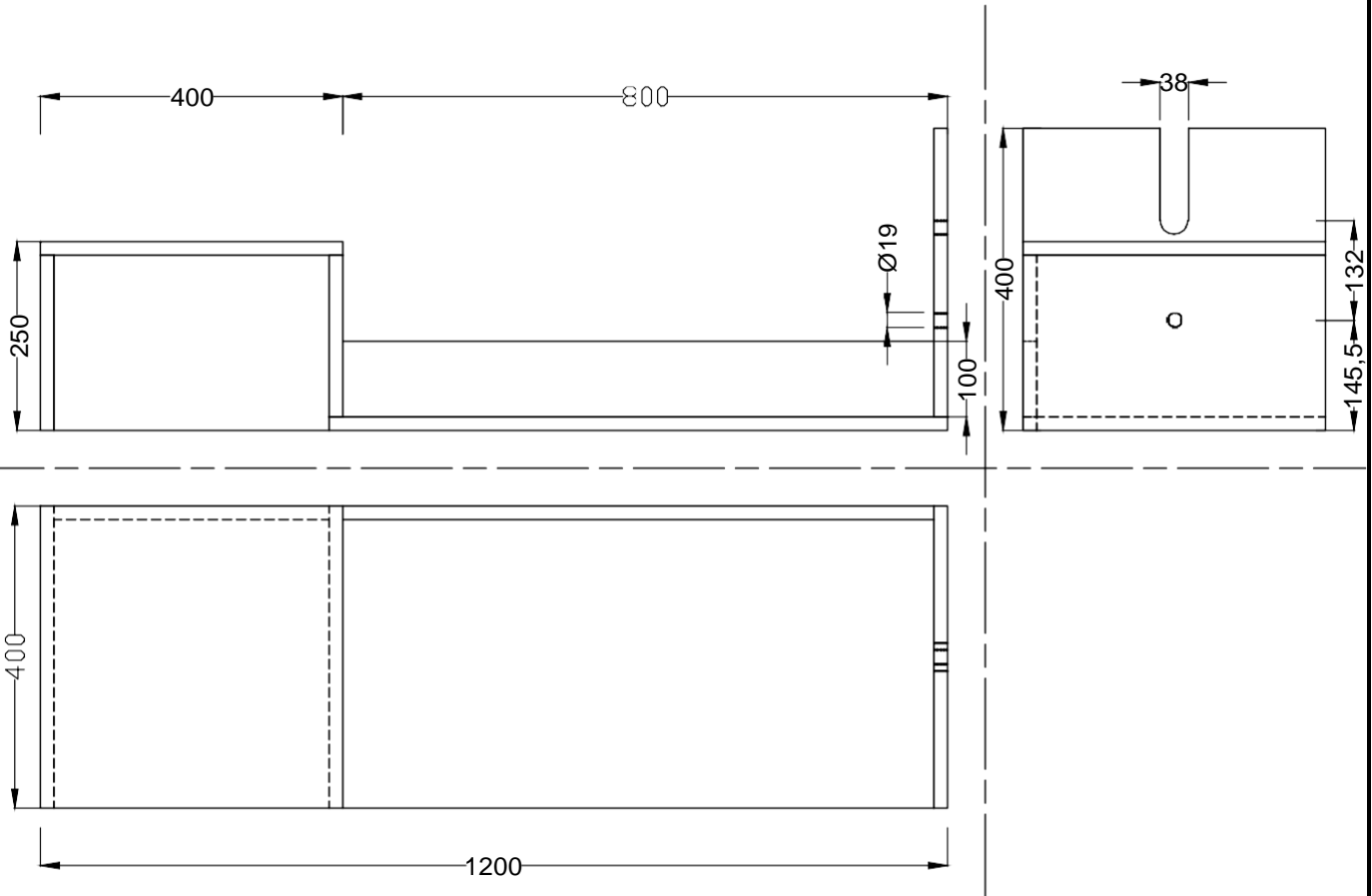

| | | | | | | | | |
|---|----|---|--------------------|----------------|--------------|-------------------------------|----------------------------|--|
| | | 1 | Kerangka Meja | 1 | Plywood | 2440 x 1220 x 18 | Dibuat | |
| Jumlah | | | Nama Bagian | No. Bag | Bahan | Ukuran | Keterangan | |
| III | II | I | Perubahan | | | | | |
| KERANGKA MEJA | | | | | | Skala 1 : 10 | Digambar RESKY. A. L | |
| | | | | | | Diperiksa | | |
| Jurusan Teknik Mesin Politeknik Negeri Sriwijaya | | | | | | GMF/2018/01 | | |