

		1	ACU	10	Various	12 Volt	Dibeli		
		1	Bosch	9	ST. 42	25x100	Dibuat		
		1	Generator	8	Various	24Dc	Dibeli		
		1	Roda Gigi 2	7	Steel	12x4	Dibeli		
		1	Roda Gigi 1	6	Steel	3x5	Dibeli		
		1	Shaft	5	ST. 42	18x20	Dibeli		
		3	Bearing	4	Steel	No. 6301	Dibeli		
		1	Main Shaft	3	ST. 42	10x1000	Dibeli		
		1	Sudu Putar	2	Various	600x700	Dibuat		
		1	Frame	1	Fe 410	630X630X1000	Dibuat		
		Jumlah	Nama Bagian	Nomor Bagian	Bahan	Ukuran	Keterangan		
III	II	I	Perubahan :						
<p style="text-align: center;"><b>Prototipe Turbin Angin</b></p>						Skala	Digambar	5/5/2018	Team
						1:10	Diperiksa		
<p style="text-align: center;">Politenik Negeri Sriwijaya          jl. Srijaya Negara Bukit Besar Palembang          website: www.polsri.net</p>						DRAME SW ASSEMBLY NO.01/2018			

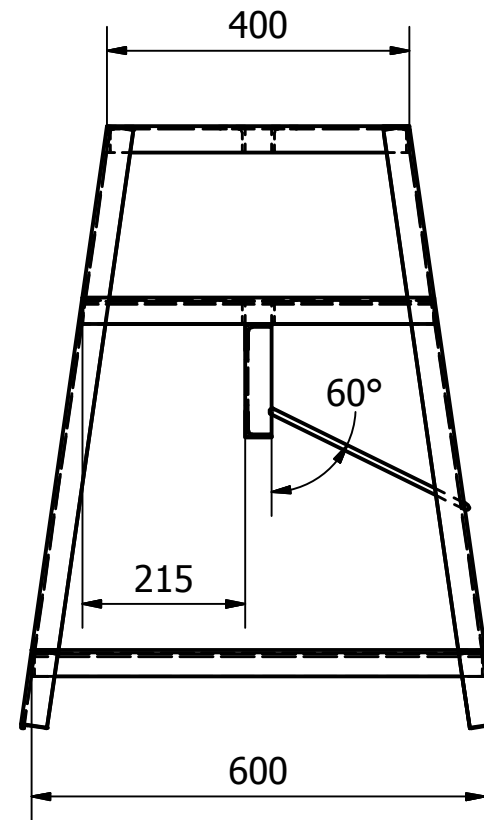

D (1 : 5)

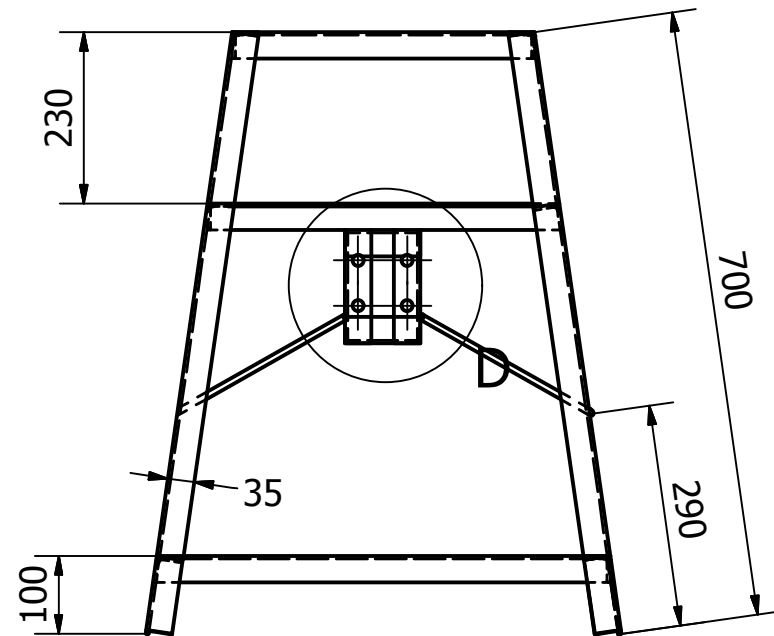
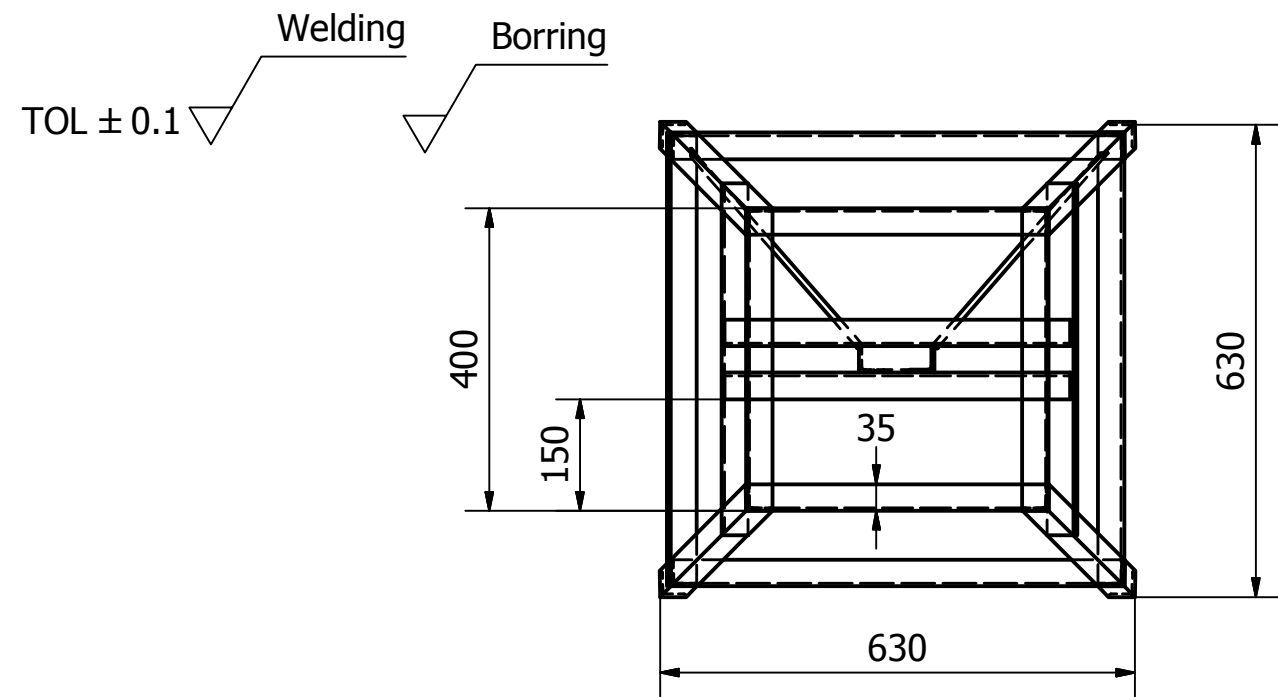
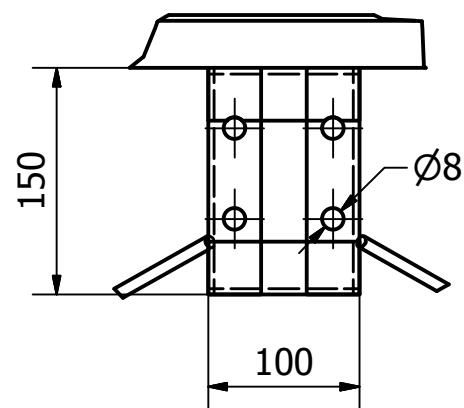

Jumlah	Nama Bagian	Nomor Bagian	Bahan	Ukuran	Keterangan		
1	Frame	1	Fe 360	360x360x700	Dibuat		
III	II	I	Perubahan :				
Prototipe Turbin Angin				Skala	Digambar	5/5/2018	Team
				1 : 10	Diperiksa		
Politenik Negeri Sriwijaya jl. Sriwijaya Negara Bukit Besar Palembang website: www.polsri.net				DRAME SW PART NO.01/2018			

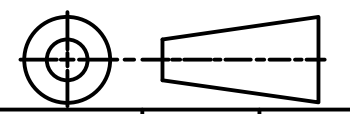

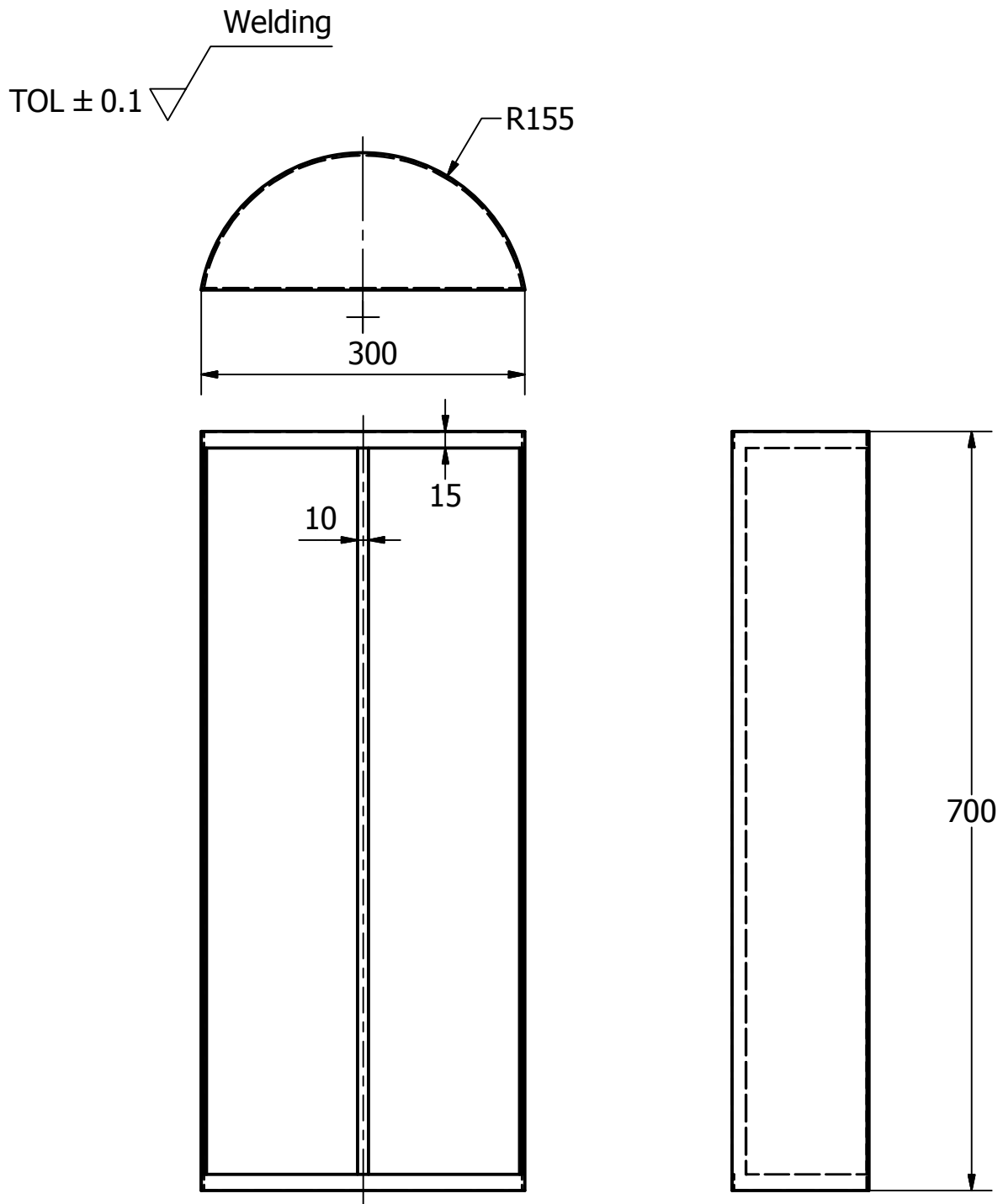

		2	Kerangka Sudu	2	Fe 410	300x700	Dibuat		
Jumlah		Nama Bagian		Nomor Bagian	Bahan	Ukuran	Keterangan		
III	II	I	Perubahan :						
Prototipe Turbin Angin						Skala	Digambar	5/5/2018	Team
						1 : 5	Diperiksa		
Politenik Negeri Sriwijaya jl. Srijaya Negara Bukit Besar Palembang website: www.polsri.net						DRAME SW PART NO.02/2018			

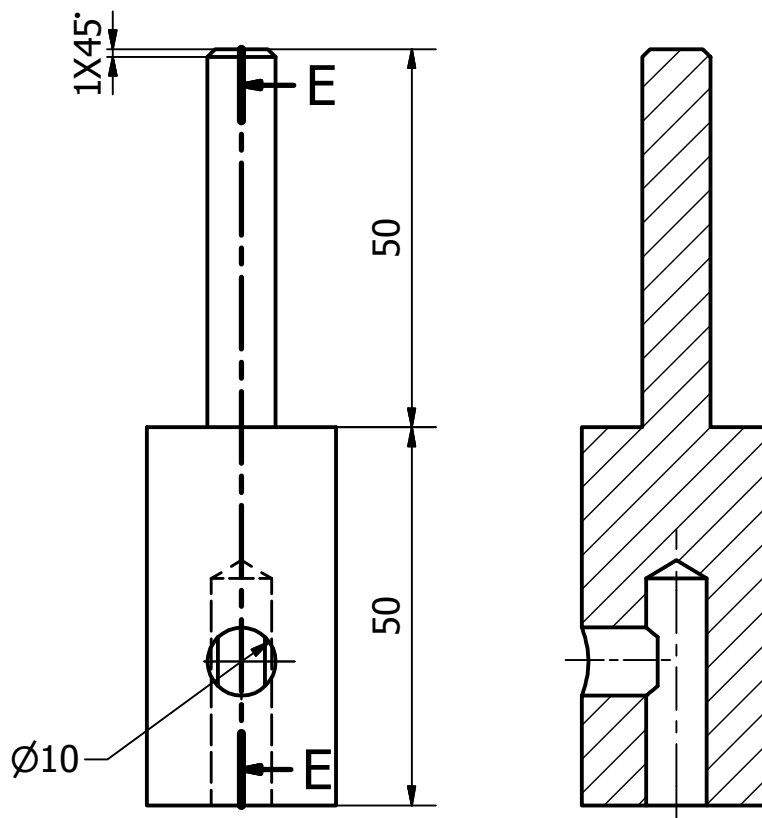
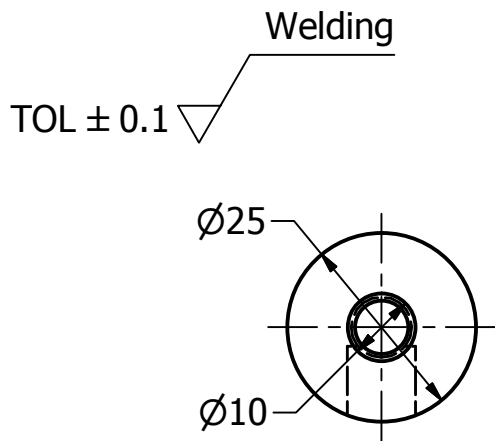

		1	Bosch	9	ST. 37	25x100	Dibuat		
Jumlah		Nama Bagian		Nomor Bagian	Bahan	Ukuran	Keterangan		
III	II	I	Perubahan :						
Prototipe Turbin Angin						Skala	Digambar	5/5/2018	Team
						1 : 1	Diperiksa		
Politenik Negeri Sriwijaya jl. Srijaya Negara Bukit Besar Palembang website: www.polsri.net						DRAME SW PART NO.3/2018			

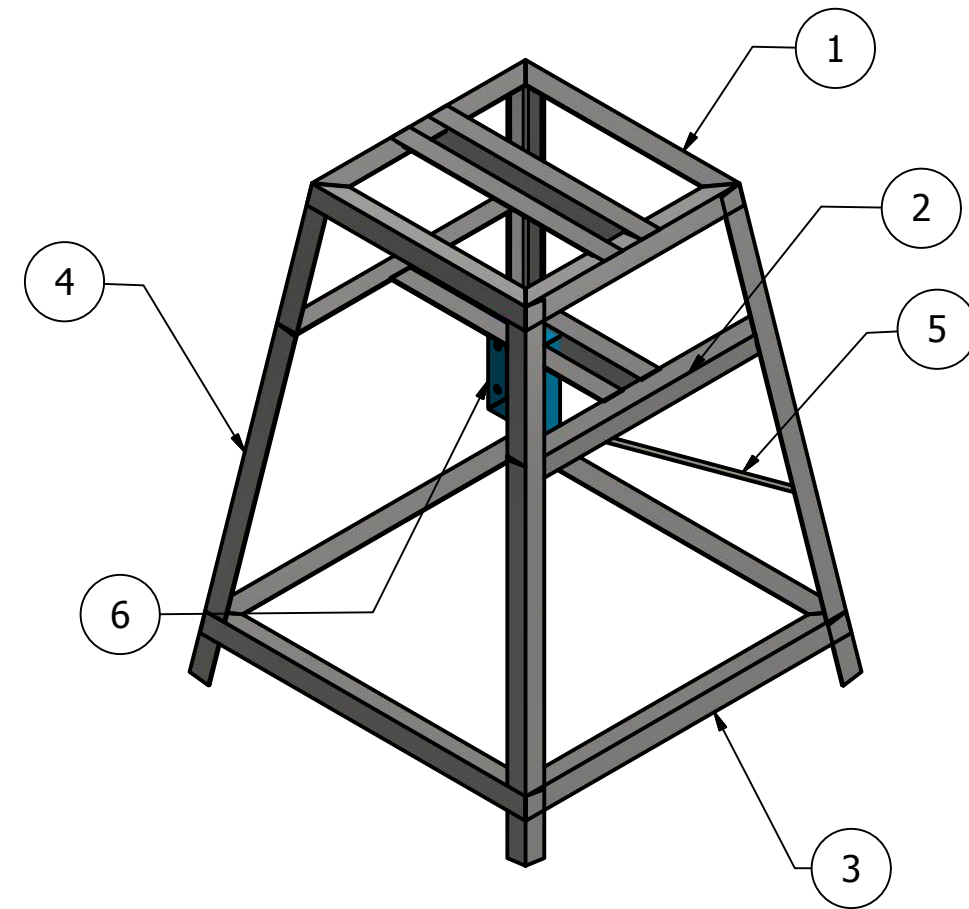
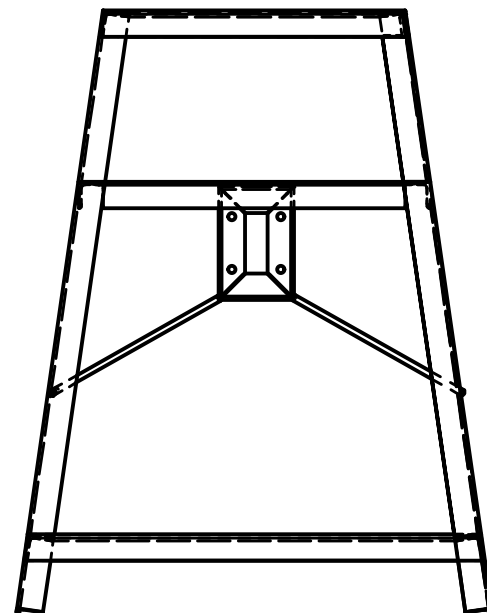
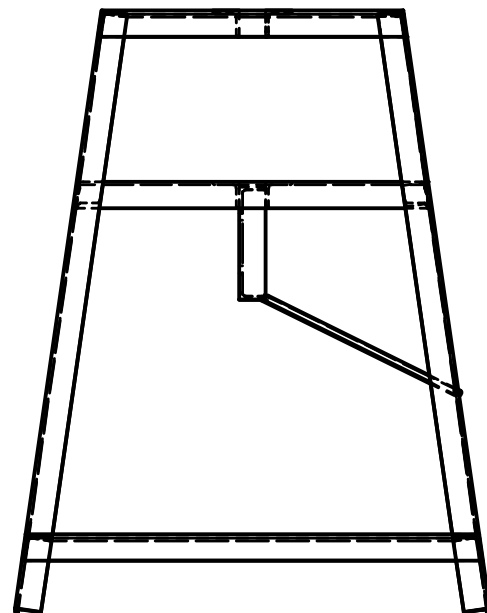
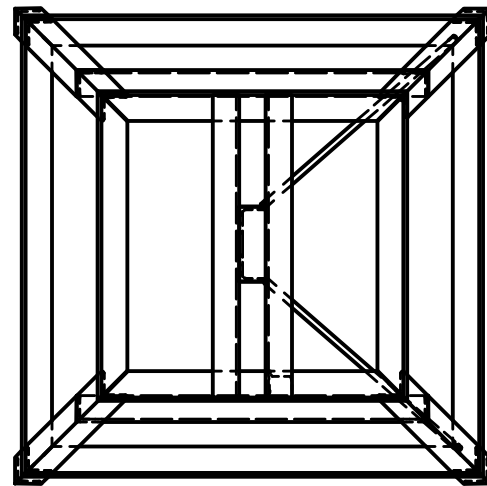

		1	DUDUKAN GENERATOR	6	ST. 42	L 35X35X3	DIBUAT
		2	PENYANGGA DUDUKAN	5	ST. 42	8X180	DIBUAT
		4	KAKI RANGKA	4	ST. 42	L 35X35X3	DIBUAT
		1	KERANGKA BAWAH	3	ST. 42	L 35X35X3	DIBUAT
		1	KERANGKA TENGAH	2	ST. 42	L 35X35X3	DIBUAT
		1	KERANGKA ATAS	1	ST. 42	L 35X35X3	DIBUAT
Jumlah	Nama Bagian	Nomor Bagian	Bahan	Ukuran	Keterangan		

III	II	I	Perubahan :							
			<p style="text-align: center;"><b>PROTOTIPE TURBIN ANGIN</b></p> <p style="text-align: center;">Politenik Negeri Sriwijaya jl. Srijaya Negara Bukit Besar Palembang website: www.polsri.net</p>				Skala	Digambar	7/7/2018	Team
							1:10	Diperiksa		
						DRAME SW INV ASSEMBLY 02/2018				

TOL ± 0.1

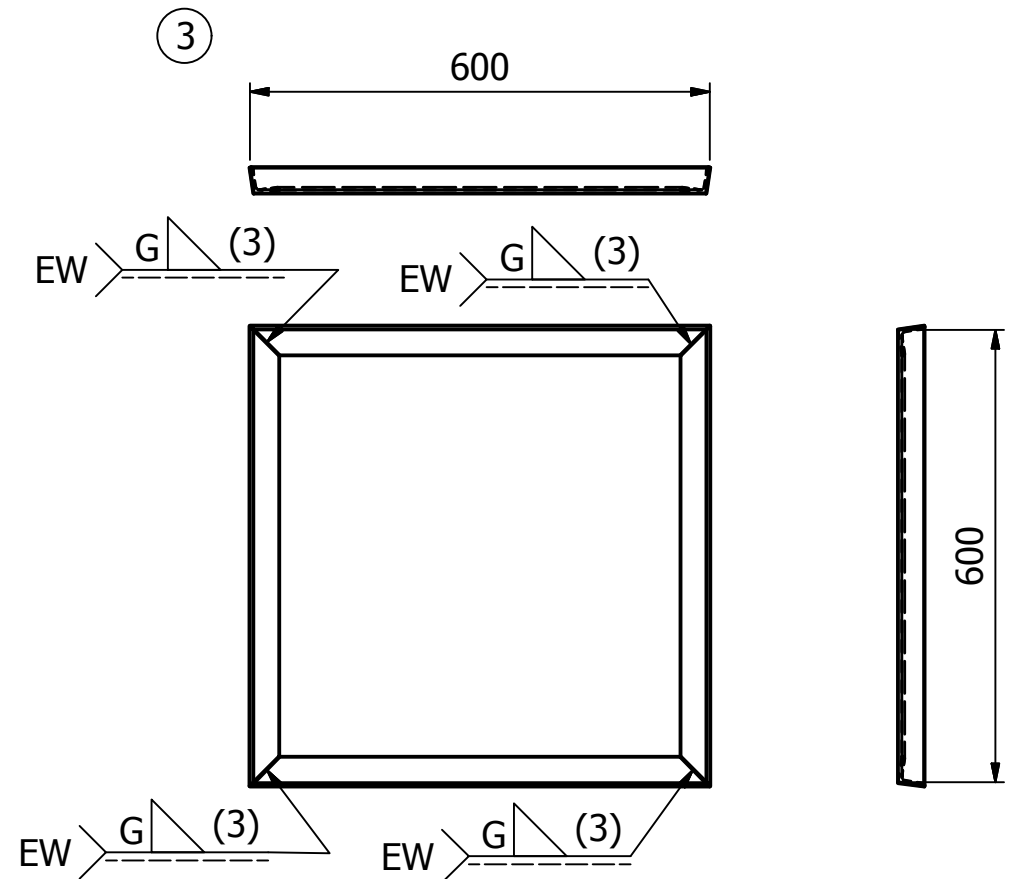
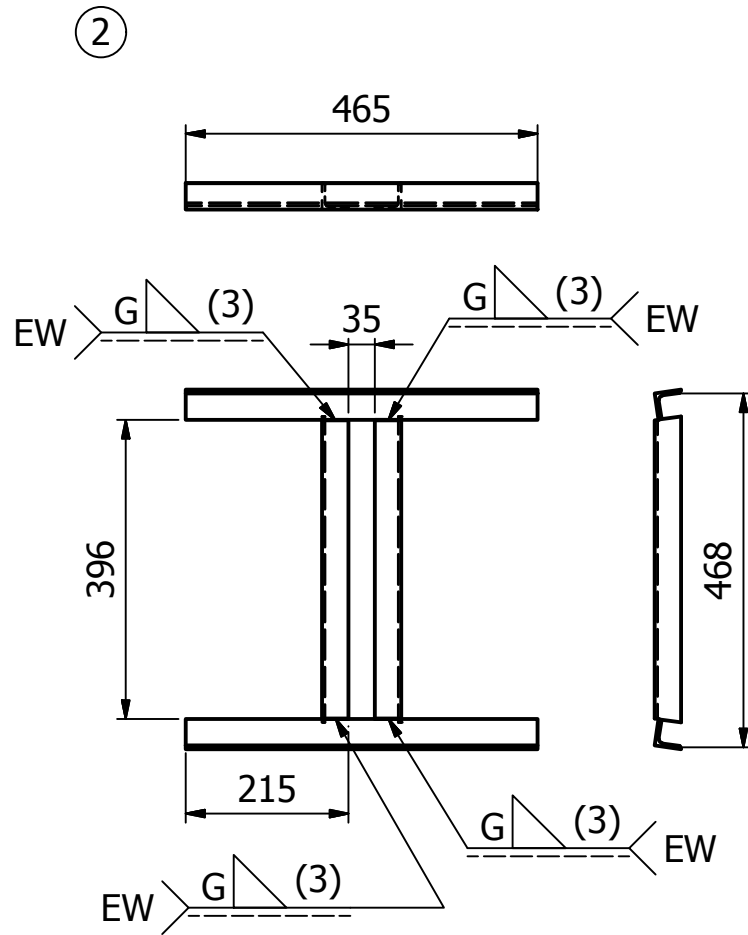
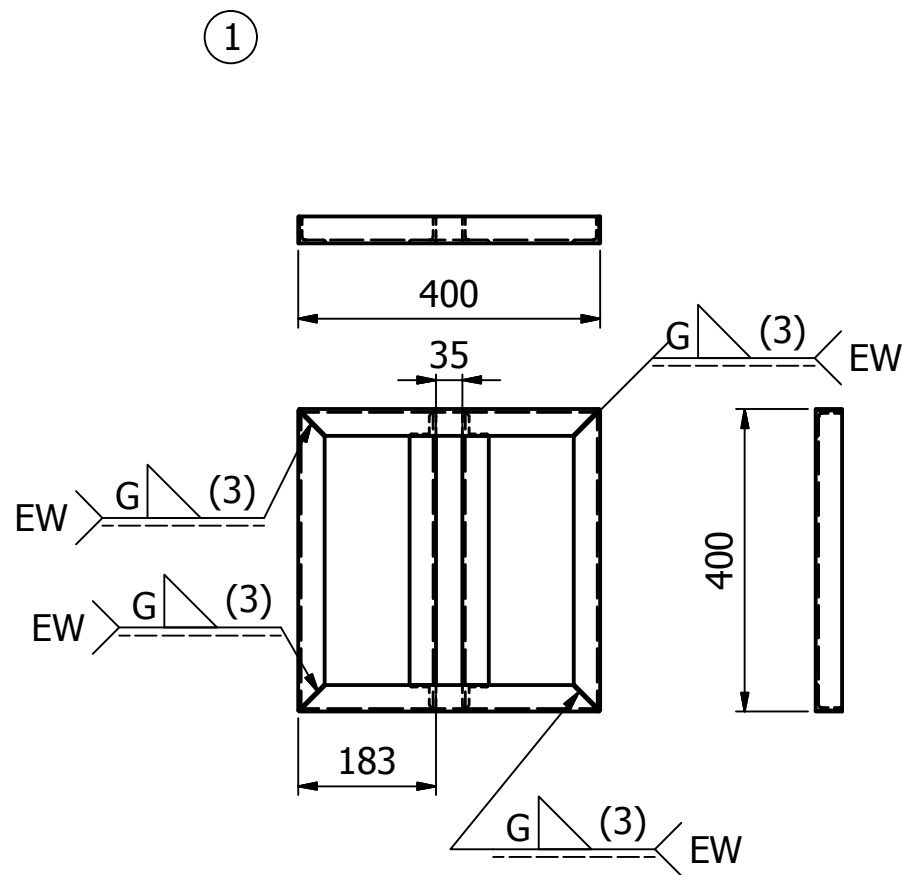

		1	KERANGKA BAWAH	3	ST. 42	L 35X35X3	DIBUAT		
		1	KERANGKA TENGAH	2	ST. 42	L 35X35X3	DIBUAT		
		1	KERANGKA ATAS	1	ST. 42	L 35X35X3	DIBUAT		
Jumlah			Nama Bagian	Nomor Bagian	Bahan	Ukuran	Keterangan		
III	II	I	Perubahan :						
<p style="text-align: center;"><b>PROTOTIPE TURBIN ANGIN</b></p>						Skala	Digambar	7/7/2018	Team
						1:10	Diperiksa		
Politenik Negeri Sriwijaya jl. Srijaya Negara Bukit Besar Palembang website: www.polsri.net						DRAME INV PART 01/2018			

TOL ± 0.1

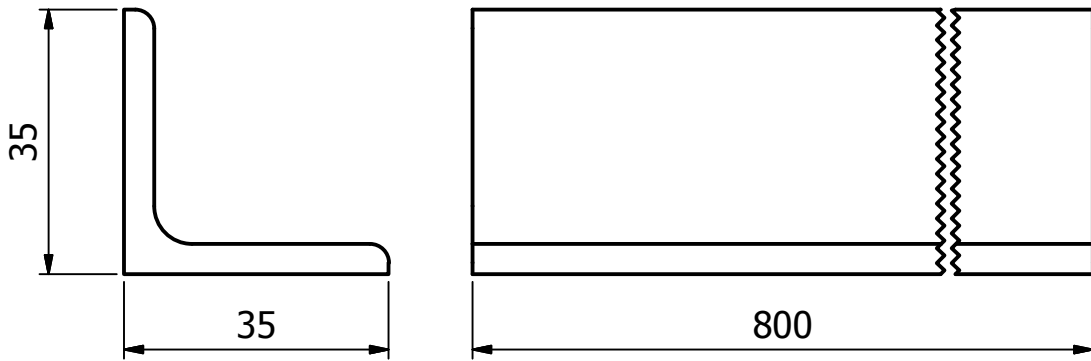

		4	KAKI KERANGKA	4	ST. 42	L 35X35X3	DIBUAT				
Jumlah			Nama Bagian	Nomor Bagian	Bahan	Ukuran	Keterangan				
III	II	I	Perubahan :								
			PROTOTIPE TURBIN ANGIN				Skala	Digambar	7/7/2018	Team	
							1:1	Diperiksa			
Politenik Negeri Sriwijaya jl. Srijaya Negara Bukit Besar Palembang website: www.polsri.net						DRAME INV PART NO.02					

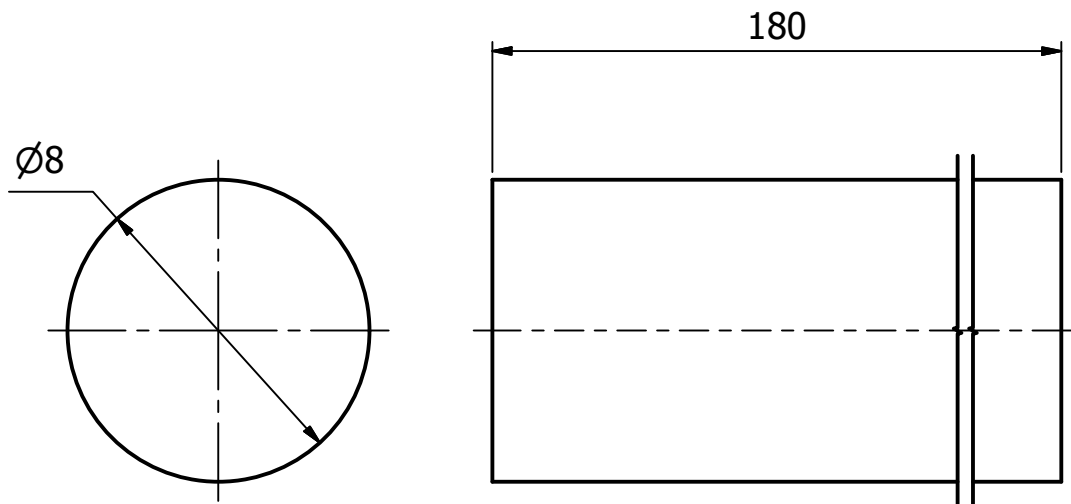

		2	PENYANGGA DUDUKAN	5	ST. 42	L 35X35X3	DIBUAT			
Jumlah		Nama Bagian		Nomor Bagian	Bahan	Ukuran	Keterangan			
III	II	I	Perubahan :							
			PROTOTIPE TURBIN ANGIN				Skala	Digambar	7/7/2018	Team
							5:1	Diperiksa		
Politenik Negeri Sriwijaya jl. Srijaya Negara Bukit Besar Palembang website: www.polsri.net						DRAME INV PART 03/2018				



TOL ± 0.1

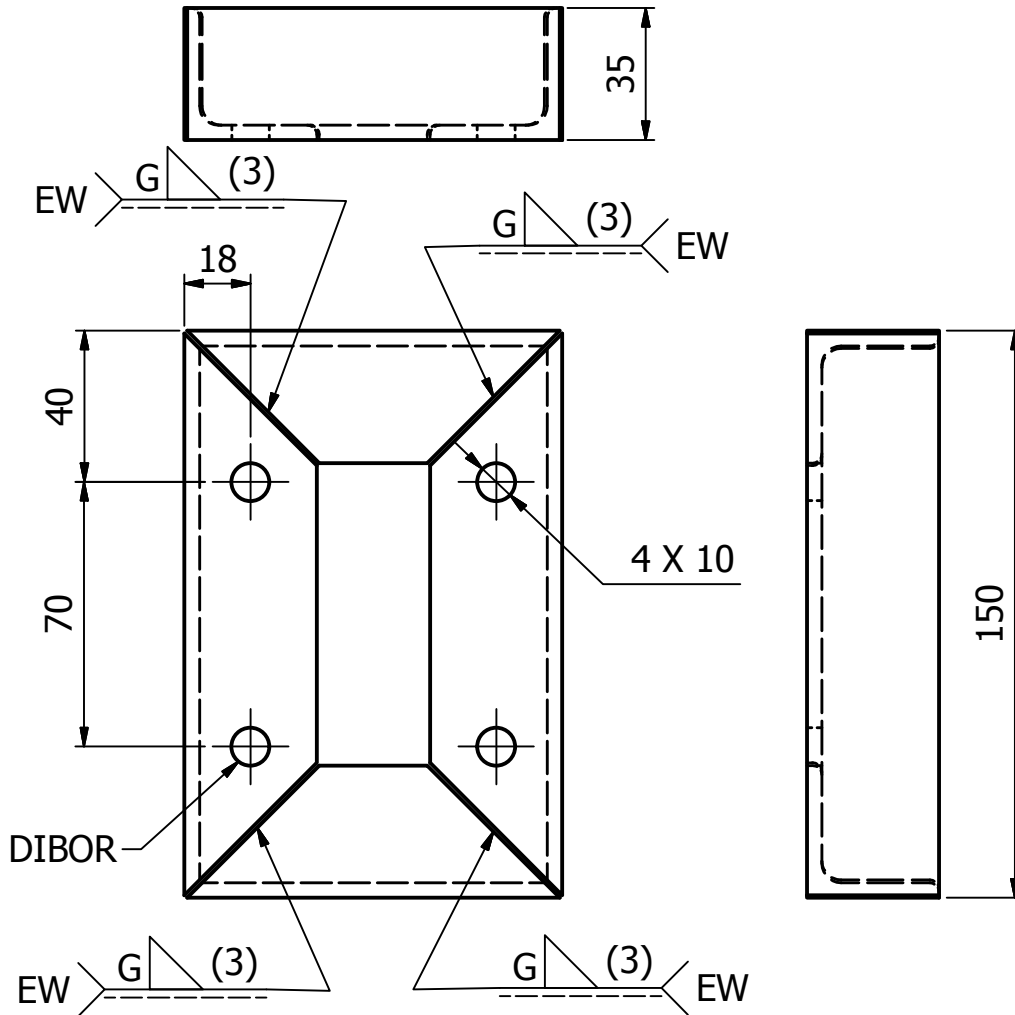

		1	DUDUKAN GENERATOR	6	ST. 42	L 35X35X3	DIBUAT	
Jumlah		Nama Bagian		Nomor Bagian	Bahan	Ukuran	Keterangan	
III	II	I	Perubahan :					
PROTOTYPE TURBIN ANGIN						Skala	Digambar 7/7/2018 Team	
						1:2	Diperiksa	
Politenik Negeri Sriwijaya jl. Srijaya Negara Bukit Besar Palembang website: www.polsri.net						DRAME INV PART NO. 04/2018		