

	1	Meja	12	Baja Karbon	850 x 350 x 700	Dibuat
Jumlah Quantity	Nama Bagian Part Name	No. Bag Part No.	Bahan Material	Ukuran Size	Keterangan Remark	
⊕	⌘	⌘	Perubahan : Revision			
				Skala Scale	Digambar Drawn	TIM
				1:15	Diperiksa Checked	
POLITEKNIK NEGERI SRIWIJAYA Jl. Sriwijaya Negara Bukit Besar Palembang				DRAME.PART NO.12/2018		

TOL. ± 0.1  Drill

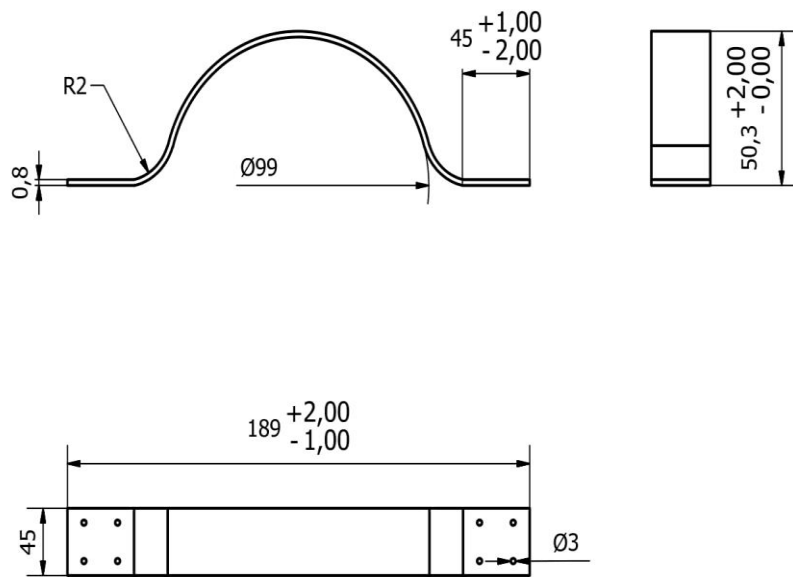

	4	Klem	10	Aluminium	189 x 45 x Ø99	Dibuat	
Jumlah Quantity	Nama Bagian Part Name	No. Bag Part No.	Bahan Material	Ukuran Size	Keterangan Remark		
			Perubahan : Revision				
Klem				Skala Scale	Digambar Drawn	TIM	
				1 : 3	Diperiksa Checked		
POLITEKNIK NEGERI SRIWIJAYA Jl. Srijaya Negara Bukit Besar Palembang				DRAME PART NO.10/2018			

TOL.±1 ∇ N7 DRILL

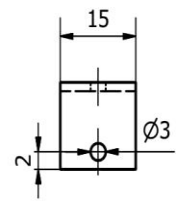
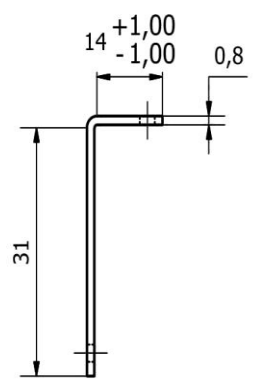
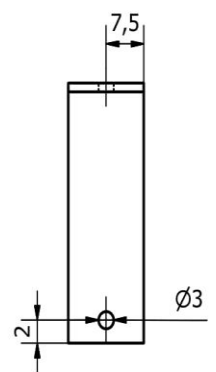

	6	Penyangga Hub	4	Aluminium	31 x 14	Dibuat
Jumlah Quantity		Nama Bagian Part Name	No. Bag Part No.	Bahan Material	Ukuran Size	Keterangan Remark
⊕	⋈	Perubahan : Revision				
		Penyangga Hub			Skala Scale 1 : 1	Digambar Drawn Diperiksa Checked TIM
POLITEKNIK NEGERI SRIWIJAYA Jl. Srijaya Negara Bukit Besar Palembang					DRAME.PART NO.4/2018	

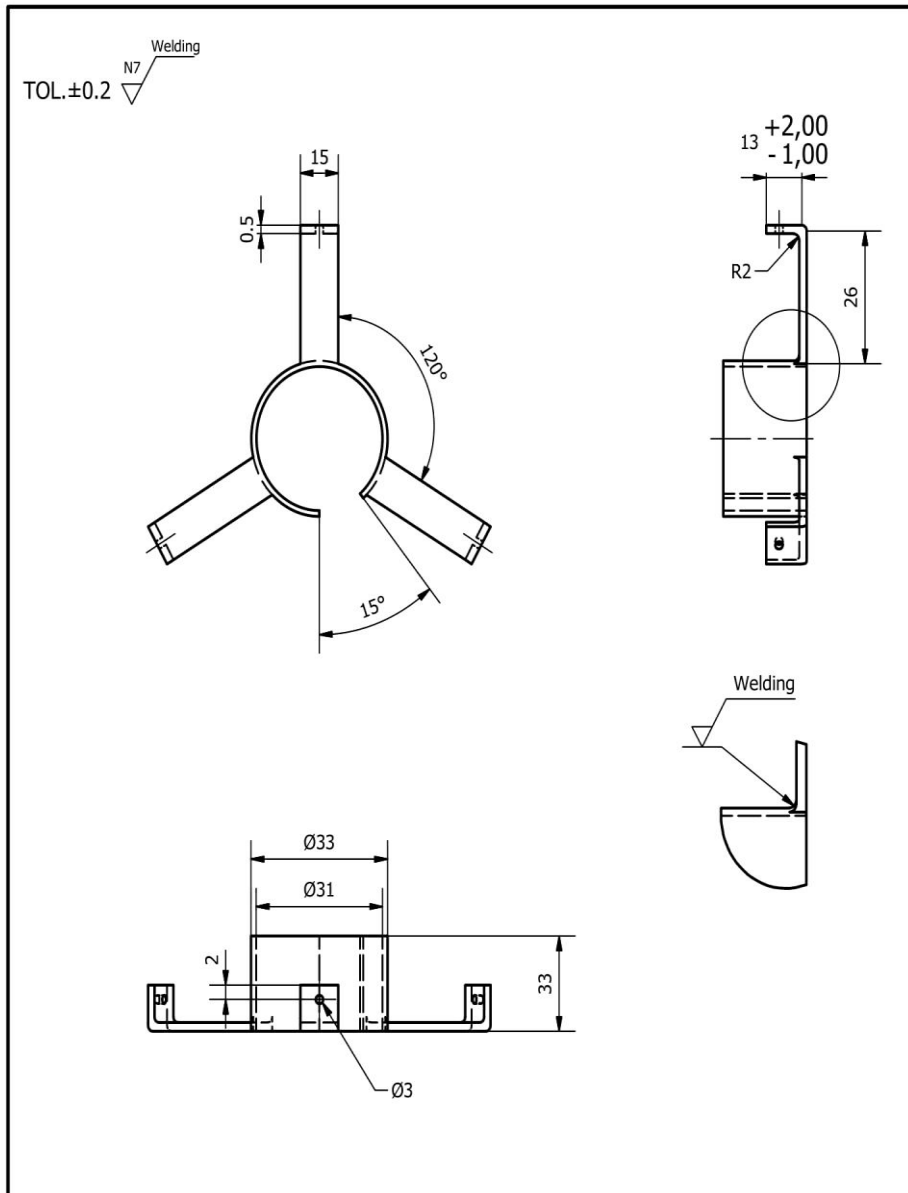

	3	Penyangga Rumah Motor DC	7	Stainless Steel	26 x 13 x Ø33	Dibuat
Jumlah Quantity		Nama Bagian Part Name	No. Bag Part No.	Bahan Material	Ukuran Size	Keterangan Remark
⊕ ⊗ ⊕⊗	Perubahan : Revision					
	Penyangga Rumah Motor DC				Skala Scale 1:2	Digambar Drawn Diperiksa Checked TIM
POLITEKNIK NEGERI SRIWIJAYA Jl. Srijaya Negara Bukit Besar Palembang					DRAME.PART NO.7/2018	

TOL.±02 

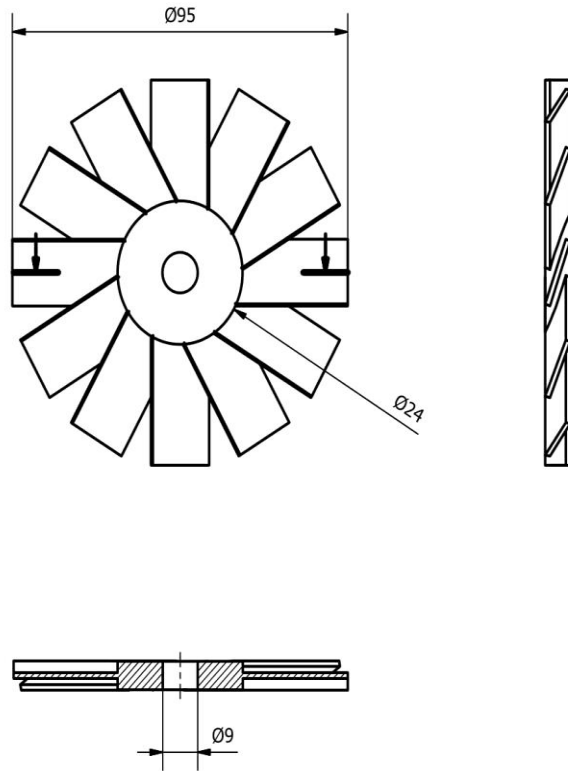

	3	Kipas	3	Aluminium	Ø95	Dibuat	
Jumlah Quantity		Nama Bagian Part Name	No. Bag Part No.	Bahan Material	Ukuran Size	Keterangan Remark	
	Perubahan : Revision						
		Kipas			Skala Scale 1 : 2	Digambar Drawn	TIM
						Diperiksa Checked	
POLITEKNIK NEGERI SRIWIJAYA Jl. Srijaya Negara Bukit Besar Palembang					DRAME.PART NO.3/2018		

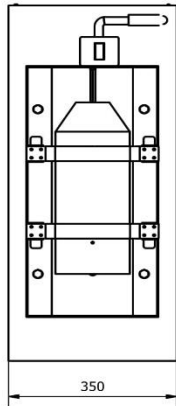
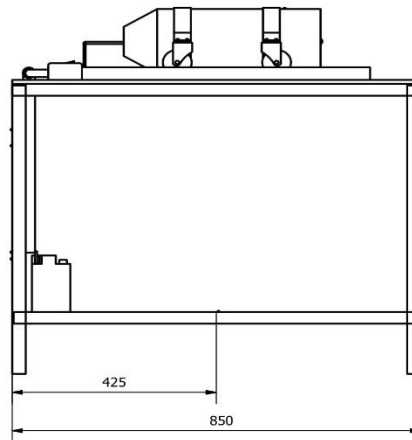
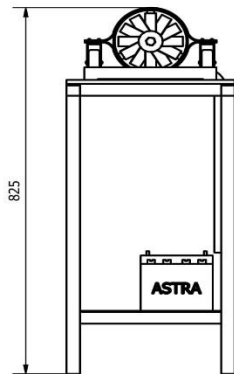

	1	Pipa Listrik	16	PVC	200 x Ø20	Dibeli						
	1	Saklar	15	Standart	Standart	Dibeli						
	1	Kabel Listrik	14	Standart	Standart	Dibeli						
	1	Aki	13	Standart	Standart	Dibeli						
	1	Meja	12	Baja karbon	850 x 350 x 700	Dibuat						
	4	Ban Roller	11	Stainless Steel	Standart	Dibeli						
	4	Kiem	10	Aluminium	189 x 45 x Ø99	Dibuat						
	1	Selimit Mesin	9	Tinplate	250 x Ø100	Dibeli						
	1	Motor DC	8	Standart	55 x Ø36	Dibeli						
	3	Penyangga Rumah Motor DC	7	Stainless steel	26 x 13 x Ø33	Dibuat						
	1	Konektor	6	Aluminium	50 x Ø9	Dibeli						
	1	Hub	5	Alloy	150 x 15	Dibeli						
	6	Penyangga Hub	4	Aluminium	31 x 14	Dibuat						
	3	Kipas	3	Aluminium	Ø95	Dibuat						
	5	Mur	2	Cast Iron	Ø9	Dibeli						
	1	Poros	1	Baja	137 x Ø9	Dibeli						
Jumlah Quantity	Nama Bagian Part Name	No. Bag Part No.	Bahan Material	Ukuran Size	Keterangan Remark							
⊕	×	⋈	Perubahan Revision									
<p style="text-align: center;">Assembly Simulator Penghasil Gaya Dorong</p> <p style="text-align: center;">POLITEKNIK NEGERI SRIWIJAYA Jl. Sriwijaya Negara Bukit Besar Palembang</p>				Skala Scale	1:6	<table border="1"> <tr><td>Digambar Drawn</td><td></td><td>TIM</td></tr> <tr><td>Diperiksa Checked</td><td></td><td></td></tr> </table>	Digambar Drawn		TIM	Diperiksa Checked		
				Digambar Drawn		TIM						
Diperiksa Checked												
DRAME NO:2/TA/2018												

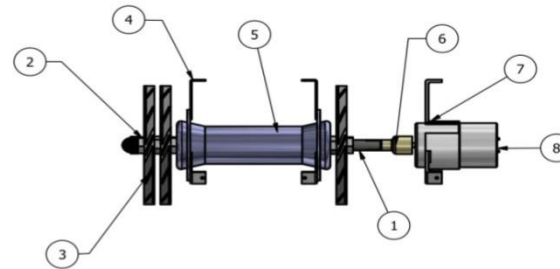
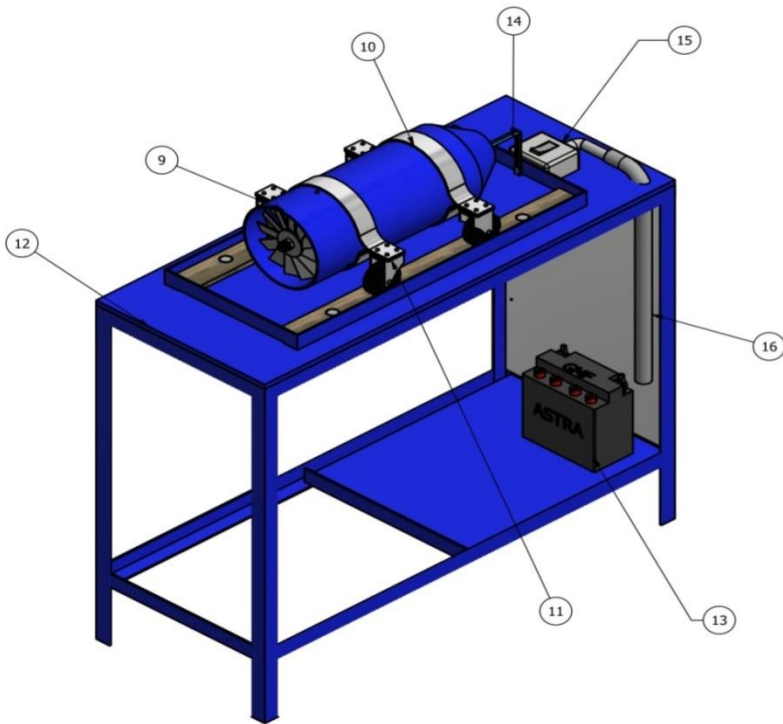

1	Pipa Listrik	16	PVC	200 x Ø20	Dibeli	
1	Saklar	15	Standart	Standart	Dibeli	
1	Kabel Listrik	14	Standart	Standart	Dibeli	
1	Aki	13	Standart	Standart	Dibeli	
1	Meja	12	Baja karbon	850 x 350 x 700	Dibuat	
4	Ban Roller	11	Stainless Steel	Standart	Dibeli	
4	Klem	10	Aluminium	189 x 45 x Ø99	Dibuat	
1	Selimit Mesin	9	Tinplate	250 x Ø100	Dibeli	
1	Motor DC	8	Standart	55 x Ø36	Dibeli	
3	Penyangga Rumah Motor DC	7	Stainless steel	26 x 13 x Ø33	Dibuat	
1	Konektor	6	Aluminium	50 x Ø9	Dibeli	
1	Hub	5	Alloy	150 x 15	Dibeli	
6	Penyangga Hub	4	Aluminium	31 x 14	Dibuat	
3	Kipas	3	Aluminium	Ø95	Dibuat	
5	Mur	2	Cast Iron	Ø9	Dibeli	
1	Poros	1	Baja	137 x Ø9	Dibeli	
Jumlah	Nama Bagian	No. Bag	Bahan	Ukuran	Keterangan	
Quantity	Part Name	Part No.	Material	Size	Remark	
Ø	⌘	⌘	Perubahan Revision			
<p style="text-align: center;">Assembly Simulator Penghasil Gaya Dorong</p> <p style="text-align: center;">POLITEKNIK NEGERI SRIWIJAYA Jl. Srijaya Negara Bukit Besar Palembang</p>				Skala	Digambar	TIM
				Scale	Drawn	
				1:6	Diperiksa	
					Checked	
				DRAME NO:1/TA/2018		