

DAFTAR LAMPIRAN

Detail Gambar Alat *Wet Scurbber*

1. Badan Atas

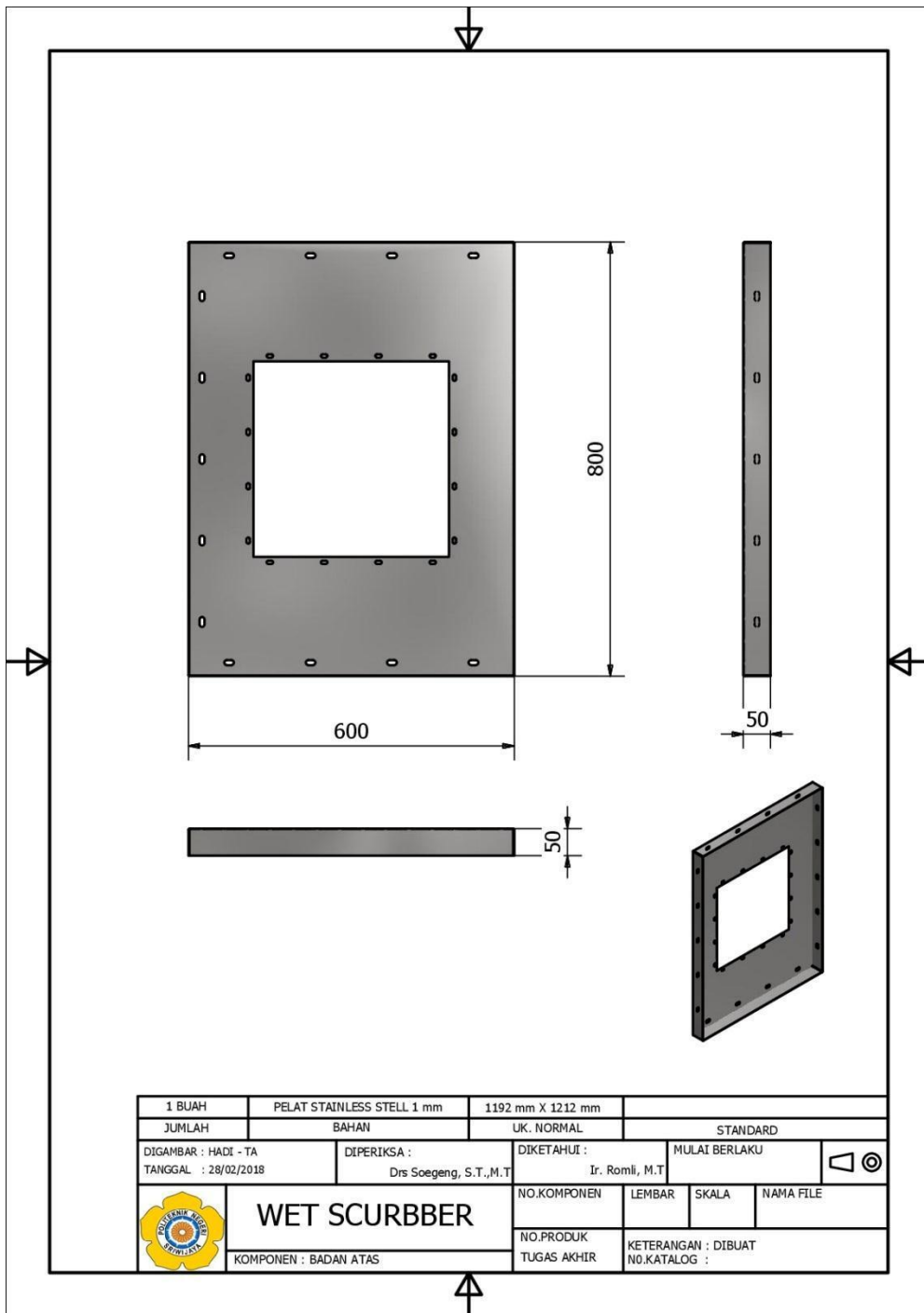

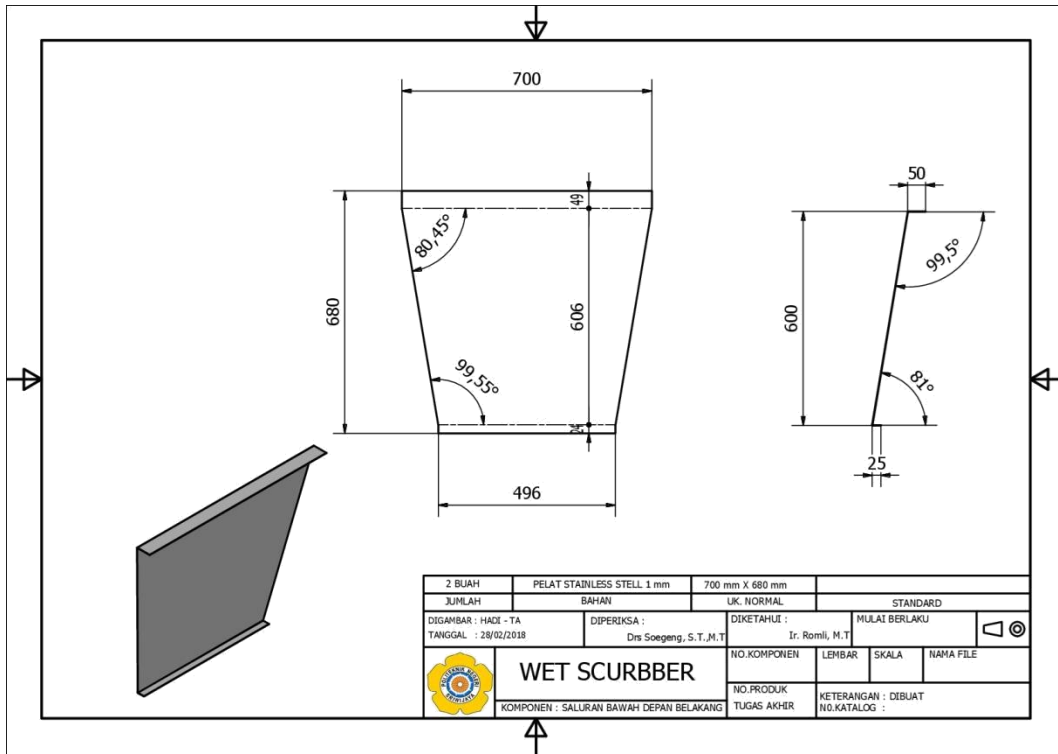

2 BUAH	PELAT STAINLESS STEEL 1 mm	700 mm X 680 mm	STANDARD	
JUMLAH	BAHAN	UK. NORMAL	MULAI BERLAKU	
DIGAMBAR : HADI - TA TANGGAL : 28/02/2018	DIPERIKSA : Drs Soegeng, S.T.,M.T	DIKETAHLUI : Ir. Romli, M.T		
	WET SCURBBER		NO. KOMPONEN	LEMBAR
			SKALA	NAMA FILE
KOMPONEN : SALLURAN BAWAH DEPAN BELAKANG		NO. PRODUK	KETERANGAN : DIBUAT	
		TUGAS AKHIR	NO. KATALOG :	

2. Badan Atas Bentangan

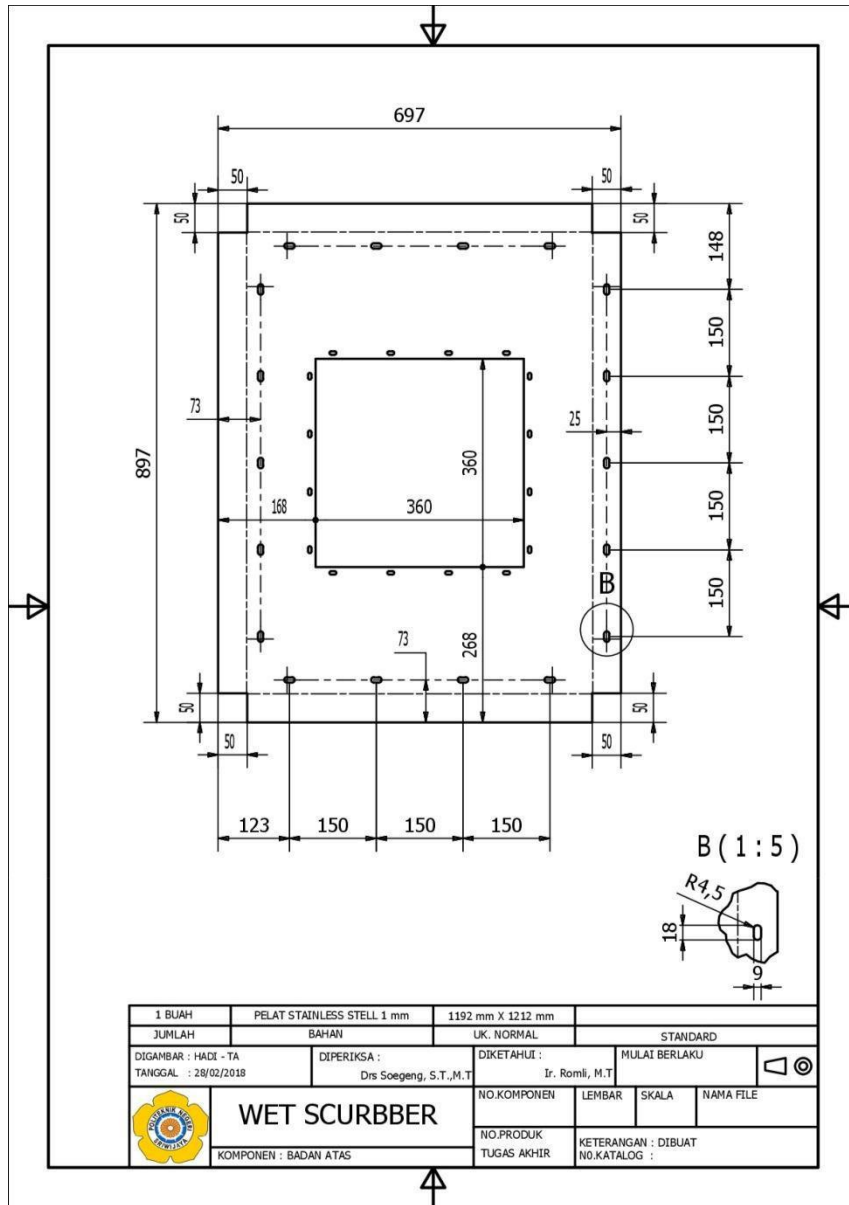

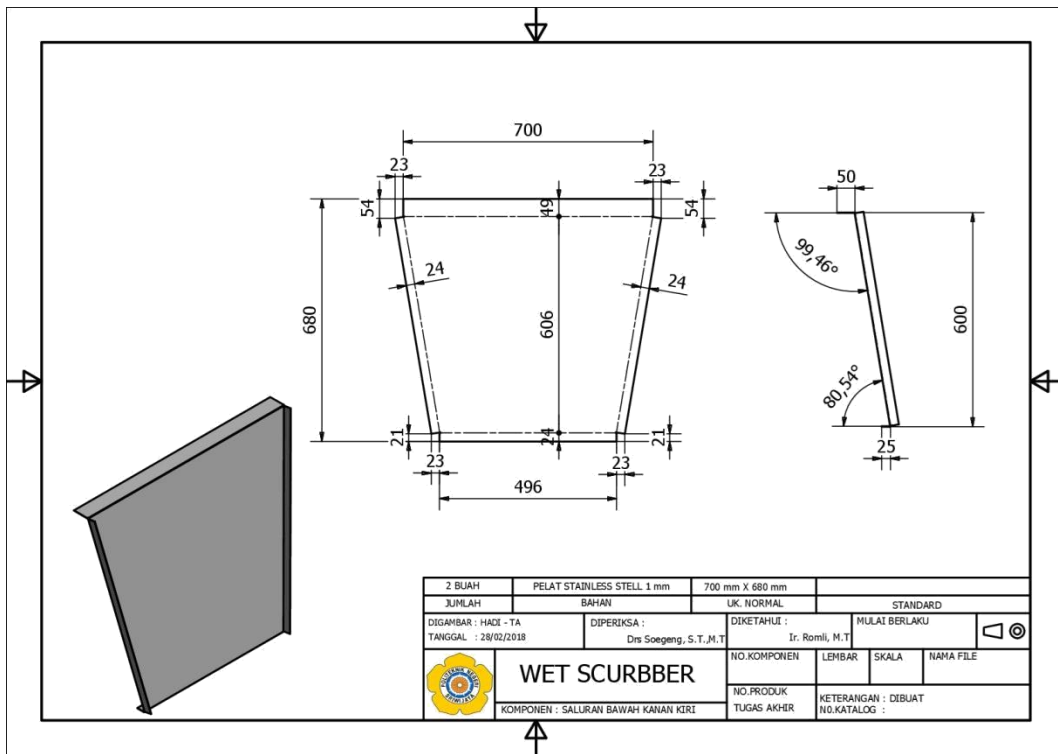

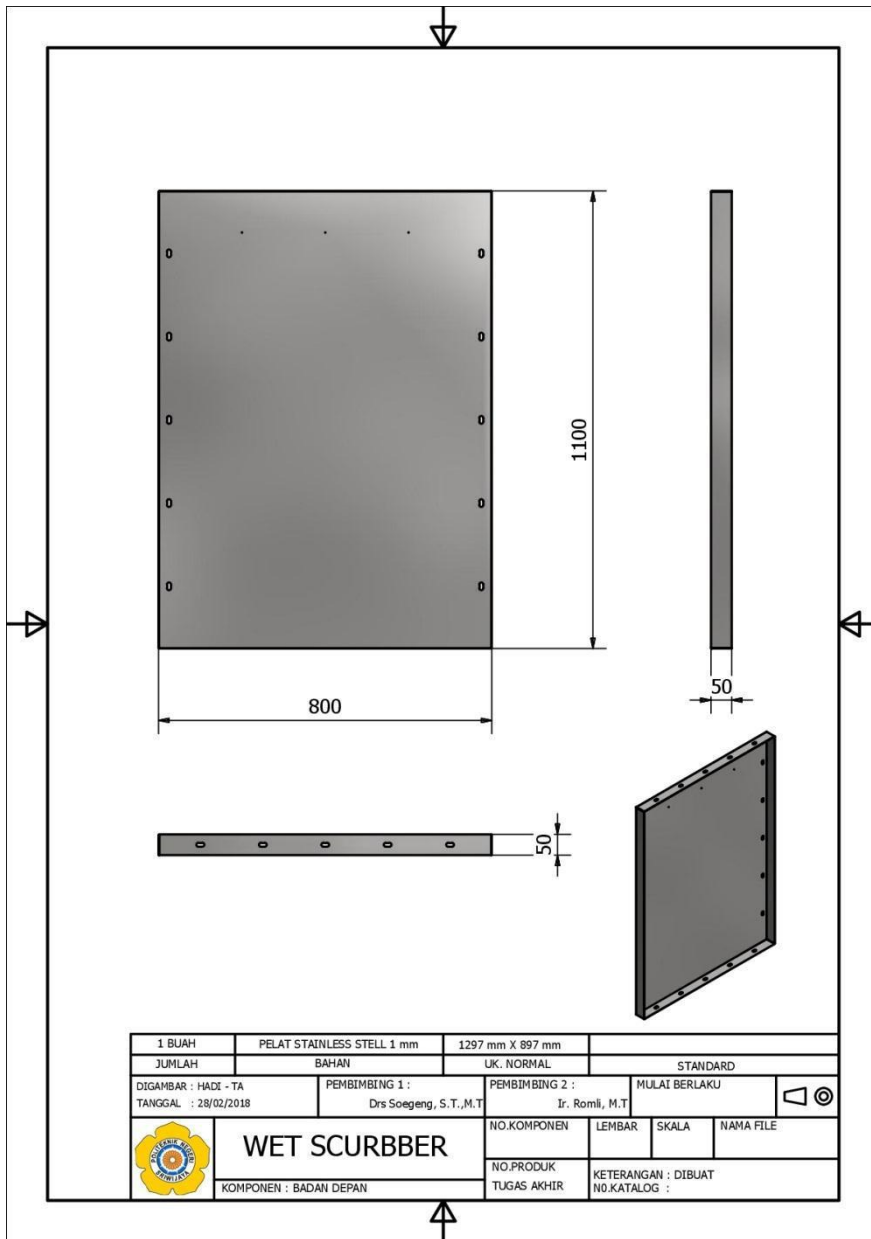

3. BadanDepan

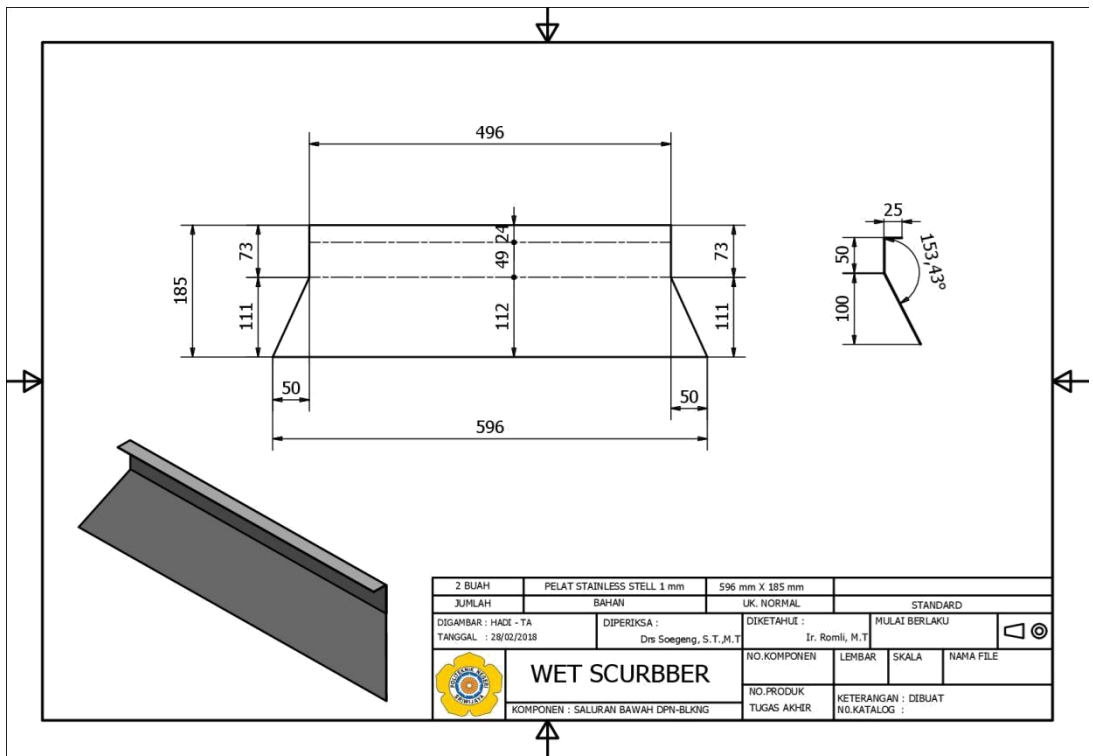

1 BUAH	PELAT STAINLESS STEEL 1 mm	1297 mm X 897 mm	STANDARD		
JUMLAH	BAHAN	UK. NORMAL	MULAI BERLAKU		
DIGAMBAR : HADI - TA TANGGAL : 28/02/2018	PEMBIMBING 1 : Drs Soegeng, S.T.,M.T	PEMBIMBING 2 : Ir. Romli, M.T			
	WET SCURBBER KOMPONEN : BADAN DEPAN	NO.KOMPONEN	LEMBAR	SKALA	NAMA FILE
		NO.PRODUK TUGAS AKHIR	KETERANGAN : DIBUAT NO.KATALOG :		



2 BUAH	PELAT STAINLESS STEEL 1 mm	596 mm X 185 mm	STANDARD	
JUMLAH	BAHAN	UK. NORMAL	MULAI BERLAKU	
DIGAMBAR : HADI - TA	DIPERIKSA : Drs Soegeng, S.T.,M.T	DIKETAHUI : Ir. Romli, M.T		
TANGGAL : 28/02/2018			NO. KOMPONEN	LEMBAR
	WET SCURBBER	NO. PRODUK	SKALA	NAMA FILE
		KOMPONEN : SALLURAN BAWAH DPN-BUKING	TUGAS AKHIR	KETERANGAN : DIBUAT NO.KATALOG :

4. Badan Depan Bentangan

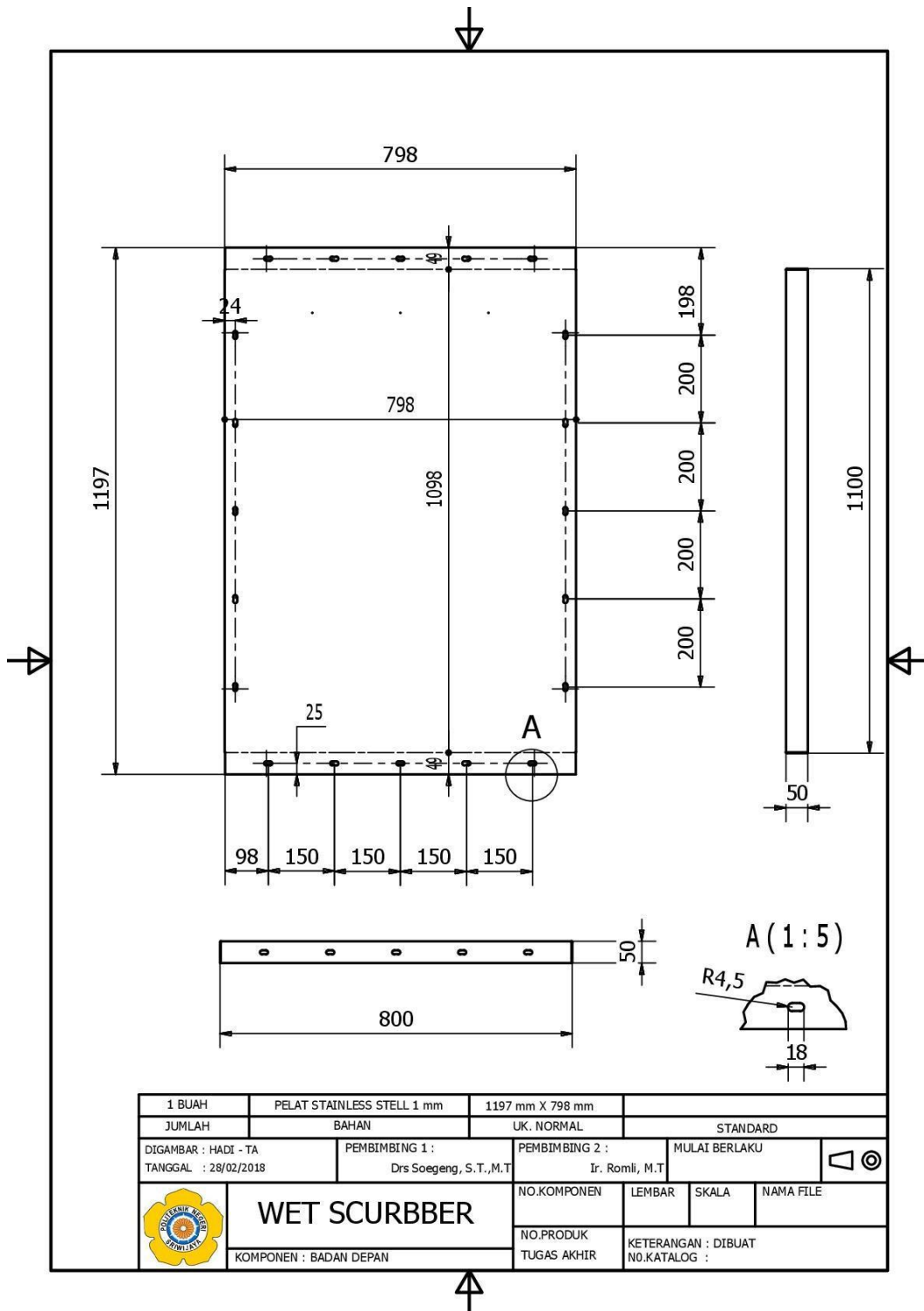

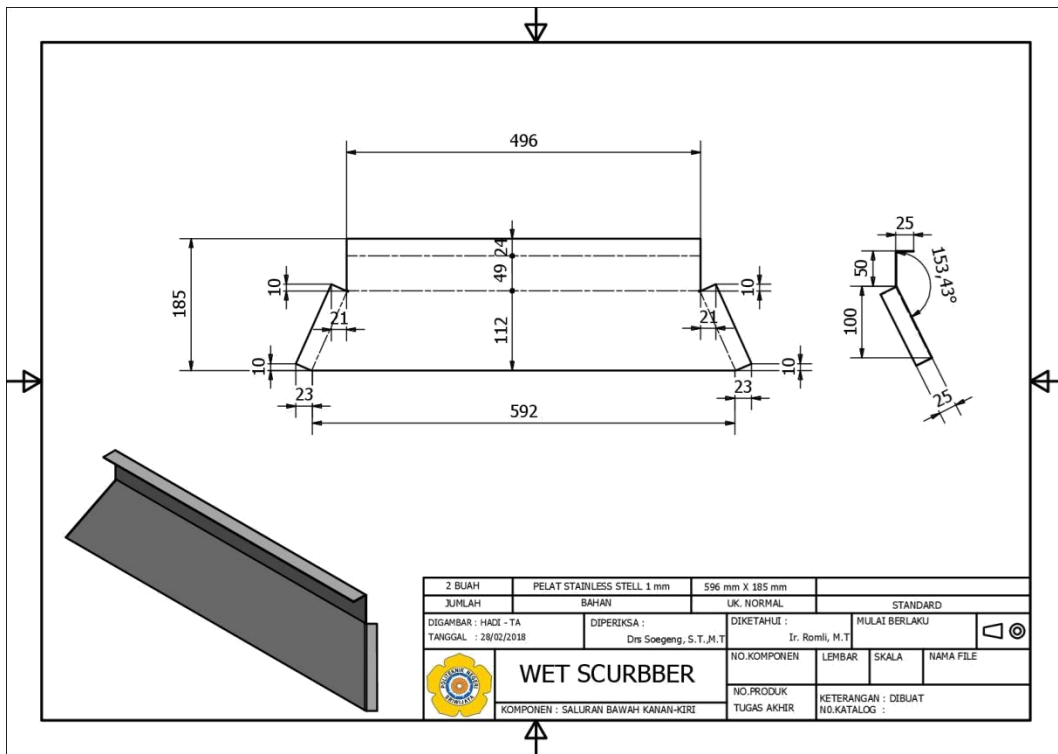

5. Badan Kanan

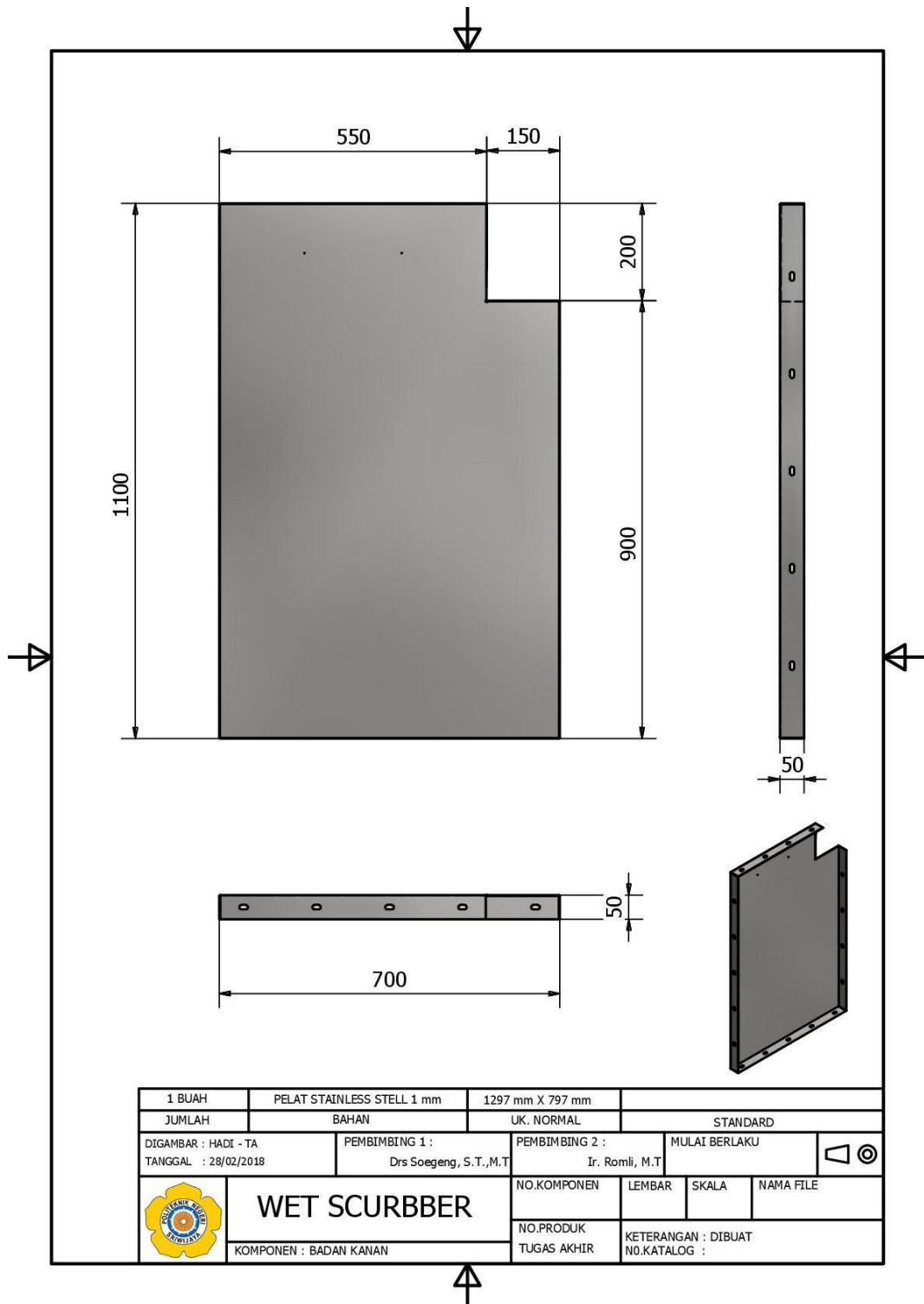

1 BUAH	PELAT STAINLESS STEEL 1 mm	1297 mm X 797 mm			
JUMLAH	BAHAN	UK. NORMAL	STANDARD		
DIGAMBAR : HADI - TA TANGGAL : 28/02/2018	PEMBIMBING 1 : Drs Soegeng, S.T.,M.T	PEMBIMBING 2 : Ir. Romli, M.T	MULAI BERLAKU	◀ ◎	
	WET SCURBBER KOMPONEN : BADAN KANAN	NO.KOMPONEN	LEMBAR	SKALA	NAMA FILE
		NO.PRODUK TUGAS AKHIR	KETERANGAN : DIBUAT NO.KATALOG :		

6. Badan Kanan Bentangan

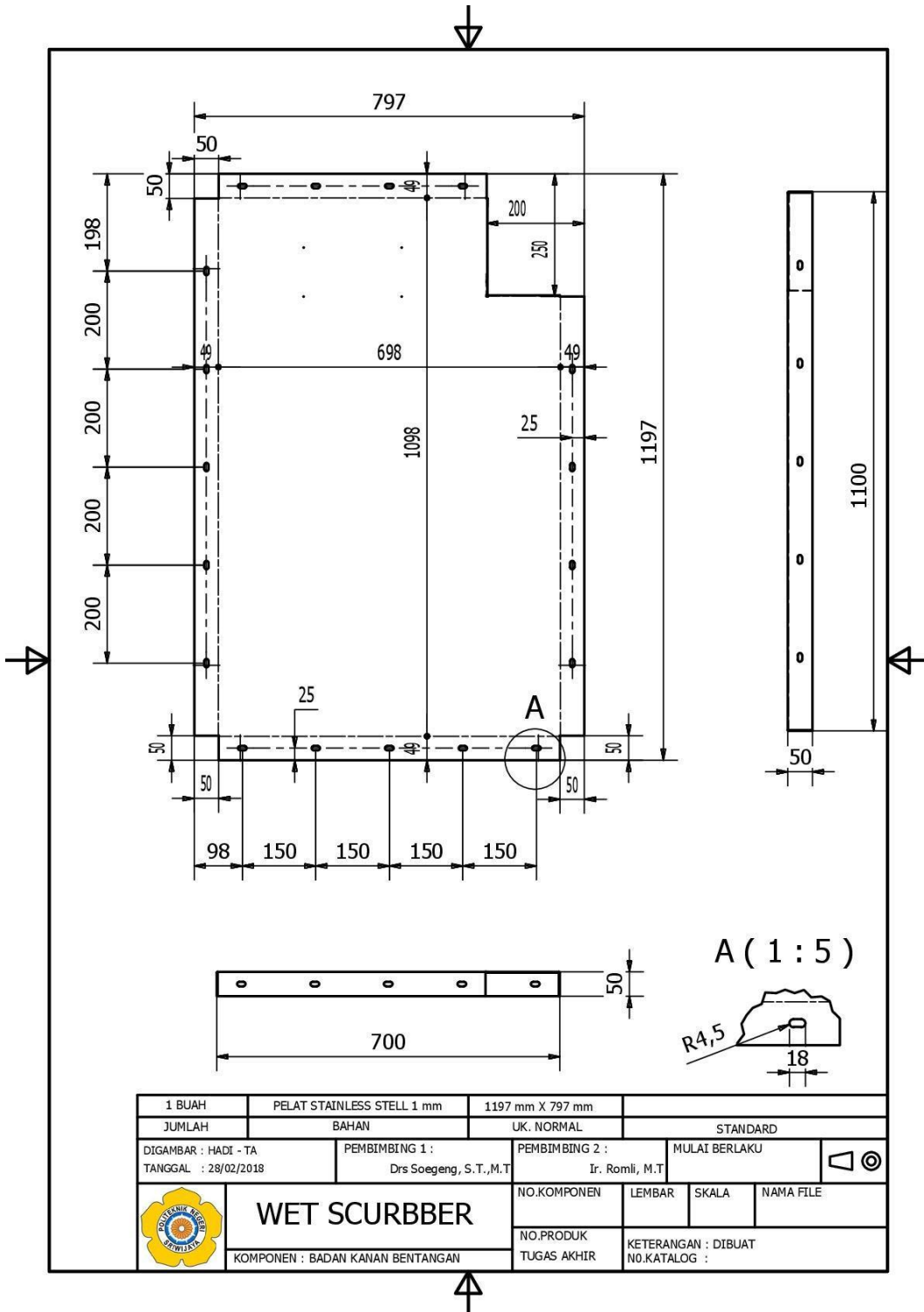

7. Badan Kiri

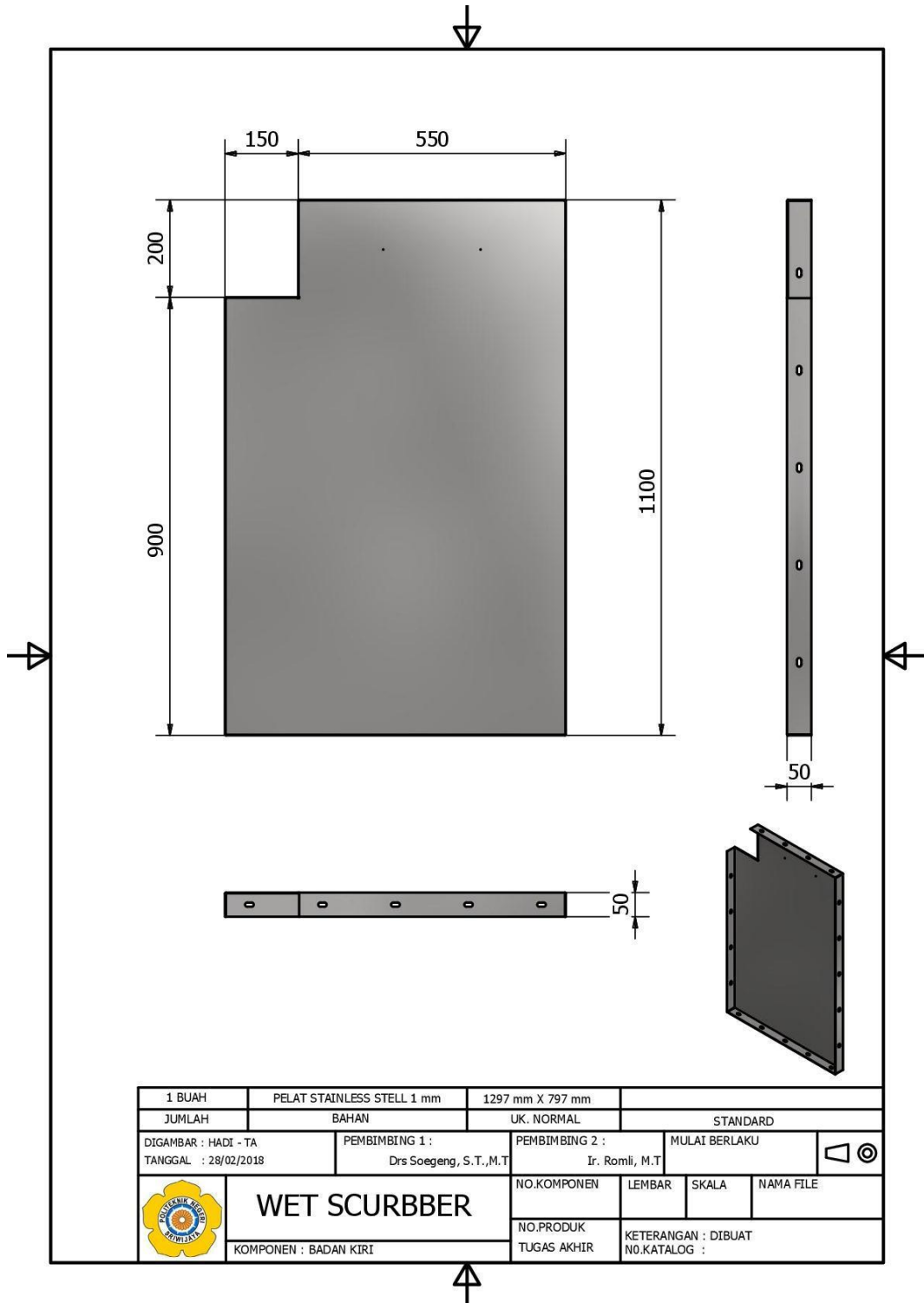

1 BUAH	PELAT STAINLESS STEEL 1 mm	1297 mm X 797 mm			
JUMLAH	BAHAN	UK. NORMAL	STANDARD		
DIGAMBAR : HADI - TA	PEMBIMBING 1 :	PEMBIMBING 2 :	MULAI BERLAKU		◀ ◎
TANGGAL : 28/02/2018	Drs Soegeng, S.T.,M.T	Ir. Romli, M.T			
	WET SCURBBER KOMPONEN : BADAN KIRI	NO.KOMPONEN	LEMBAR	SKALA	NAMA FILE
		NO.PRODUK TUGAS AKHIR	KETERANGAN : DIBUAT NO.KATALOG :		

8. Badan Kiri Bentangan

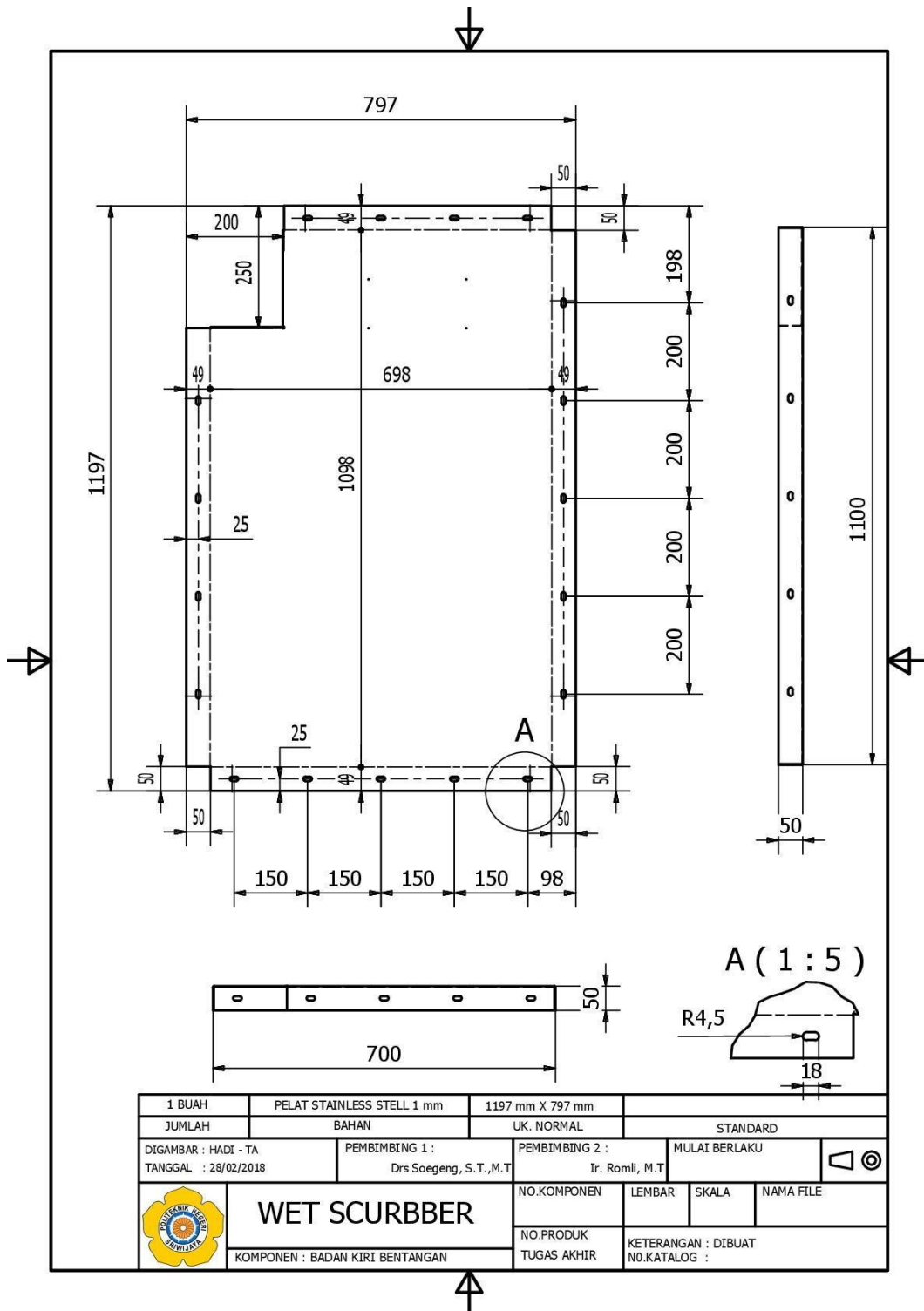

8.1 Frame

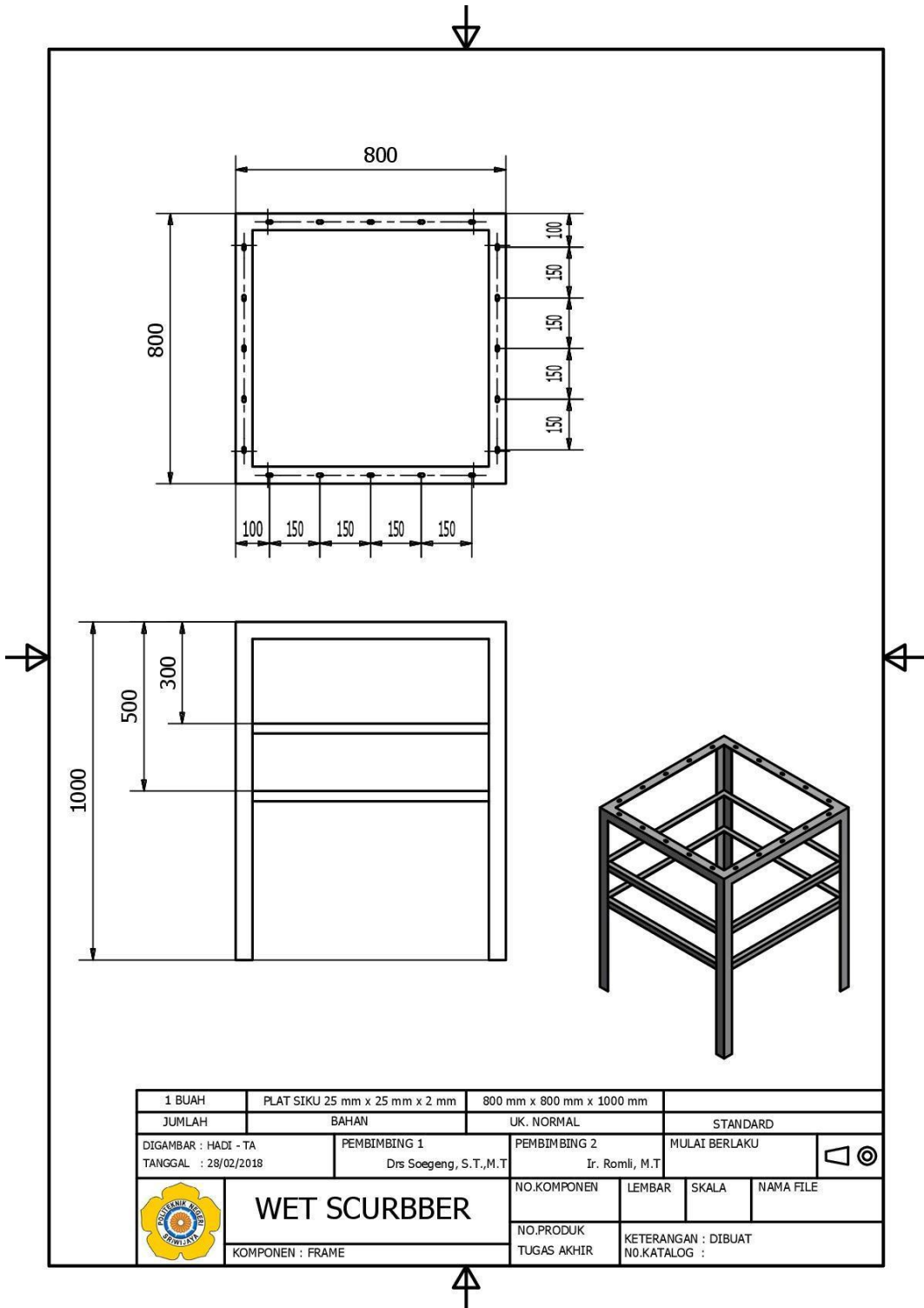

1 BUAH	PLAT SIKU 25 mm x 25 mm x 2 mm	800 mm x 800 mm x 1000 mm			
JUMLAH	BAHAN	UK. NORMAL	STANDARD		
DIGAMBAR : HADI - TA	PEMBIMBING 1	PEMBIMBING 2	MULAI BERLAKU		◀ ◎
TANGGAL : 28/02/2018	Drs Soegeng, S.T.,M.T	Ir. Romli, M.T			
	WET SCURBBER KOMPONEN : FRAME	NO.KOMPONEN	LEMBAR	SKALA	NAMA FILE
		NO.PRODUK TUGAS AKHIR	KETERANGAN : DIBUAT NO.KATALOG :		

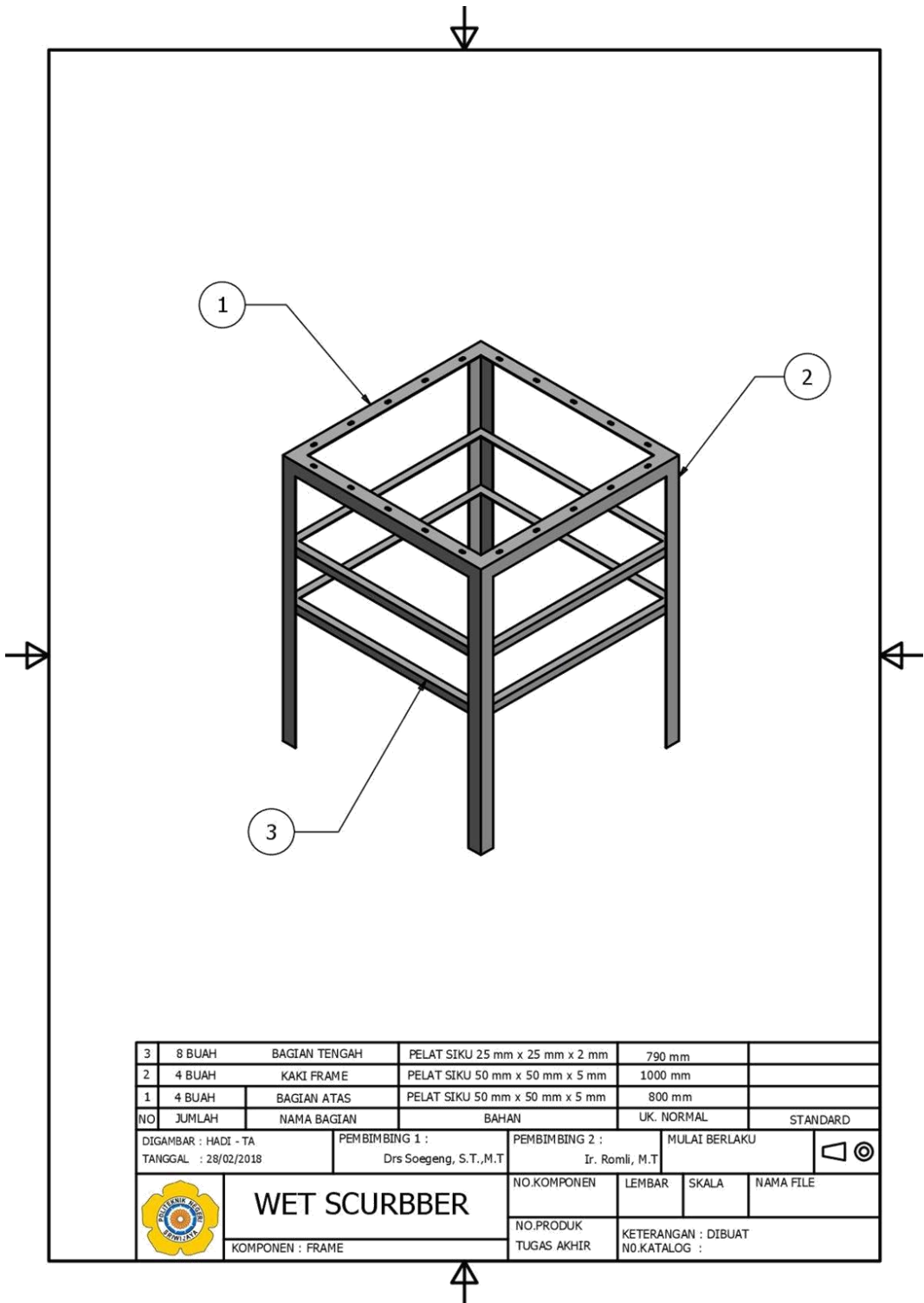

3	8 BUAH	BAGIAN TENGAH	PELAT SIKU 25 mm x 25 mm x 2 mm	790 mm	
2	4 BUAH	KAKI FRAME	PELAT SIKU 50 mm x 50 mm x 5 mm	1000 mm	
1	4 BUAH	BAGIAN ATAS	PELAT SIKU 50 mm x 50 mm x 5 mm	800 mm	
NO	JUMLAH	NAMA BAGIAN	BAHAN	UK. NORMAL	STANDARD
DIGAMBAR : HADI - TA		PEMBIMBING 1 :		PEMBIMBING 2 :	
TANGGAL : 28/02/2018		Drs Soegeng, S.T.,M.T		Ir. Romli, M.T	
				MULAI BERLAKU	
		WET SCURBBER		NO.KOMPONEN	LEMBAR
KOMPONEN : FRAME				SKALA	NAMA FILE
				NO.PRODUK	KETERANGAN : DIBUAT
				TUGAS AKHIR	NO.KATALOG :

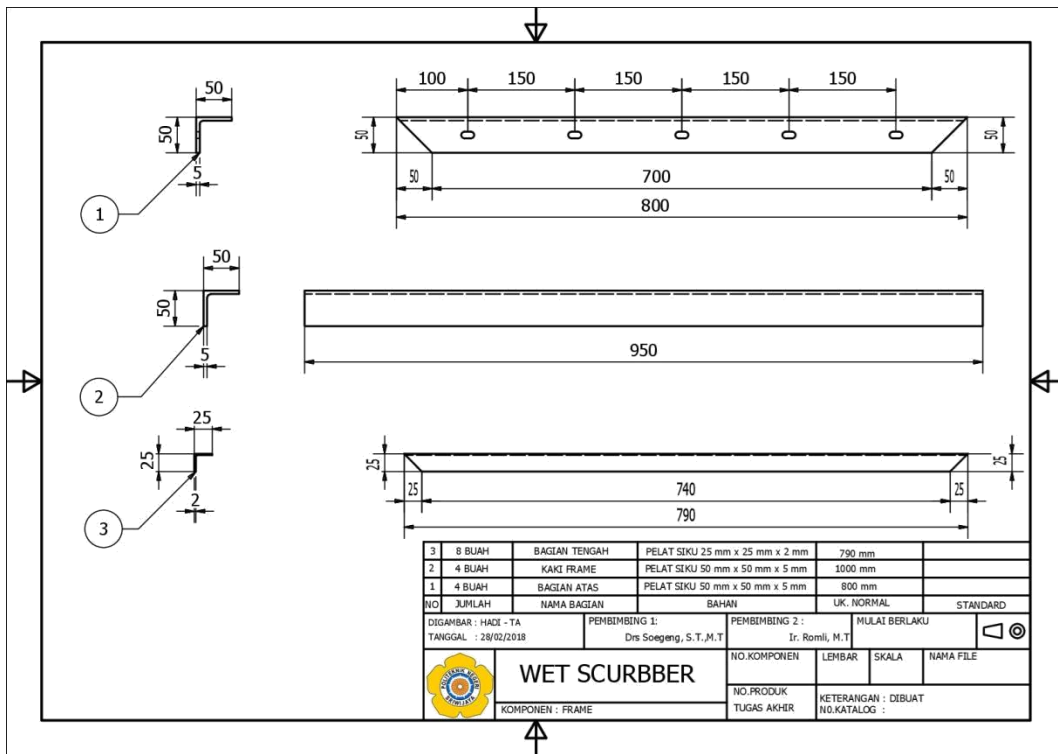

9. BadanBelakang

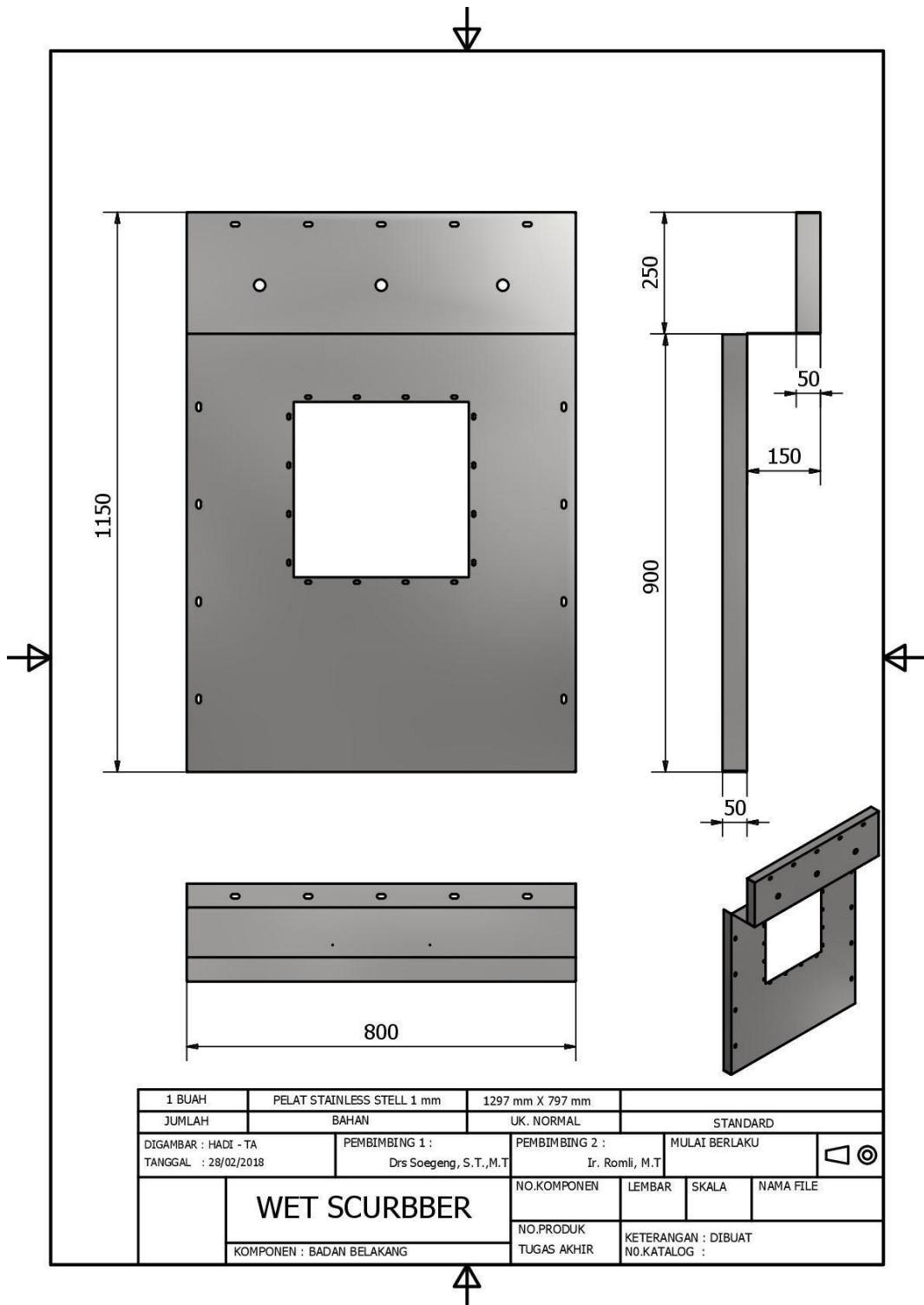

10. Saluran Input Asap Tee

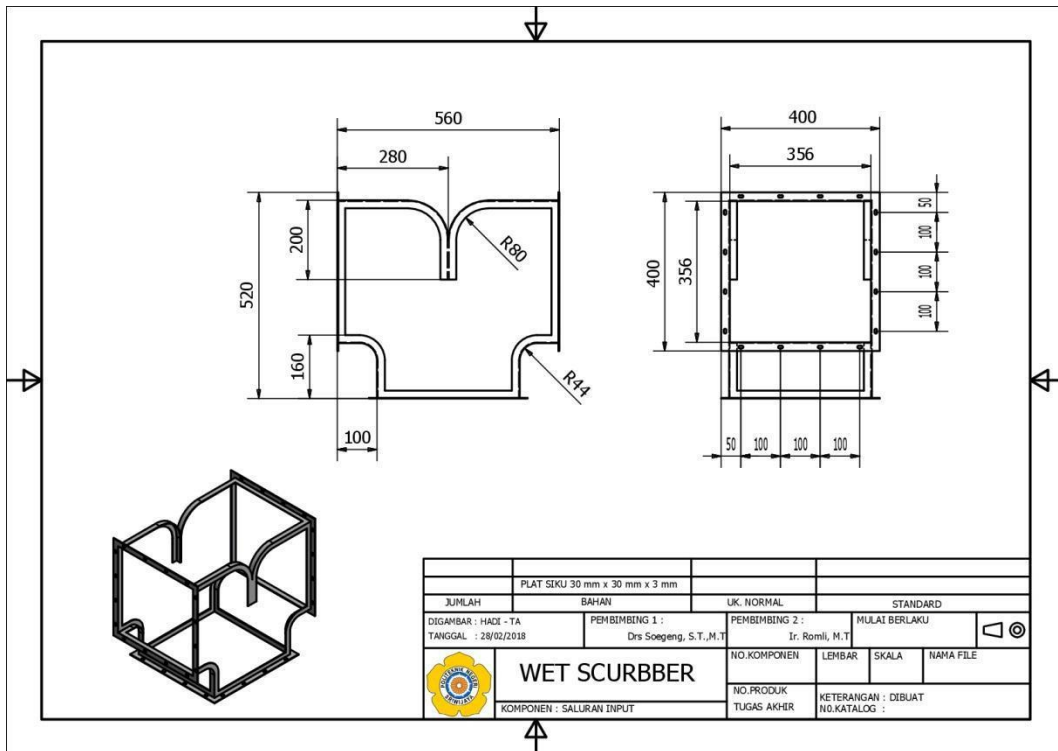

10.1 Assembly Saluran Input

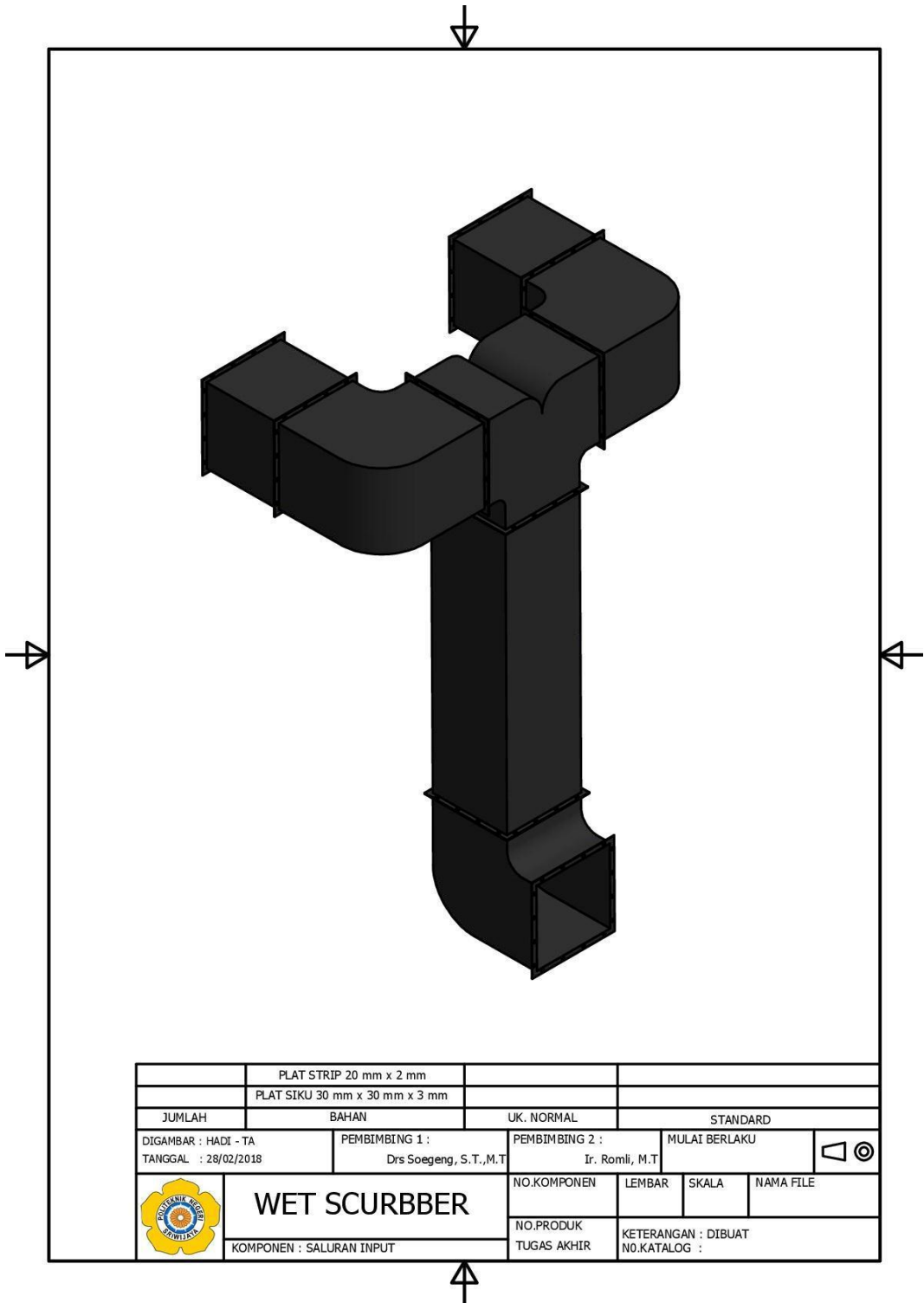

10.2 Assembly Saluran Input 2

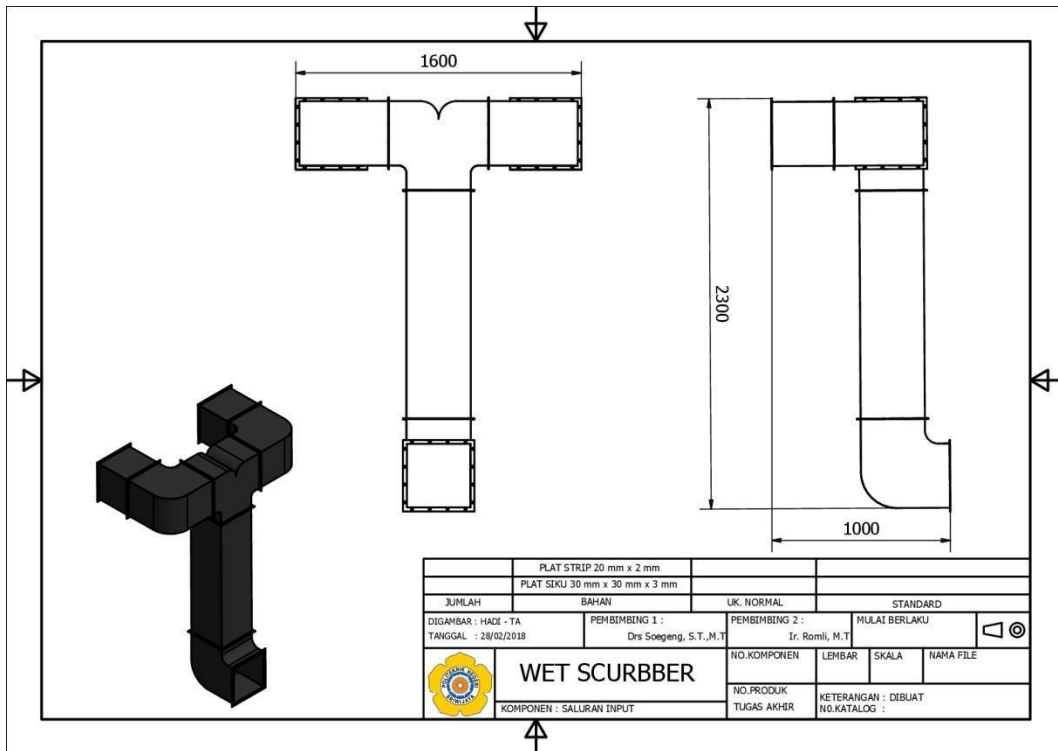

10.3 BadanBelakangBentangan

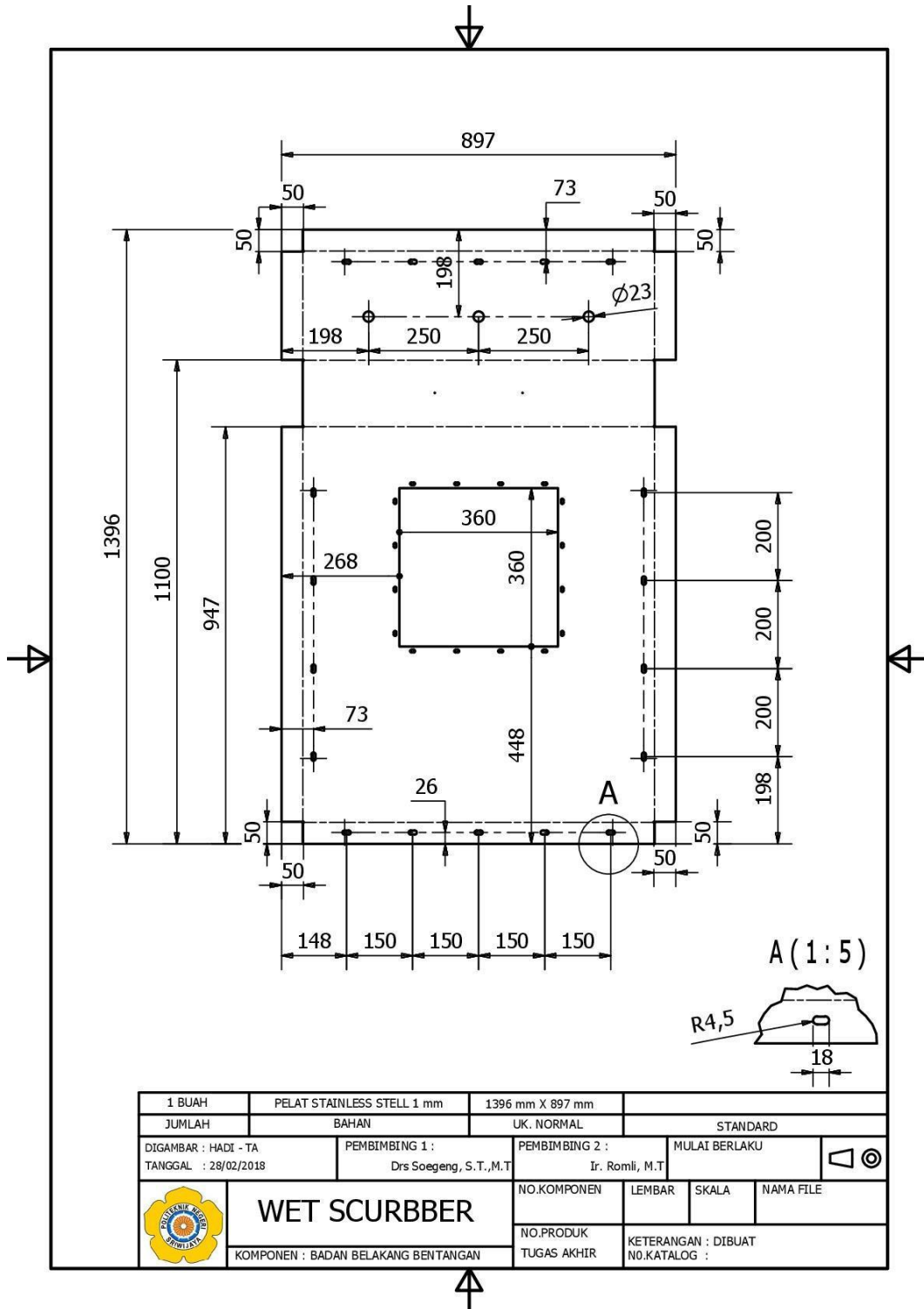

10.4 Saluran Input 360x360x500

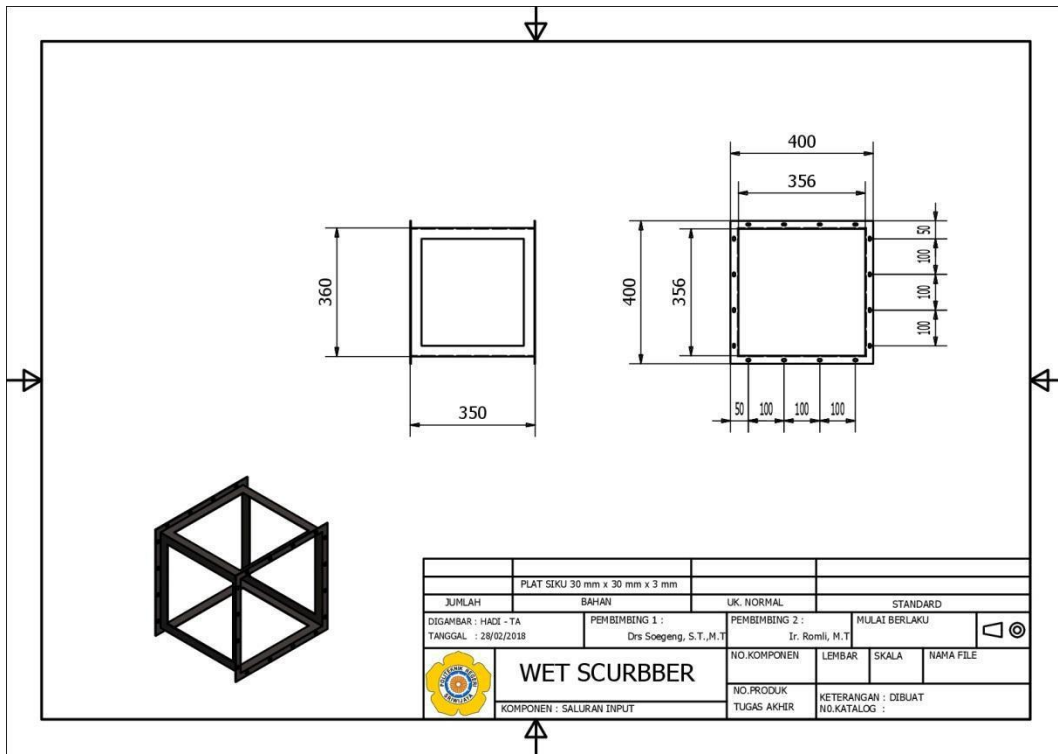

10.5 Saluran Input 1000x360x360

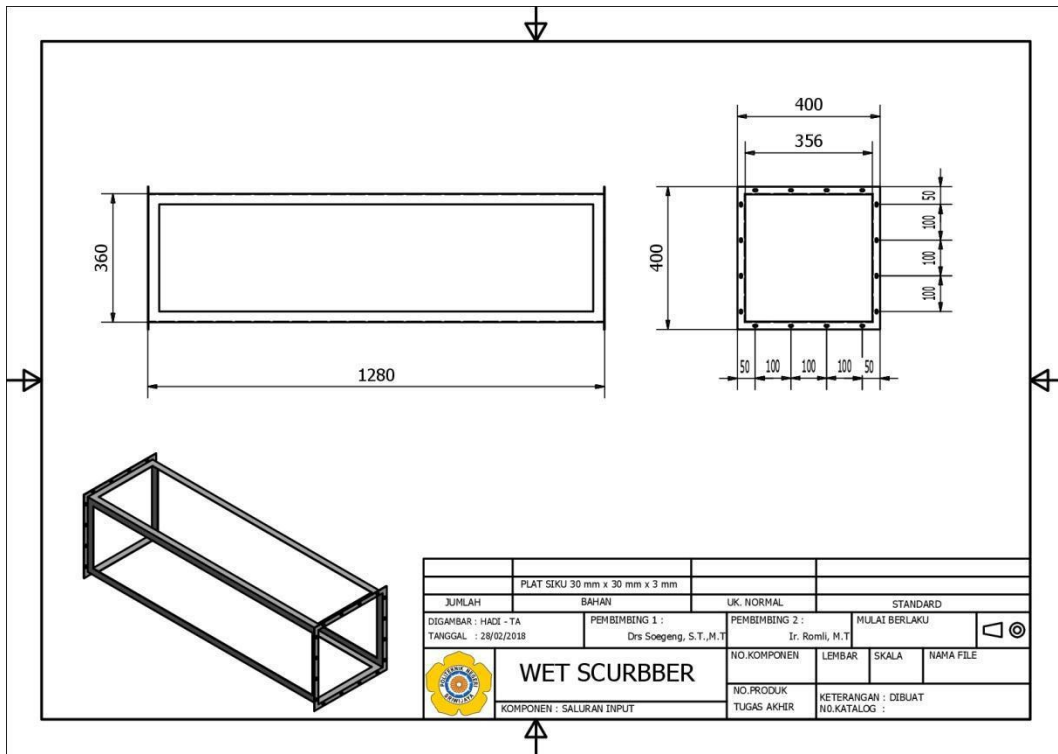

11. Saluran Input Asap Elbow

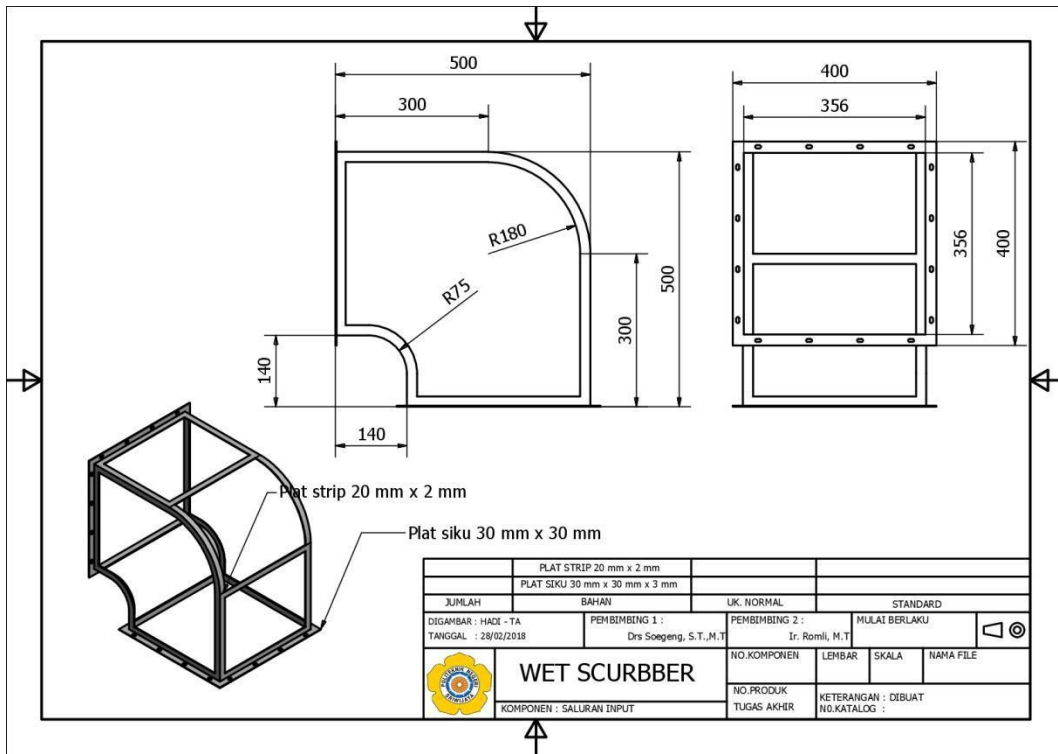

12. Saluran Output

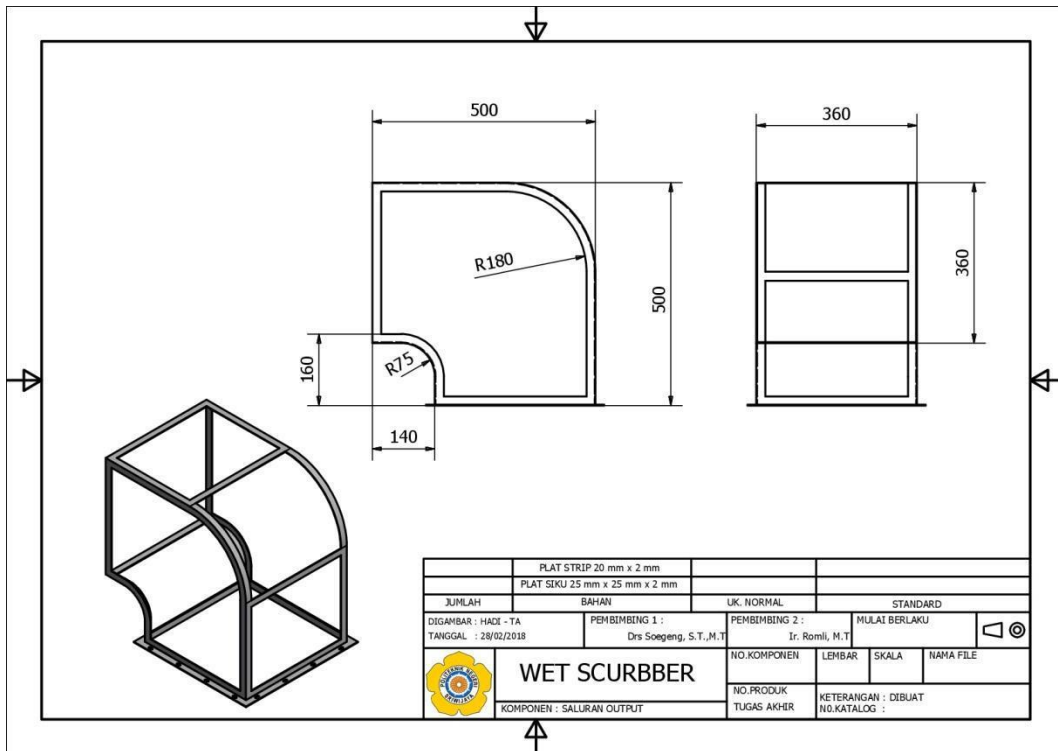

13. Frame PenyanggaPipa Nozzle

