

LAMPIRAN

Spesifikasi Tungku Pelebur

1. Dimensi Dapur

- Diameter Dinding Luar : 312 mm
- Diameter Dinding Dalam : 262 mm
- Tinggi Dapur : 251 mm

2. Cawan Lebur

- Tinggi Cawan : 170 mm
- Diameter : 260 mm
- Tebal Cawan : 3 mm

3. Peredam Panas

- Jenis : *Glasswool*
- Jumlah : 26 pcs

4. Penahan Heater

Pada alat ini, kami menggunakan mortar atau semen tahan api sebagai penahan heater karena juga memiliki kemampuan untuk menahan panas.

5. Temperatur

Temperatur Lebur Aluminium : 660°C

6. Kebutuhan Kalor

- Kalor total yang diserap dapur : 15.783,552 kJ
- Kalor yang terbuang : 574,238 KJ/Jam

7. Waktu Peleburan

- Pemanasan Awal : 1 Jam
- Waktu total peleburan : 108,324 menit

Daftar A-5 Sifat-sifat Udara pada Tekanan Atmosfer†

Nilai μ , k , c_p , dan Pr tidak terlalu bergantung pada tekanan dan dapat digunakan untuk rentang tekanan yang cukup luas.

T , K	ρ kg/m ³	c_p kJ/kg · °C	μ kg/m · s × 10 ⁵	ν m ² /s × 10 ⁶	k W/m · °C	α m ² /s × 10 ⁴	Pr
100	3.6010	1.0266	0.6924	1.923	0.019246	0.02501	0.770
150	2.3675	1.0099	1.0283	4.343	0.013735	0.05745	0.753
200	1.7684	1.0061	1.3289	7.490	0.01009	0.10165	0.739
250	1.4128	1.0053	1.5990	11.31	0.02227	0.15675	0.722
300	1.1774	1.0057	1.8462	15.69	0.02624	0.22160	0.708
350	0.9980	1.0090	2.075	20.76	0.03003	0.2983	0.697
400	0.8826	1.0140	2.286	25.90	0.03365	0.3760	0.689
450	0.7833	1.0207	2.484	31.71	0.03707	0.4222	0.683
500	0.7048	1.0295	2.671	37.90	0.04038	0.5564	0.680
550	0.6423	1.0392	2.848	44.34	0.04360	0.6532	0.680
600	0.5879	1.0551	3.018	51.34	0.04659	0.7512	0.680
650	0.5430	1.0635	3.177	58.51	0.04953	0.8578	0.682
700	0.5030	1.0752	3.332	66.25	0.05230	0.9672	0.684
750	0.4709	1.0856	3.481	73.91	0.05509	1.0774	0.686
800	0.4405	1.0978	3.625	82.29	0.05779	1.1951	0.689
850	0.4149	1.1095	3.765	90.75	0.06028	1.3097	0.692
900	0.3925	1.1212	3.899	99.3	0.06279	1.4271	0.696
950	0.3716	1.1321	4.023	108.2	0.06525	1.5510	0.699
1000	0.3524	1.1417	4.152	117.8	0.06752	1.6779	0.702
1100	0.3204	1.160	4.44	138.6	0.0732	1.969	0.704
1200	0.2947	1.179	4.69	159.1	0.0782	2.251	0.707
1300	0.2707	1.197	4.93	182.1	0.0837	2.583	0.705
1400	0.2515	1.214	5.17	205.5	0.0891	2.920	0.705
1500	0.2355	1.230	5.40	229.1	0.0946	3.262	0.705
1600	0.2211	1.248	5.63	254.5	0.100	3.609	0.705
1700	0.2082	1.267	5.85	280.5	0.105	3.977	0.705
1800	0.1970	1.287	6.07	308.1	0.111	4.379	0.704
1900	0.1858	1.309	6.29	338.5	0.117	4.811	0.704
2000	0.1762	1.338	6.50	369.0	0.124	5.260	0.702
2100	0.1682	1.372	6.72	399.6	0.131	5.715	0.700
2200	0.1602	1.419	6.93	432.6	0.139	6.120	0.707
2300	0.1538	1.482	7.14	464.0	0.149	6.540	0.710
2400	0.1458	1.574	7.35	504.0	0.161	7.020	0.718
2500	0.1394	1.638	7.57	543.5	0.175	7.441	0.730

† Dari *Natl. Bur. Stand. (U.S.) Circ. 564, 1965*

Daftar ini menggunakan satuan SI.

$\frac{x}{2\sqrt{at}}$	$\frac{erf \frac{x}{2\sqrt{at}}}{\frac{x}{2\sqrt{at}}}$	$\frac{x}{2\sqrt{at}}$	$\frac{erf \frac{x}{2\sqrt{at}}}{\frac{x}{2\sqrt{at}}}$	$\frac{x}{2\sqrt{at}}$	$\frac{erf \frac{x}{2\sqrt{at}}}{\frac{x}{2\sqrt{at}}}$
0.50	0.52050	1.26	0.92524	2.10	0.997020
0.52	0.53790	1.28	0.92973	2.20	0.998137
0.54	0.55494	1.30	0.93401	2.30	0.998857
0.56	0.57162	1.32	0.93806	2.40	0.999311
0.58	0.58792	1.34	0.94191	2.50	0.999593
0.60	0.60386	1.36	0.94556	2.60	0.999764
0.62	0.61941	1.38	0.94902	2.70	0.999866
0.64	0.63459	1.40	0.95228	2.80	0.999925
0.66	0.64938	1.42	0.95538	2.90	0.999959
0.68	0.66278	1.44	0.95830	3.00	0.999978
0.70	0.67780	1.46	0.96105	3.20	0.999994
0.72	0.69143	1.48	0.96365	3.40	0.999998
0.74	0.70468	1.50	0.96610	3.60	1.000000

Daftar ini menggunakan Satuan SI.

Daftar A-2 Nilai Sifat-sifat Logam† (lanjutan)

Logam	Sifat-sifat pada 20°C					Konduktivitas termal k, W/m · °C										
	ρ , kg/m ³	c_p , kJ/kg · °C	k , W · m · °C	α , m ² /s × 10 ⁵	°C											
					-100°C -148°F	0°C 32°F	100°C 212°F	200°C 392°F	300°C 572°F	400°C 752°F	600°C 1112°F	800°C 1472°F	1000°C 1832°F	1200°C 2192°F		
Aluminum: Murni	2.707	0.896	204	8.418	215	202	206	215	228	249						
Al-Cu (Duralumin), 94-96% Al, 3-5% Cu, runtu Mg	2.787	0.883	164	6.676	126	159	182	194								
Al-Si (Silumin, mengandung tembaga), 86.5% Al, 1% Cu	2.659	0.867	137	5.933	119	137	144	152	161							
Al-Si (Alusil), 78-80% Al, 20-22% Si	2.627	0.854	161	7.172	144	157	168	175	178							
Al-Mg-Si, 97% Al, 1% Mg, 1% Si, 1% Mn	2.707	0.892	177	7.311		175	189	204								
Timbal	11.373	0.130	35	2.343	36.9	35.1	33.4	31.5	29.8							
Besi: Murni	7.897	0.452	73	2.034	87	73	67	62	55	48	48	45	48	40	36	35
Besi Tempa, 0.5% C	7.849	0.46	59	1.626		59	57	52	48	45	45	45	45	36	33	33
Baja (C maks = 1.5%): Baja karbon C = 0.5%	7.833	0.465	54	1.474		55	52	48	45	42	35	31	29	28	28	29
1.0%	7.801	0.473	43	1.172		43	43	42	40	36	33	29	28	28	28	29
1.5%	7.753	0.486	36	0.970		36	36	36	35	33	31	28	28	28	28	29
Baja nikel Ni = 0%	7.897	0.452	73	2.026												
20%	7.933	0.46	19	0.526												

Daftar ini menggunakan Satuan SI.

Tol.: ± 0,05

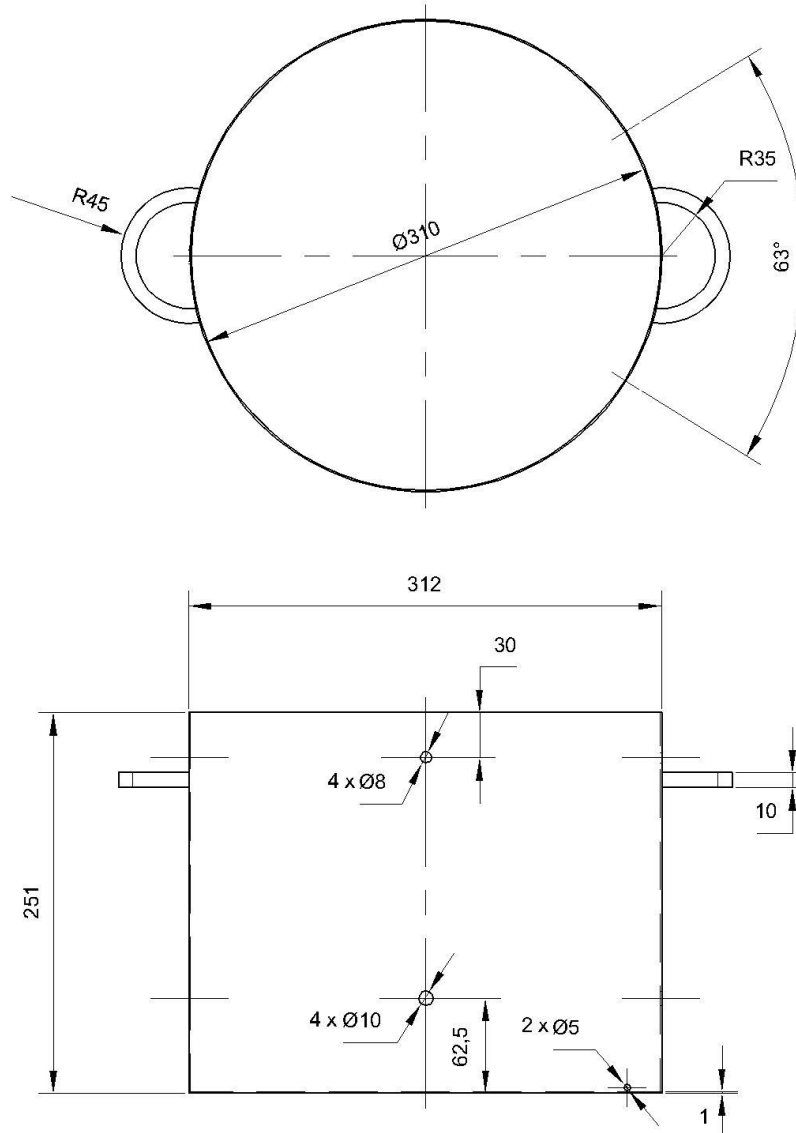

		1	Badan Tungku	1	Plate	$\text{Ø}310 \times 250$ mm	Dibuat	
JUMLAH		NAMA BAGIAN		NO. BAGIAN	BAHAN	UKURAN	KETERANGAN	
III	II	I	Perubahan:					
Sub Assembling Tutup Tungku						Skala 1 : 2	Digambar 27 Jun '18 Diperiksa	
JURUSAN TEKNIK MESIN (DIII) POLITEKNIK NEGERI SRIWIJAYA								

Tol.: ± 0,05

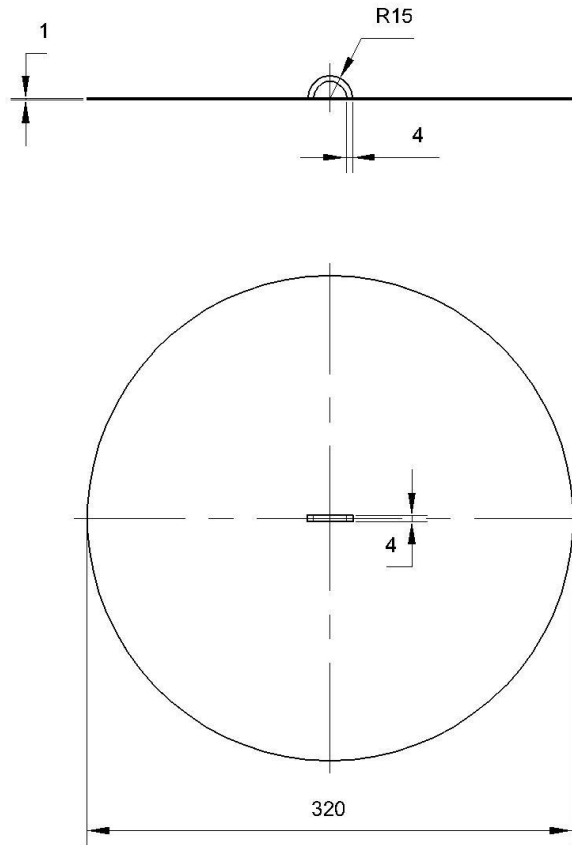

		1	Tutup Tungku	6	Plate	Ø320 x 1 mm	Dibuat			
JUMLAH			NAMA BAGIAN	NO. BAGIAN	BAHAN	UKURAN	KETERANGAN			
III	II	I	Perubahan:							
Sub Assembling Tutup Tungku						Skala 1 : 5	Digambar	27 Jun '18		
							Diperiksa			
JURUSAN TEKNIK MESIN (DIII) POLITEKNIK NEGERI SRIWIJAYA										

Tol.: ± 0,05

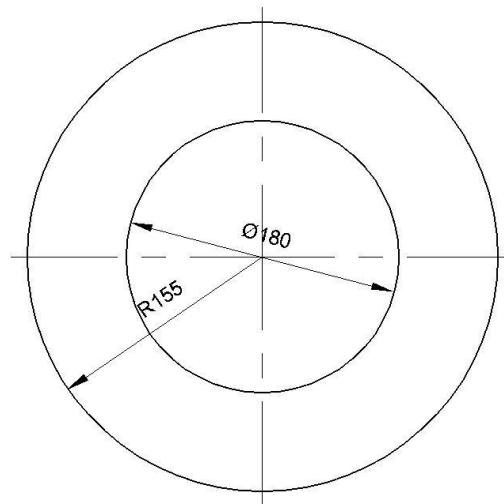

		2	Penahan Cawan	8	Plate	Ø310 x 1 mm	Dibuat
JUMLAH		NAMA BAGIAN		NO. BAGIAN	BAHAN	UKURAN	KETERANGAN
III	II	I	Perubahan:				
			Sub Assembling Tutup Tungku			Skala 1 : 2	Digambar 27 Jun '18
							Diperiksa
JURUSAN TEKNIK MESIN (DIII) POLITEKNIK NEGERI SRIWIJAYA							

Tol.: ± 0,05

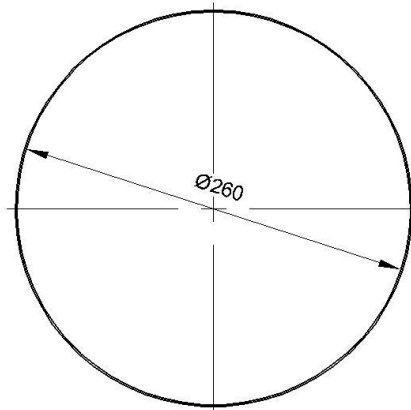
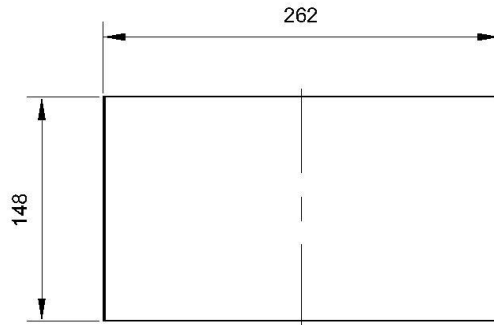

		1	Dinding Dalam	9	Plate	Ø262 x 150 mm	Dibuat			
JUMLAH			NAMA BAGIAN	NO. BAGIAN	BAHAN	UKURAN	KETERANGAN			
III	II	I	Perubahan:							
Sub Assembling Tutup Tungku						Skala 1 : 2	Digambar	27 Jun '18		
							Diperiksa			
JURUSAN TEKNIK MESIN (DIII) POLITEKNIK NEGERI SRIWIJAYA										

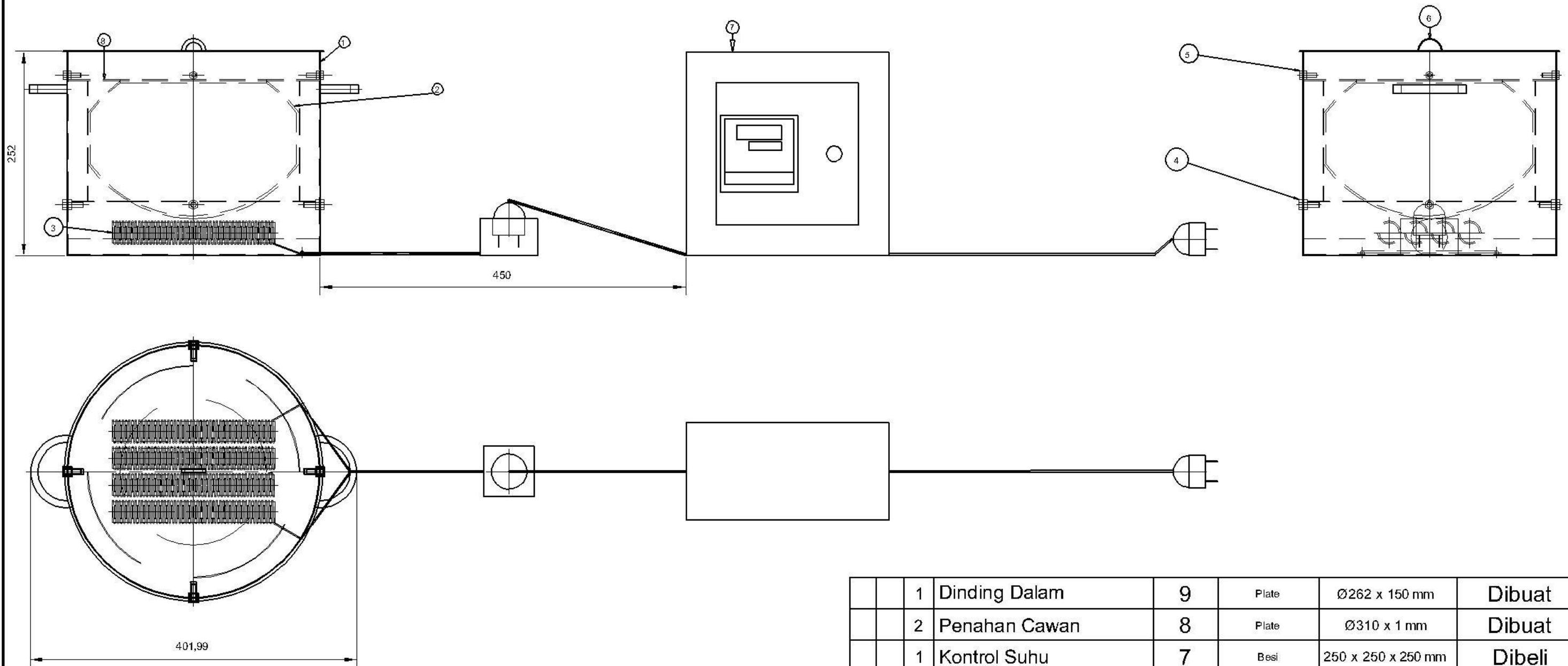

	1	Dinding Dalam	9	Plate	Ø262 x 150 mm	Dibuat
	2	Penahan Cawan	8	Plate	Ø310 x 1 mm	Dibuat
	1	Kontrol Suhu	7	Besi	250 x 250 x 250 mm	Dibeli
	1	Tutup Tungku	6	Plate	Ø320 x 1 mm	Dibuat
	4	Baut Penahan Atas	5	Besi	Ø10 x 40 mm	Dibeli
	4	Baut Penahan Bawah	4	Besi	Ø12 x 40 mm	Dibeli
	1	Elemen Pemanas	3	Tembaga	Ø160 x 5 mm	Dibeli
	1	Cawan Lebur (Tabung LPG)	2	Baja Canai Panas	Ø260 X 300 mm	Dibeli
	1	Badan Tungku	1	Plate	Ø310 X 250 mm	Dibuat
	JUMLAH	NAMA BAGIAN	NO. BAGIAN	BAHAN	UKURAN	KETERANGAN
III	II	I	Perubahan:			
			DAPUR PELEBUR ALUMINIUM DENGAN ELEMEN PEMANAS		Skala 1 : 5	Digambar 27 Jun '18 Diperiksa
			JURUSAN TEKNIK MESIN (DIII) POLITEKNIK NEGERI SRIWIJAYA			