

12	Baut M10	15	Fc-490	M10 x 1,5	Dibeli
4	Baut M16	14	Fc-490	M16 x 2,0	Dibeli
1	Bak Penampung	13	Fc360	375x220	Dibuat
1	Drum Pemipil	12	SCM10	Ø75x254	Dibuat
1	Baki Pemipil	11	Besi Nako	5x6x360	Dibeli
1	Poros Pemipil	SC30	Ø25 x 204	Dibuat	
1	Platay Pemipil	9	ST-41	100 x 2	Dibuat
1	Rumah Pemipil	8	Plat Fc360	450x220	Dibuat
2	Pillow Block Bearing	7	Besi Tuang	UCP205-16	Dibeli
1	Cover	6	Plat Fc360	450x210x180	Dibuat
1	Pulley 5"	5	Aluminium	SPZ Type 3"	Dibeli
1	V-Belt	4	Karet	A30 V Belt Type A	Dibeli
1	Pulley 3"	3	Aluminium	SPZ Type 5"	Dibeli
1	Motor Listrik	2		0,5 HP	Dibeli
1	Rangka	1	Profil L	500x420x220	Dibuat

JUMLAH	NAMA BAGIAN	NO. BAG	BAHAN	UKURAN	KETERANGAN
I	II	III	PERUBAHAN		
<b>MESIN PEMIPIL JAGUNG KERING</b>					SKALA 1 : 5
POLITEKNIK NEGERI SRIWIJAYA Jl. Sriwijaya Negara Bukit Besar Palembang Web Site : www.polri.ac.id					DISAMBAH DISPERIKUSA RONE JUNAIDI
DRNAME : TA / ASSEMBLY / 2019					TEAM

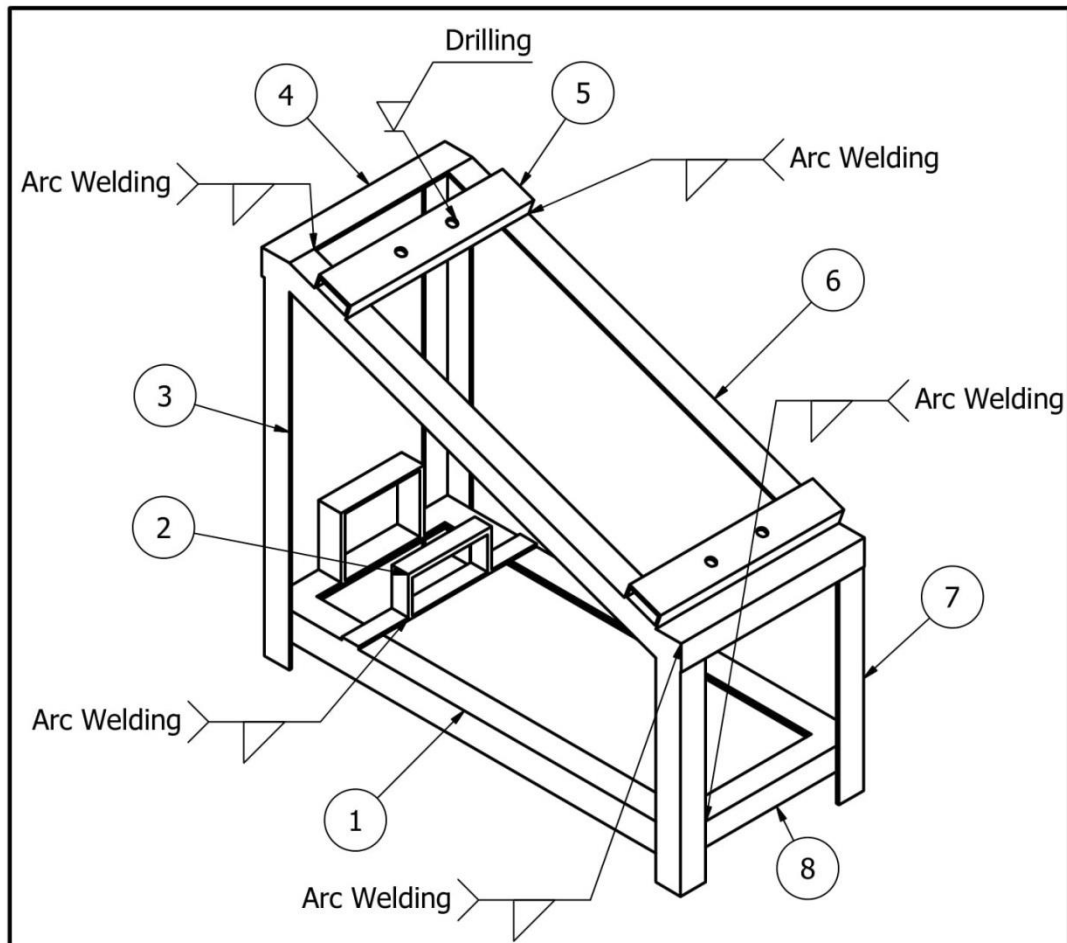

		2	Sambungan Kaki Bawah	8	Profil L	L 30 x 30 x 210	Dibuat
		2	Kaki Kanan	7	Profil L	L 30 x 30 x 260	Dibuat
		2	Tengah Atas	6	Profil L	L 30 x 30 x 480	Dibuat
		2	Dudukan Bearing	5	Besi Hollow	40 x 20 x 220	Dibuat
		2	Sambungan Kaki Atas	4	Profil L	L 30 x 30 x 220	Dibuat
		2	Kaki Kiri	3	Profil L	L 30 x 30 x 420	Dibuat
		2	Dudukan Motor Listrik	2	Profil U	80 x 20 x 220	Dibuat
		2	Tengah Bawah	1	Profil L	L 30 x 30 x 500	Dibuat
		JUMLAH	NAMA BAGIAN	NO.BAG.	BAHAN	UKURAN	KETERANGAN

I	II	III	PERUBAHAN					
			<b>Assembly Rangka</b>			SKALA	DIGAMBAR	TEAM
						1 : 5	DIPERIKSA	ROMI JUNAIDI
			POLITEKNIK NEGERI SRIWIJAYA Jl. Srijaya Negara Bukit Besar Palembang Web Site : www.polsri.ac.id			DRAME : TA / Assembly Rangka / 2019		



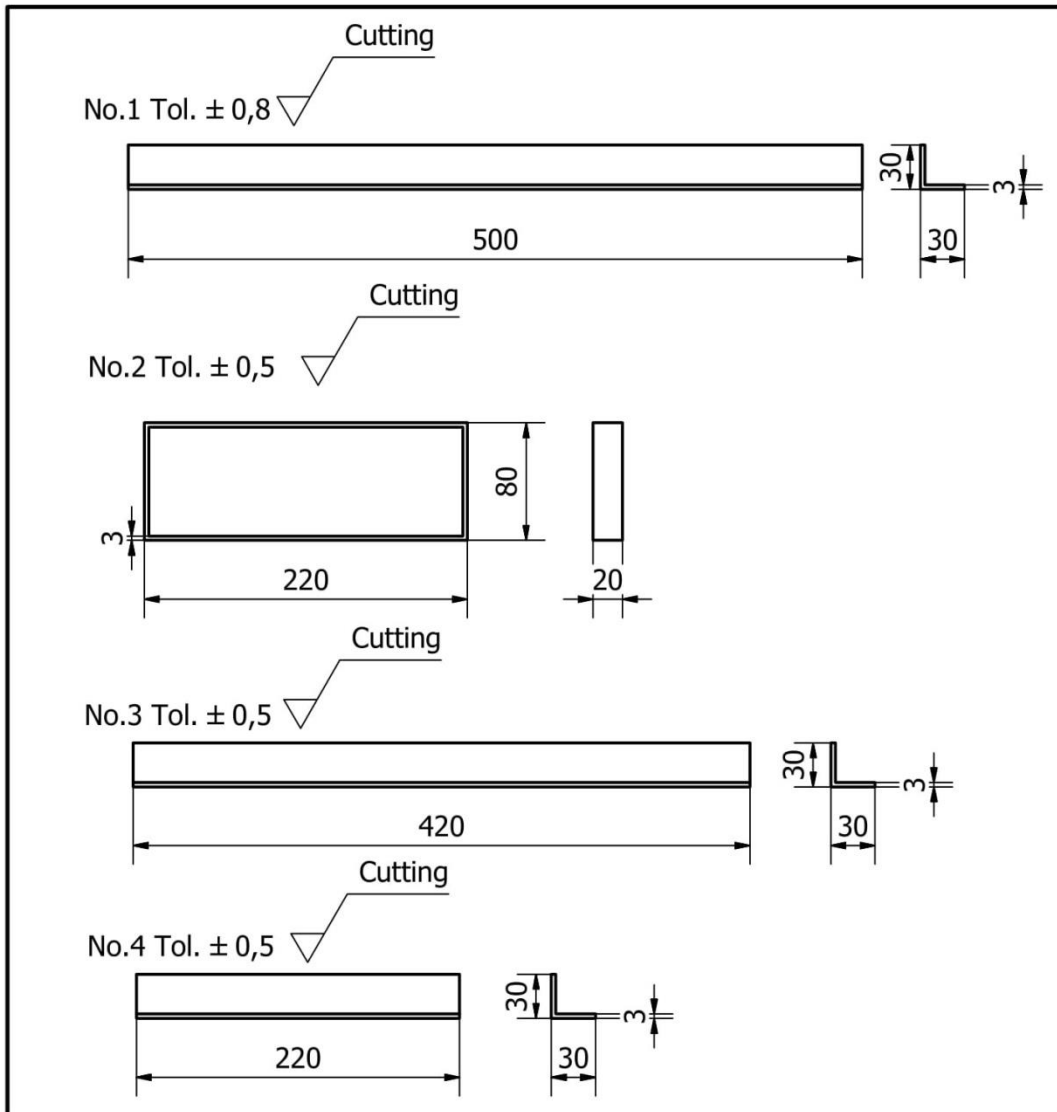

		2	Sambungan Kaki Atas	4	Profil L	L 30 x 30 x 220	Dibuat	
		2	Kaki Kiri	3	Profil L	L 30 x 30 x 420	Dibuat	
		2	Dudukan Motor	2	Profil L	U 80 X 20 X 220	Dibuat	
		2	Tengah Bawah	1	Profil L	L 30 x 30 x 500	Dibuat	
		JUMLAH	NAMA BAGIAN	NO.BAG.	BAHAN	UKURAN	KETERANGAN	
I	II	III	PERUBAHAN					
<b>Bagian-bagian Rangka</b>						SKALA	TEAM	
						1 : 5	ROMI JUNAIDI	
POLITEKNIK NEGERI SRIWIJAYA Jl. Srijaya Negara Bukit Besar Palembang Web Site : www.polsri.ac.id						DRAME : TA / Bagian-bagian Rangka / 2019		

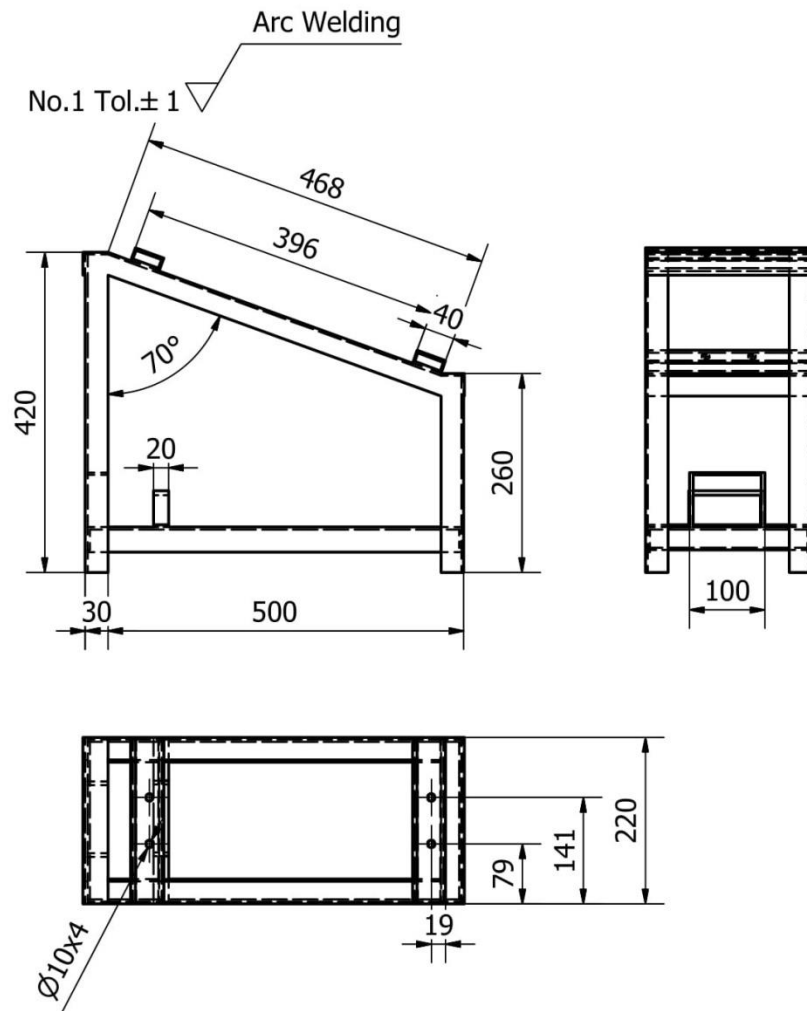

		1	Rangka	1	Profil L Fe360	500x420x260	Dibuat	
JUMLAH			NAMA BAGIAN	NO. BAG	BAHAN	UKURAN	KETERANGAN	
I	II	III	PERUBAHAN					
<b>Rangka</b>						SKALA	DIGAMBAR	TEAM
						1 : 5	DIPERIKSA	ROMI , JUNAIDI
POLITEKNIK NEGERI SRIWIJAYA Jl. Srijaya Negara Bukit Besar Palembang Web Site : www.polsri.ac.id						DRAME : TA / RANGKA / 2019		

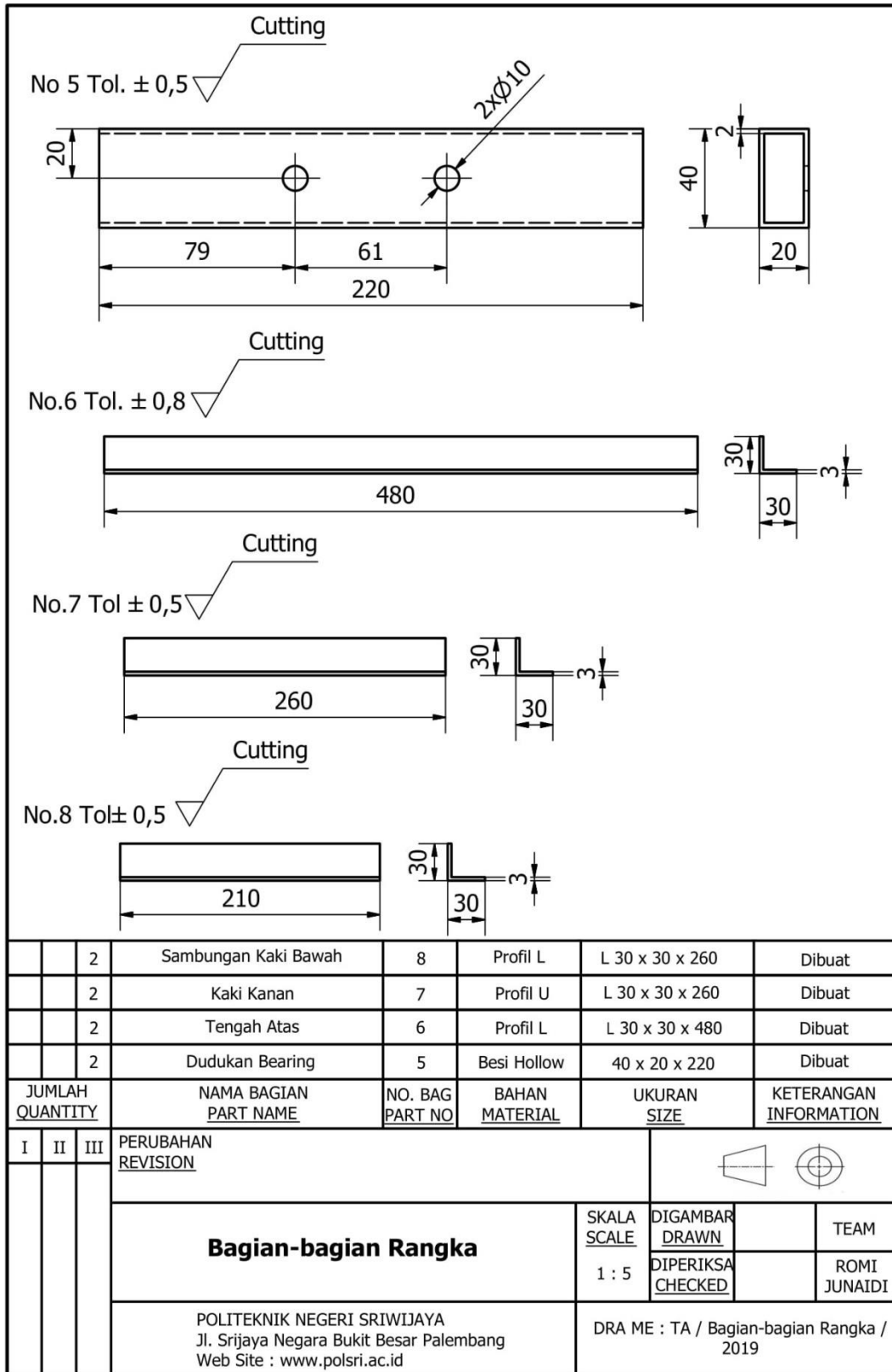

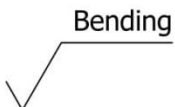
No.6 Tol.± 2 

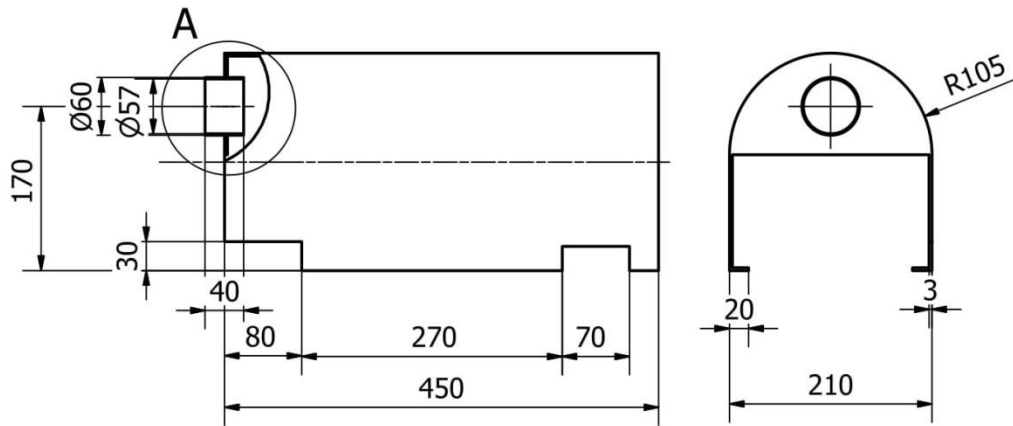

A ( 1 : 3 )

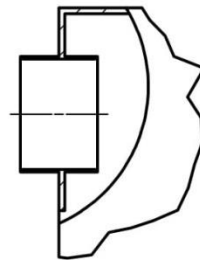

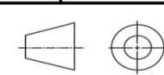
		1	Cover	6	Plat Fe360	450x210	Dibuat	
JUMLAH			NAMA BAGIAN	NO.BAG.	BAHAN	UKURAN	KETERANGAN	
I	II	III	PERUBAHAN					
<b>COVER</b>						SKALA	TEAM	
						1 : 5	ROMI JUNAIDI	
POLITEKNIK NEGERI SRIWIJAYA Jl. Srijaya Negara Bukit Besar Palembang Web Site : www.polsri.ac.id						DRAME : TA / COVER / 2019		

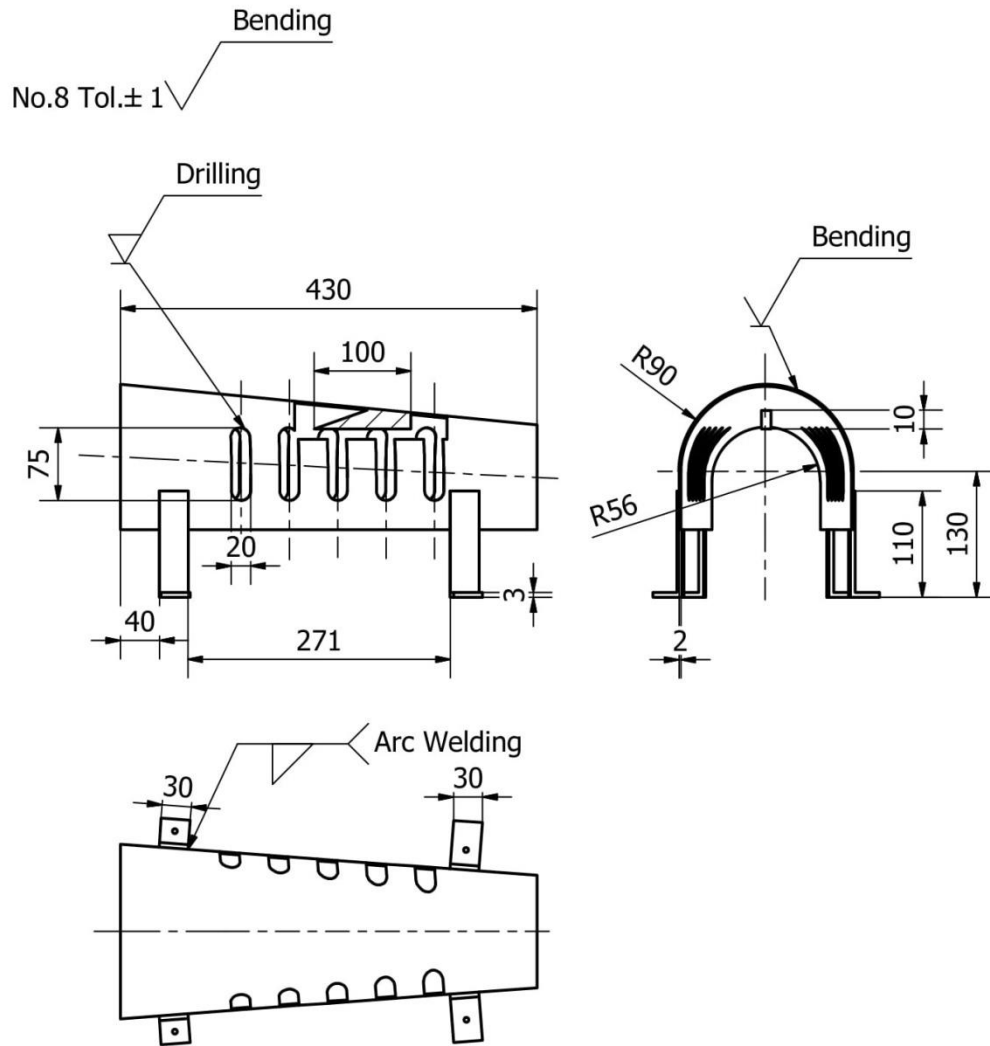

		1	Rumah Pemipil	8	Plat Fe360	430x180x150	Dibuat	
JUMLAH			NAMA BAGIAN	NO. BAG	BAHAN	UKURAN	KETERANGAN	
I	II	III	PERUBAHAN					
<b>Rumah Pemipil</b>						SKALA	DIGAMBAR	TEAM
						1 : 5	DIPERIKSA	ROMI JUNAIDI
POLITEKNIK NEGERI SRIWIJAYA Jl. Srijaya Negara Bukit Besar Palembang Web Site : www.polsri.ac.id						DRAME : TA / Rumah Pemipil / 2019		



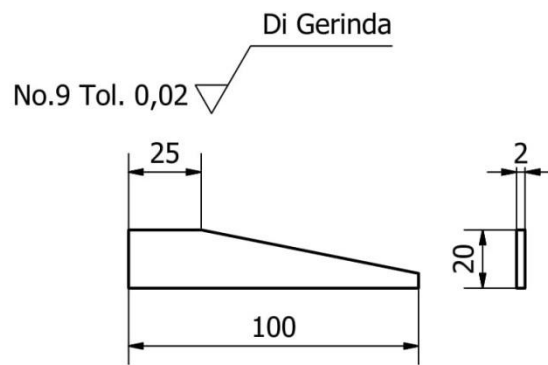
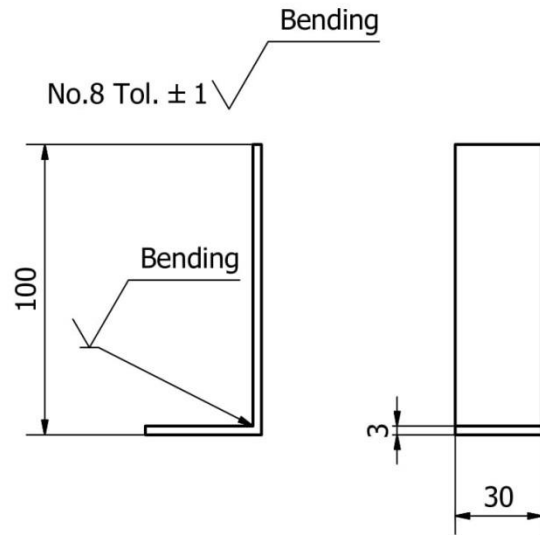

		1	Kaki Pemipil	8	Plat Fe360	100 x 30 x 3	Dibuat
		1	Pisau Pemipil	9	ST41	100 x 2	Dibuat
JUMLAH			NAMA BAGIAN	NO.BAG	BAHAN	UKURAN	KETERANGAN
I	II	III	PERUBAHAN				
<b>Pisau dan Kaki Pemipil</b>					SKALA	DIGAMBAR	TEAM
					1 : 2	DIPERIKSA	ROMI JUNAIDI
POLITEKNIK NEGERI SRIWIJAYA Jl. Srijaya Negara Bukit Besar Palembang Web Site : www.polsri.ac.id					DRAME : TA / Rumah Pemipil 02 / 2019		

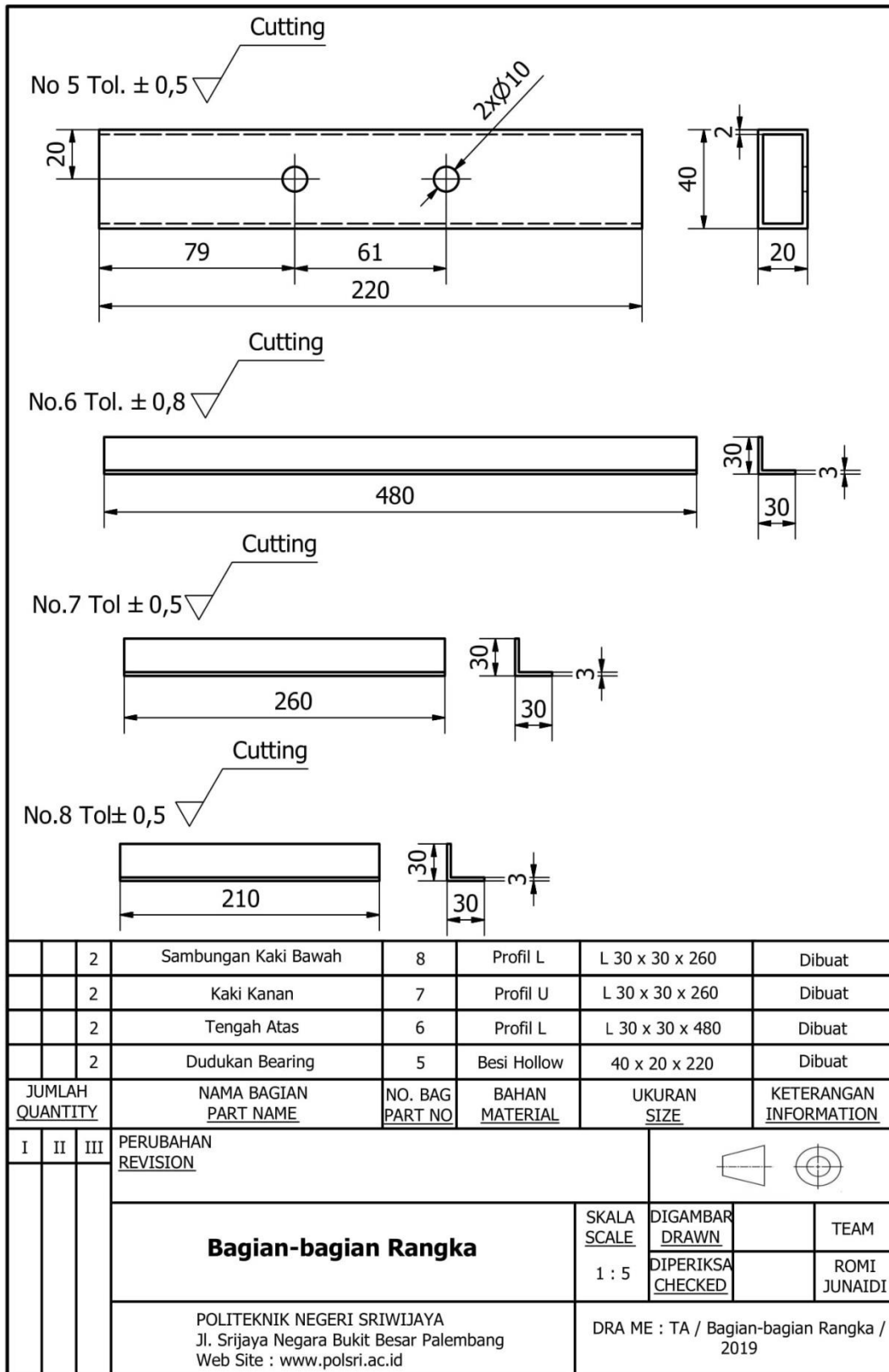

No.13 Tol.± 2  Bending

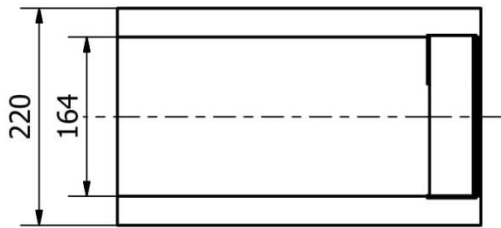
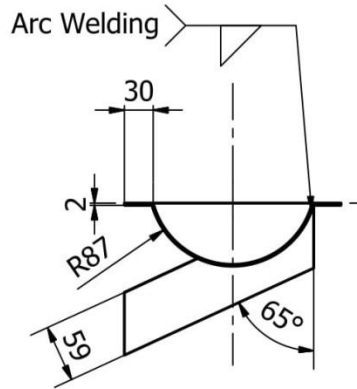
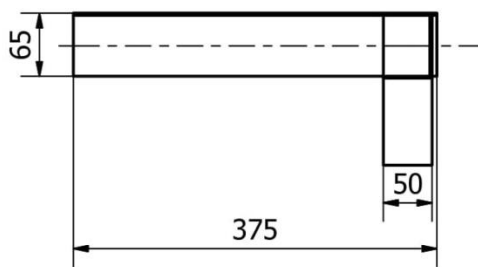

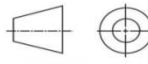
		1	Penampung	13	Plat Fe360	385x224	Dibuat	
JUMLAH			NAMA BAGIAN	NO. BAG	BAHAN	UKURAN	KETERANGAN	
I	II	III	PERUBAHAN					
<b>Penampung</b>						SKALA	TEAM	
						1 : 5	ROMI JUNAIDI	
POLITEKNIK NEGERI SRIWIJAYA Jl. Srijaya Negara Bukit Besar Palembang Web Site : www.polsri.ac.id						DRAME : TA / Penampung / 2019		