

2) POROS GAGANG 

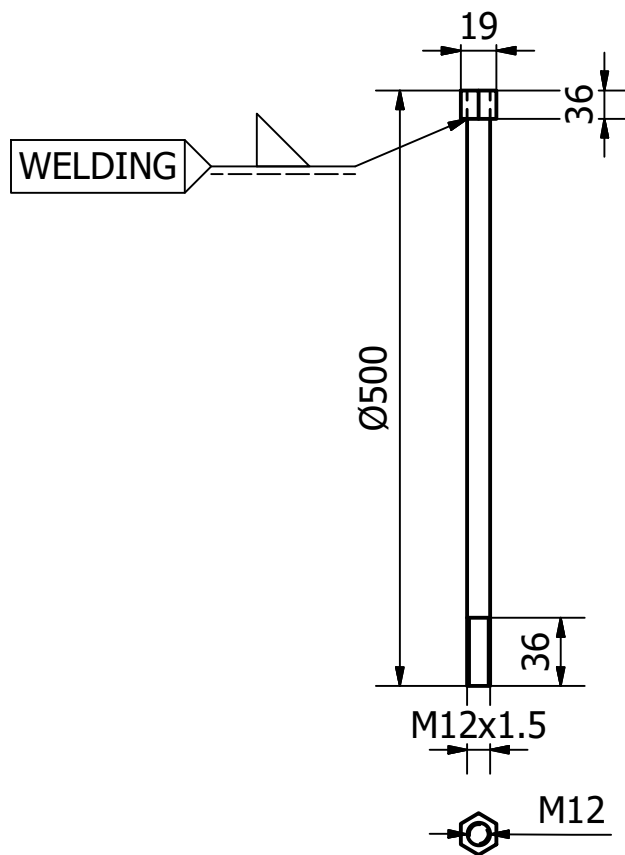

| | | | | | | | |
|--|----|-------------|--------------|--------|----------|---|---|
| | | 1 | POROS GAGANG | 2 | ST.42 | $\text{Ø}12\text{MM} \times 464\text{MM}$ | DIBUAT |
| JUMLAH | | NAMA BAGIAN | | NO.BGN | MATERIAL | UKURAN | KETERANGAN |
| III | II | I | PERUBAHAN : | | |  | |
| PERANCANGAN ALAT BANTU POTONG LINGKARAN DENGAN DIAMETER MAKSIMAL 45 CM | | | | | | SKALA 1 : 12 | DIGAMBAR DIPERIKSA QAULAM PEMBIMBING |
| POLITEKNIK NEGERI SRIWIJAYA TAHUN 2019 | | | | | | DRAME/02/PART/2019 | |